



Kitchen Appliance
COLLECTION | 2018



CONTENTS

COOKING

OVENS	9
STEAM OVENS	35
MICROWAVES	45
COFFEE MACHINES	55
WARMING AND STORAGE DRAWERS	61
RANGE COOKERS	67
HOBBS	73
EXTRACTION	103
VENTING	158
SPLASHBACKS	161

COOLING

PROFESSIONAL REFRIGERATION	170
FREESTANDING REFRIGERATION	178
INTEGRATED REFRIGERATION	180
WINE CABINETS	191

WASHING

DISHWASHERS	216
WASHING MACHINES	225
WASHER DRYER	228
TUMBLE DRYERS	230

PLINTH HEATERS	232
FOOD WASTE DISPOSAL	234
INSTALLATION DIAGRAMS	236
CAPLE CARE	268



Making functionality fashionable

Beautiful, functional and technologically advanced, Caple appliances are central to the concept of a contemporary kitchen.

From super sleek induction hobs to discretely effective cooker hoods, whisper quiet dishwashers and smart [in every sense] wine cabinets, they cater for every lifestyle.

Chef, entertainer, home maker? Whatever your passion Caple provides the inspiration to carry it off with exceptional style. Our range offers the depth and versatility to seamlessly slot into your kitchen, whatever its design or layout. Discover exciting new ways to cook, cool or wash, but above all, bring out the beating heart of your home.

COOKING

6

7

Ovens	9
Steam Ovens	35
Microwaves	45
Coffee Machines	55
Warming and Storage Drawers	61
Range Cookers	67
Hobs	73
Extraction	103
Venting	158
Splashbacks	161



Ovens

There's a Caple oven for every kind of kitchen and every type of lifestyle. Choose from our flagship Sense Premium collection, the sleek and elegant SENSE range and our exceptionally versatile Classic.



SENSE PREMIUM OVENS

Our collection of Sense Premium ovens boasts elegant design and class leading functionality, putting uncompromising control at your fingertips.

Stunning grey interiors bring style to your cooking. Sleek LED-lit touch controls and programming allow you to rise to the occasion and effortlessly set your oven to work.

THE PIZZA FUNCTION

The C2481SS reaches 350°C meaning you can cook two fresh pizzas to perfection in under three minutes.



TELESCOPIC SHELVES

Look out for models with telescopic shelves, making it easier and safer to check food as it cooks.



TOUCH CONTROL

.....

FINGERPRINT RESISTANT STAINLESS STEEL

SELF-CLEANING TECHNOLOGY

The C2481SS Pyrolytic technology works by heating the oven to 475°C, causing even hidden and baked-on grime to carbonise into a fine ash. It saves you vast amounts of elbow grease, and actually improves oven efficiency over time too.



EASY CLEAN

A clever clean function returns your oven to a fresh and spotless condition in just 60 minutes, taking advantage of special enamel with a micro-porous structure to oxidise residues at 250°C.



BOOST

The Boost function, which preheats the oven in super quick time, makes sure it reaches just the right temperature rapidly.

COOKING

IO

II

OVENS

SINGLE OVENS



With handy features like telescopic runners and soft close hinges, our built-in single ovens are big on looks and highly practical. The perfect solution when space is at a premium.

Look out for products marked with Sense Premium, Sense or Classic flags to easily identify the range.



SENSE PREMIUM ELECTRIC PYROLYTIC PIZZA SINGLE OVEN



PRODUCT CODE

sp C2481SS

DIMENSIONS

w:600mm

PERFORMANCE

e Energy Class A+

FINISH AVAILABLE

Fingerprint Resistant
Stainless Steel

FUNCTIONS

18 Functions

- Light
- Base heat
- Convection heat
- Fan heat
- Turbo convection heat
- Turbo base heat
- Eco cooking
- Grill
- Turbo grill with base heat
- Turbo grill
- Base heat plus fan heat
- Classic Pizza [350°C]
- Defrost
- Dehydrate
- Warm
- Warm+
- Sabbath
- Pyrolytic clean

OVEN FEATURES

- Cooks two fresh pizzas in 3 minutes
- 65 Litre capacity
- Rotisserie cooking
- Temperature probe
- Demo display mode
- Boost [Fast preheat]
- Full touch control
- Programmable electronic timer
- Preset recipes
- Personalised recipes
- Stainless steel, black-spot feature bar handle
- Quadruple glazed door with heat reflective glass
- Door safety lock during pyrolytic function
- Closed door grilling
- Twin speed tangential cooling fan
- Grey nickel free, easy clean enamel interior
- Twin halogen lights

ACCESSORIES

- 1 Safety-stop shelf
- 1 Grill pan with handle
- 1 Telescopic shelf
- 1 Rotisserie rack
- 1 Meat temperature probe

OPTIONAL ACCESSORIES

- Pizza stone, pizza shovel and wire tray [PIZZASET]

INSTALLATION

- Diagram [p.236]
- Rated load 3.45kW
- Fuse rating 20A

Features



PERFECT PIZZA

Our Sense Premium collection features the new C2481SS pyrolytic pizza oven. Fresh pizza cooked to perfection in under three minutes!

PIZZA DOUGH

The C2481SS utilises a 40°C cooking setting which is ideal for proving fresh pizza dough.

SLOW COOKING

Use the base heat function at 90°C to slowly cook just about every tender cut of beef, lamb, pork and veal. Sear the meat then slowly roast the joint over a longer period of time - the benefit to this over conventional roasting is more succulent and full flavoured meat.

DEHYDRATE

Dehydration is a method of extracting moisture from food at low temperatures. Food can be preserved in this way so it's a great way to use a surplus of fresh produce or just to produce healthy snacks.

You can dehydrate fruit, herbs and vegetables and even meat such as jerky.



SENSE PREMIUM ELECTRIC SIDE OPENING SINGLE OVEN



PRODUCT CODE
sp C2161SS

DIMENSIONS
w:600mm

PERFORMANCE
e Energy Class A++

FINISH AVAILABLE
Fingerprint Resistant Stainless Steel

FUNCTIONS
14 Functions

- Light
- Base heat
- Convection heat
- Fan heat
- Turbo convection heat
- Full grill
- Eco grill
- Turbo grill
- Turbo base heat

- Turbo base heat with grill
- Pizza [Fan heat with base heat max. 230°C]
- Defrost
- Top heat
- Clean

OVEN FEATURES

- 65 Litre capacity
- Temperature probe
- Demo display mode
- Boost [Fast preheat]
- Clean
- Full touch control
- Programmable electronic timer
- Auto cooking with 36 Preset recipes
- Personalised recipes
- Stainless steel, black-spot feature bar handle
- Triple glazed cool touch door with heat reflective glass
- Closed door grilling
- Twin speed tangential cooling fan

- Grey nickel free, easy clean enamel interior
- Twin dual level halogen lights

ACCESSORIES

- 1 Safety-stop shelf
- 1 Grill pan with handle
- 1 Enamelled baking tray
- 1 Meat temperature probe

OPTIONAL EXTRAS

- Oven steam set [STEAMSET]
 - Chrome wire shelf [SHELF/SOVEN]
 - Grey enamel baking tray [TRAY/SPOVEN]
- Visit caple.co.uk for full range

INSTALLATION

- Diagram [p.236]
- Rated load 3.5kW
- Fuse rating 20A

SENSE PREMIUM ELECTRIC SINGLE OVENS



C2151SS



C2150WH

PRODUCT CODE

- sp Stainless Steel C2151SS
- sp White Glass C2150WH

DIMENSIONS

w:600mm

PERFORMANCE

- e Energy Class A++ [C2151SS]
- e Energy Class A [C2150WH]

FINISH AVAILABLE

- Fingerprint Resistant Stainless Steel
- White Glass

FUNCTIONS

14 Functions

- Light
- Base heat
- Convection heat
- Fan heat
- Turbo convection heat
- Full grill
- Eco grill
- Turbo grill
- Turbo base heat
- Turbo base heat with grill
- Pizza [Fan heat with base heat max. 230°C]
- Defrost
- Top heat
- Clean

OVEN FEATURES

- 65 Litre capacity
- Temperature probe
- Demo display mode
- Boost [Fast preheat]
- Clean
- Full touch control
- Programmable electronic timer
- Auto cooking with 36 preset recipes
- Personalised recipes
- Stainless steel, black-spot feature bar handle
- Triple glazed cool touch door with heat reflective glass
- Closed door grilling
- Twin speed tangential cooling fan
- Grey nickel free, easy clean enamel interior
- Twin halogen lights

ACCESSORIES

- 1 Safety-stop shelf
- 1 Grill pan with handle
- 1 Enamelled baking tray
- 1 Meat temperature lights

OPTIONAL EXTRAS

- Oven steam set [STEAMSET]
 - Chrome wire shelf [SHELF/SOVEN]
 - Grey enamel baking tray [TRAY/SPOVEN]
- Visit caple.co.uk for full range

INSTALLATION

- Diagram [p.236]
- Rated load 3.5kW
- Fuse rating 20A

Features

LED TOUCH CONTROL

The intuitive control panel lets you swiftly access all functions, the electronic timer, minute minder and clock. You can also view the current cooking time and temperature.



AUTO SETTING

Choose from 36 preset recipes on the LCD panel. Includes food weight and temperature for optimum results. You can also create your own programmes.

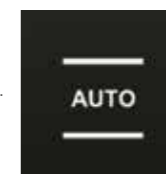

CLEAN

The nickel free, micro-porous enamel allows the oven to reach 250°C oxidising residue, making it easy to clean.



SENSE OVENS

With sultry black glass and an elegant stainless steel trim, SENSE appliances have been designed to fit together effortlessly and will turn heads in any kitchen. At the same time, smart thinking and intelligent solutions deliver the ultimate in easy functionality.

Featuring innovative touch control technology, every SENSE oven delivers outstanding results, whatever the cooking task.

MotionHeat

This function evenly distributes hot air around the oven cavity. It reaches the desired temperature rapidly & there is often no need to preheat, saving time & energy. Perfect for multi-level cooking without the transfer of flavours & you can achieve even results.

TELESCOPIC RUNNERS

As standard all SENSE ovens come with two full extension telescopic runners making it easier to check food as it cooks and reducing the risk of burning yourself on the oven interior.

PYROLYTIC OVEN

The C2401 Pyrolytic technology works by heating the oven to 475°C, causing even hidden & baked-on grime to carbonise into a fine ash. It saves you vast amounts of elbow grease, & can in-fact improve oven efficiency over time.

SOFT CLOSE

The C2105 features a clever soft-close hinge which activates when the door is inches away from the closed position preventing it from shutting abruptly.

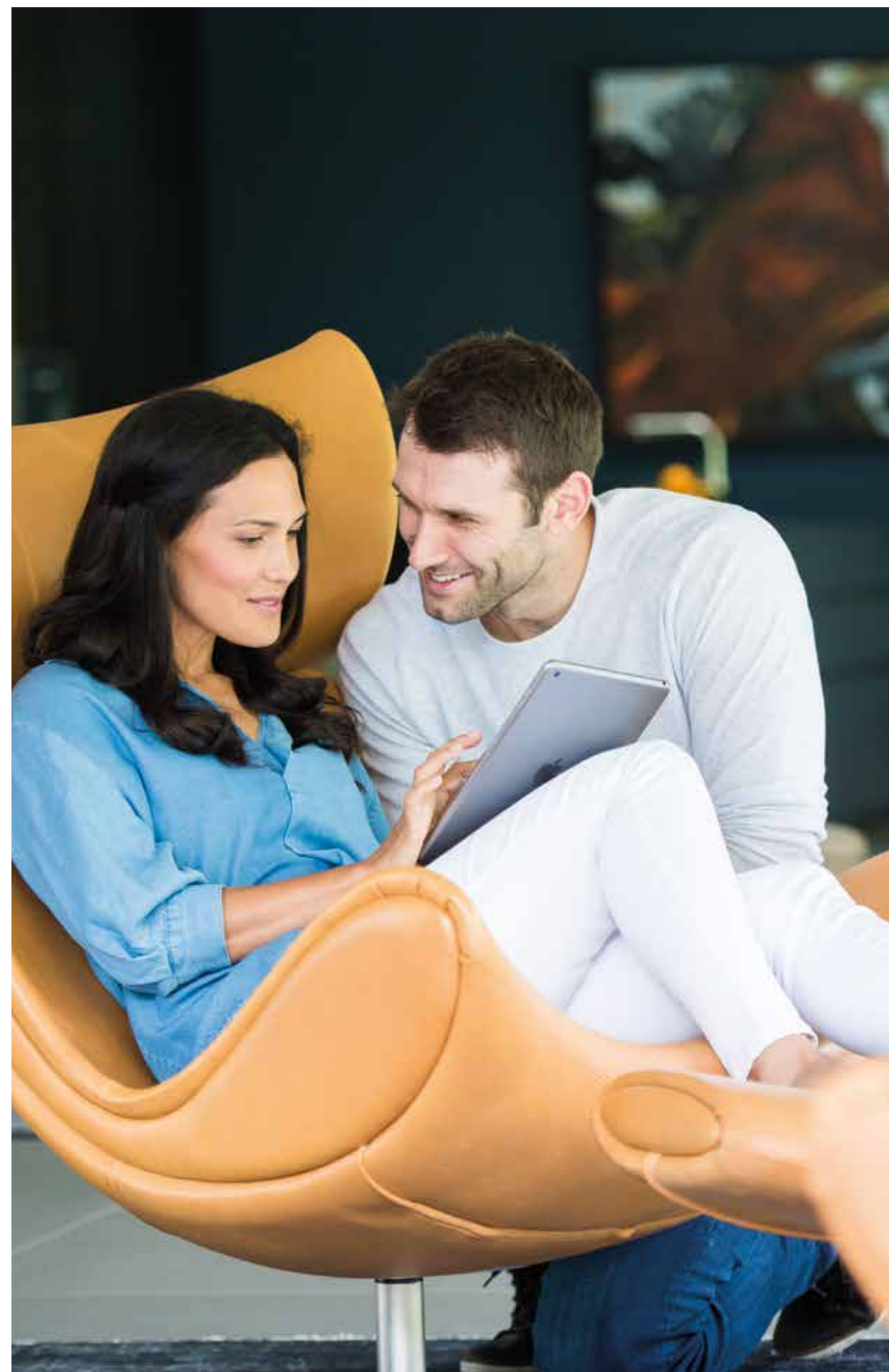



SENSE ELECTRIC 90CM SINGLE OVEN



PRODUCT CODE
S C2901

DIMENSIONS
w:900mm

PERFORMANCE
e Energy Class A

FINISH AVAILABLE
Black Glass with
Stainless Steel trim

FUNCTIONS
13 Functions

- Light
- Base heat
- Conventional heat
- Fan heat
- Fan heat and grill
- Turbo conventional heat
- Full grill
- Eco grill
- Turbo eco grill
- Turbo grill
- Turbo base heat
- Defrost
- Boost [rapid preheat]

OVEN FEATURES

- 95 Litre XL capacity
- Full touch control
- Programmable electronic timer
- Square bar handle
- White LED display
- Self-cleaning catalytic liners [back and sides]
- Easy clean enamel interior
- Two internal lights
- Closed door grilling
- Rotisserie cooking
- Easy to remove chrome shelf racks
- Triple glazed door
- Full width inner door glass
- Tangential cooling fan

ACCESSORIES

- 2 Safety-stop shelves
- 1 Grill pan with handle
- 2 sets of full extension telescopic runners
- 1 Rotisserie rack

INSTALLATION

- Diagram [p.237]
- Rated load 3.65kW
- Fuse rating 16A

SENSE ELECTRIC PYROLYTIC SINGLE OVEN



PRODUCT CODE
S C2401

DIMENSIONS
w:600mm

PERFORMANCE
e Energy Class A

FINISH AVAILABLE
Black Glass with
Stainless Steel trim

FUNCTIONS
13 Functions

- Light
- Base heat
- Conventional heat
- Fan heat
- Fan heat with grill
- Turbo conventional heat
- Full grill
- Eco grill
- Turbo grill
- Turbo base heat
- Pyrolytic self cleaning
- Defrost
- Boost [rapid preheat]

OVEN FEATURES

- 67 Litre capacity
- Full touch control
- Programmable electronic timer
- Square bar handle
- White LED display
- Pyrolytic self-cleaning
- Easy clean enamel interior
- Two internal lights
- Closed door grilling
- Easy to remove chrome shelf racks
- Quadruple glazed door
- Full width inner door glass
- Tangential cooling fan

ACCESSORIES

- 2 Safety-stop shelves
- 1 Grill pan with handle
- 2 Sets of full extension telescopic runners

OPTIONAL EXTRAS

- 1 Wire shelf [SHELF4]
- 1 Baking tray [TRAY4]
- Pair of telescopic runners [CAPRACK8]
- 1 Steam set [STEAMSET]

Visit cuple.co.uk for full range

INSTALLATION

- Diagram [p.237]
- Rated load 3.57kW
- Fuse rating 20A

Features

PYROLYTIC CLEANING

The C2401 Pyrolytic technology works by heating the oven to 475°C, causing even hidden & baked-on grime to carbonise into a fine ash. It saves you vast amounts of elbow grease, & actually improves oven efficiency over time too.

SENSE ELECTRIC SOFT CLOSE SINGLE OVEN

MotionHeat



PRODUCT CODE

S C2105

DIMENSIONS

↔ w:600mm

PERFORMANCE

e Energy Class A

FINISH AVAILABLE

■ Black Glass with Stainless Steel trim

FUNCTIONS

13 Functions

- Light
- Base heat
- Conventional heat
- Fan heat
- Fan heat with grill
- Turbo conventional heat
- Full grill
- Eco grill
- Turbo Eco grill
- Turbo grill
- Turbo base heat
- Defrost
- Boost [rapid preheat]

OVEN FEATURES

- 67 Litre capacity
- Full touch control
- Programmable electronic timer
- Square bar handle

- White LED display
- Soft-close door
- Self-cleaning catalytic liners [back and sides]
- Easy clean enamel interior
- Two internal lights
- Closed door grilling
- Rotisserie cooking
- Easy to remove chrome shelf racks
- Triple glazed door
- Full width inner door glass
- Tangential cooling fan

ACCESSORIES

- 2 Safety-stop shelves
- 1 Grill pan with handle
- 2 sets of full extension telescopic runners

OPTIONAL EXTRAS

- 1 Wire shelf [SHELF4]
- 1 Baking tray [TRAY3]
- Pair of telescopic runners [CAPRACK8]
- 1 Steam set [STEAMSET]
Visit cagle.co.uk for full range

INSTALLATION

- Diagram [p.237]
- Rated load 3.22kW
- Fuse rating 16A

Features

SOFT CLOSE

The C2105 features a soft close hinge which prevents the door from slamming shut and brings it gently into position.

SENSE ELECTRIC SINGLE OVEN

MotionHeat



PRODUCT CODE

S C2101

DIMENSIONS

↔ w:600mm

PERFORMANCE

e Energy Class A

FINISH AVAILABLE

■ Black Glass with Stainless Steel trim

FUNCTIONS

10 Functions

- Light
- Base heat
- Conventional heat
- Fan heat
- Turbo conventional heat
- Full grill
- Eco grill
- Turbo grill
- Defrost
- Boost [rapid preheat]

OVEN FEATURES

- 67 Litre capacity
- Full touch control
- Programmable electronic timer
- Square bar handle
- White LED display
- Self-cleaning catalytic liners [back and sides]

- Easy clean enamel interior
- Two internal lights
- Closed door grilling
- Easy to remove chrome shelf racks
- Double glazed door
- Full width inner door glass
- Tangential cooling fan

ACCESSORIES

- 2 Safety-stop shelves
- 1 Grill pan with handle
- 2 sets of full extension telescopic runners

OPTIONAL EXTRAS

- 1 Wire shelf [SHELF4]
- 1 Baking tray [TRAY3]
- Pair of telescopic runners [CAPRACK8]
- 1 Steam set [STEAMSET]
Visit cagle.co.uk for full range

INSTALLATION

- Diagram [p.237]
- Rated load 3.22kW
- Fuse rating 16A



SENSE ELECTRIC SINGLE OVEN

MotionHeat



PRODUCT CODE

S C2362

DIMENSIONS

↔ w:600mm

PERFORMANCE

e Energy Class A

FINISH AVAILABLE

■ Black Glass with Stainless Steel trim

FUNCTIONS

8 Functions

- Light
- Conventional heat
- Fan heat
- Full grill
- Eco grill
- Turbo grill
- Turbo base heat
- Defrost

OVEN FEATURES

- 67 Litre capacity
- Touch control programmable electronic timer
- Square bar handle

- White LED display
- Metal dial controls
- Self-cleaning catalytic liners [back and sides]
- Easy to clean enamel interior
- Two internal lights
- Closed door grilling
- Easy to remove chrome shelf racks
- Double glazed door
- Full width inner door glass
- Tangential cooling fan

ACCESSORIES

- 2 Safety-stop shelves
- 1 Grill pan with handle
- 2 sets of full extension telescopic runners

OPTIONAL EXTRAS

- 1 Wire shelf [SHELF4]
- 1 Baking tray [TRAY3]
- Pair of telescopic runners [CAPRACK8]
- 1 Steam set [STEAMSET]
Visit cagle.co.uk for full range

INSTALLATION

- Diagram [p.237]
- Rated load 3.22kW
- Fuse rating 16A

CLASSIC OVENS

Our high-performance Classic range comes with a host of standard and optional features, designed to make cooking even more satisfying.

These ovens are classically designed, as the name suggests, in stainless steel and sheer black glass. You'll find fully programmable electronic timers, cool-touch doors that are as good as their name suggests plus pyrolytic self-cleaning models. The push-pull knobs become flush with the fascia when not in use as well, for clean and smooth lines.

COOL-TOUCH DOORS

Double, triple and quadruple glazed doors that remain cool during cooking with heat-reflective glass and a tangential cooling fan.

LARGE VIEWING WINDOW WITH A LARGE CAPACITY TO MATCH

For more efficient cooking you can keep an eye on exactly what you're cooking without having to open the door and lose heat. Some single ovens also have a capacity as large as 69 litres, perfect for a hungriest of households.

FULL WIDTH GLASS DOOR

Most Caple classic single ovens feature full width removable inner glass to make cleaning your oven less of a chore.

PROGRAMMABLE ELECTRONIC TIMERS

You can preset cooking start and stop times.

SOLID METAL DIALS

For ease of use and precise control at your fingertips.





CLASSIC ELECTRIC SIDE OPENING SINGLE OVEN



PRODUCT CODE
C C2219

DIMENSIONS
w:600mm

PERFORMANCE
e Energy Class A

FINISH AVAILABLE
Black Glass with Stainless Steel

FUNCTIONS
4 Functions
- Light
- Fan heat
- Full grill
- Turbo defrost

OVEN FEATURES
- 65 Litre capacity
- Programmable electronic timer with green LED
- Stainless steel, black-spot feature bar handle
- Double glazed door with heat reflective glass

- Full width sealed inner door glass
- Reversible door
- Magnetic door closure
- Closed door grilling
- Tangential cooling fan
- Top interior light
- Smooth and flat oven sides with chrome shelf racks

ACCESSORIES
- 1 Safety-stop shelf
- 1 Grill pan with handle

OPTIONAL EXTRAS
- Catalytic side and rear liners [CAPCAT4]
- Dual position telescopic shelving racks [CAPRACK2]
- Grey enamel baking tray [TRAY/SOVEN]
Visit caple.co.uk for full range

INSTALLATION
- Diagram [p.238]
- Rated load 2.4kW
- Fuse rating 13A

CLASSIC ELECTRIC PYROLYTIC SINGLE OVEN



PRODUCT CODE
C C2238

DIMENSIONS
w:600mm

PERFORMANCE
e Energy Class A

FINISH AVAILABLE
Stainless Steel with Black Glass

FUNCTIONS
8 Functions
- Conventional heat
- Fan heat
- Eco grill
- Full grill
- Turbo grill
- Turbo conventional heat
- Defrost
- Pyrolytic self-cleaning

- OVEN FEATURES**
- 68 Litre capacity
 - Programmable electronic timer with green LED
 - Electronic dial control
 - Stainless steel, black-spot feature bar handle
 - Quadruple glazed door with heat reflective glass
 - Door safety lock during pyrolytic function
 - Closed door grilling
 - Tangential cooling fan
 - Interior light
 - Smooth and flat oven sides with chrome shelf racks

ACCESSORIES
- 1 Safety stop shelf
- 1 Grill pan with handle
- 1 Shelf for telescopic runners
- 2 Sets of telescopic runners

OPTIONAL EXTRAS
- 1 Safety-stop shelf [SHELF1]
- 1 Shelf for telescopic runners [SHELF2]
Visit caple.co.uk for full range

INSTALLATION
- Diagram [p.238]
- Rated load 2.6kW
- Fuse rating 13A

CLASSIC ELECTRIC SINGLE OVEN



PRODUCT CODE
C C2236

DIMENSIONS
w:600mm

PERFORMANCE
e Energy Class A

FINISH AVAILABLE
Stainless Steel with Black Glass

FUNCTIONS
9 Functions
- Light
- Conventional heat
- Eco grill
- Full grill
- Turbo grill
- Turbo conventional heat
- Fan heat
- Base plus fan heat
- Defrost

OVEN FEATURES
- 69 Litre capacity
- Programmable electronic timer with green LED
- Push in knobs
- Stainless steel, black-spot feature bar handle
- Double glazed door with heat reflective glass

- Full width removable inner door glass
- Closed door grilling
- Tangential cooling fan
- Interior light
- Easy clean enamel
- Smooth and flat oven sides with chrome shelf racks

ACCESSORIES
- 1 Safety-stop shelf
- 1 Grill pan with handle

OPTIONAL EXTRAS
- 1 Safety-stop shelf [SHELF1]
- 1 Baking tray [TRAY1]
- 1 Set of telescopic runners supplied with shelf [CAPRACK6]
Visit caple.co.uk for full range

INSTALLATION
- Diagram [p.238]
- Rated load 3.1kW
- Fuse rating 16A

CLASSIC ELECTRIC SINGLE OVEN



C2233



C2233BK

PRODUCT CODE

- c** Stainless Steel C2233
- c** Black Glass C2233BK

DIMENSIONS

- w:600mm

PERFORMANCE

- e** Energy Class A

FINISH AVAILABLE

- Stainless Steel with Black Glass
- Black Glass

FUNCTIONS

- 4** Functions
- Fan heat
- Grill
- Turbo grill
- Defrost

OVEN FEATURES

- 69 Litre capacity
- Programmable electronic timer with green LED
- Stainless steel, black-spot feature bar handle
- Double glazed door with heat reflective glass
- Full width removable inner door glass
- Closed door grilling
- Tangential cooling fan
- Interior light
- Easy clean enamel
- Smooth and flat oven sides with chrome shelf racks

ACCESSORIES

- 1 Safety-stop shelf
- 1 Grill pan with handle

OPTIONAL EXTRAS

- 1 Safety-stop shelf [SHELF1]
- 1 Baking tray [TRAY1]
- 1 Set of telescopic runners supplied with shelf [CAPRACK6]

Visit caple.co.uk for full range

INSTALLATION

- Diagram [p.238]
- Rated load 2kW
- Fuse rating 10A

Features



LARGE VIEWING WINDOW WITH A LARGE CAPACITY TO MATCH

For more efficient cooking you can keep an eye on exactly what's in the oven without opening the door and losing heat.

CLASSIC ELECTRIC SINGLE OVEN



PRODUCT CODE

- c** C2230

DIMENSIONS

- w:600mm

PERFORMANCE

- e** Energy Class A

FINISH AVAILABLE

- Stainless Steel with Black Glass

FUNCTIONS

- 4** Functions
- Fan heat
- Grill
- Turbo grill
- Defrost

OVEN FEATURES

- 69 Litre capacity
- Audible minute minder
- Stainless steel, black-spot feature bar handle
- Double glazed door with heat reflective glass
- Full width removable inner door glass
- Closed door grilling
- Tangential cooling fan
- Interior light
- Easy clean enamel
- Smooth and flat oven sides with chrome shelf racks

ACCESSORIES

- 1 Safety-stop shelf
- 1 Grill pan with handle and rack

OPTIONAL EXTRAS

- 1 Safety-stop shelf [SHELF1]
- 1 Baking tray [TRAY1]
- 1 Set of telescopic runners supplied with shelf [CAPRACK6]

Visit caple.co.uk for full range

INSTALLATION

- Diagram [p.238]
- Rated load 2kW
- Fuse rating 10A

CLASSIC GAS SINGLE OVEN



PRODUCT CODE

- c** C2512

DIMENSIONS

- w:600mm

PERFORMANCE

- e** Energy Class A

FINISH AVAILABLE

- Stainless Steel with Black Glass

FUNCTIONS

- 3** Functions
- Light
- Gas cooking
- Gas grill

OVEN FEATURES

- 70 Litre capacity
- Audible minute minder
- Stainless steel, black-spot feature bar handle
- Triple glazed door with heat reflective glass
- Flame safety device
- Closed door grilling
- Tangential cooling fan
- Interior light
- Easy clean enamel
- Smooth and flat oven sides with chrome shelf racks

ACCESSORIES

- 1 Safety-stop shelf
- 1 Grill pan with handle

OPTIONAL EXTRAS

- 1 Safety-stop shelf [SHELF/C2512]

Visit caple.co.uk for full range

INSTALLATION

- Diagram [p.238]
- Rated load 0.05kW
- Fuse rating 3A

DOUBLE OVENS

When mass catering is on the cards, Caple comes up trumps. Our Sense and Classic ranges offer the capacity and the functions you need to satisfy the largest appetites.

SENSE ELECTRIC DOUBLE OVEN

MotionHeat



PRODUCT CODE

S C3371

DIMENSIONS

↔ w:595mm

PERFORMANCE

e Energy Class A

FINISH AVAILABLE

■ Black Glass with
Stainless Steel trim

FUNCTIONS

4 Top Oven

- Conventional Heat
- Full Grill
- Base Heat
- Top Heat

8 Bottom Oven

- Light
- Turbo Defrost
- Fan Heat
- Conventional Heat
- Turbo Base Heat
- Eco Grill
- Full Grill
- Turbo Grill

OVEN FEATURES

Top Oven

- 40 Litre capacity [top oven]

Bottom Oven

- 61 Litre capacity [bottom oven]

GENERAL

- Black glass with stainless steel trim
- Square bar handle
- Metal dial controls
- Triple glazed doors with heat reflective glass
- Easy clean enamel interior
- Removable chrome shelf racks
- Tangential cooling fan
- White LED display
- Touch control programmable electronic timer
- Catalytic liners in both oven cavities

ACCESSORIES

- 1 Safety stop shelf in top oven
- 1 Safety stop shelf in bottom oven
- 1 Grill pan with handle in top oven
- 1 enamelled baking tray in bottom oven
- 2 Pairs of full extension telescopic runners

OPTIONAL EXTRAS

- Spare shelf [SHELF3]
 - Pair of telescopic runners [CAPRACK8]
 - Oven steamer [STEAMSET]
- Visit caple.co.uk for full range

INSTALLATION

- Diagram [p.239]
- Rated load 5.19kW
- Fuse rating 32A

CLASSIC ELECTRIC DOUBLE OVEN



PRODUCT CODE

S C3248

DIMENSIONS

w:595mm

PERFORMANCE

e Top Oven A
Bottom Oven A

FINISH AVAILABLE

Stainless Steel with Black Glass

FUNCTIONS

4 Top Oven

- Conventional heat
- Full grill
- Base heat
- Top heat

8 Bottom Oven

- Light
- Turbo defrost
- Fan heat
- Turbo grill
- Conventional heat
- Turbo base heat
- Eco grill
- Full grill

OVEN FEATURES

Top Oven

- 40 Litre capacity [top oven]

Bottom Oven

- 61 Litre capacity [bottom oven]

GENERAL

- Stainless steel, black-spot feature bar handles
- Triple glazed doors with heat reflective glass
- Easy clean enamel interior
- Removable chrome shelf racks
- Tangential cooling fan
- Green LED display
- Touch control programmable electronic timer

ACCESSORIES

- 1 Safety-stop shelf in top oven
- 1 Safety-stop shelf in bottom oven
- 1 Grill pan with handle in top oven
- 1 Enamelled baking tray in bottom oven

OPTIONAL EXTRAS

- Spare shelf [SHELF3]
- Oven steam set [STEAMSET]
- Pair of telescopic runners [CAPRACK7]

Visit cagle.co.uk for full range

INSTALLATION

- Diagram [p.239]
- Rated load 5.19kW
- Fuse rating 32A



CLASSIC ELECTRIC DOUBLE OVEN

PRODUCT CODE

C C3245

DIMENSIONS

w:595mm

PERFORMANCE

e Top Oven A
Bottom Oven A+

FINISH AVAILABLE

Stainless Steel with Black Glass

FUNCTIONS

4 Top Oven

- Conventional heat
- Full grill
- Base heat
- Top heat

4 Bottom Oven

- Light
- Turbo defrost
- Fan heat
- Turbo grill

OVEN FEATURES

Top Oven

- 40 Litre capacity [top oven]

Bottom Oven

- 61 Litre capacity [bottom oven]

- Stainless steel, black-spot feature bar handles
- Triple glazed doors with heat reflective glass
- Easy clean enamel interior
- Removable chrome shelf racks
- Tangential cooling fan
- Green LED display
- Programmable electronic timer

ACCESSORIES

- 1 Safety-stop shelf in top oven
- 1 Safety-stop shelf in bottom oven
- 1 Grill pan with handle in top oven
- 1 Enamelled baking tray in bottom oven

OPTIONAL EXTRAS

- Spare shelf [SHELF3]
- Oven steam set [STEAMSET]
- Pair of telescopic runners [CAPRACK7]

Visit cagle.co.uk for full range

INSTALLATION

- Diagram [p.239]
- Rated load 5.19kW
- Fuse rating 32A

Features

OVEN DOORS

The triple glazed doors with heat reflective glass and full width sealed inner door glass makes these oven doors perfect for those looking to entertain regularly.



LED TOUCH CONTROL

The C3248 intuitive control lets you swiftly access all functions, the electronic cooking timer, end time, minute minder and clock.



STEAMSET

Time to ditch the frying pan and try a healthier cooking experience. [Compatible for use with C3245, C3248, C4245, CR9228, CR9209, C2161SS, C2101, C2105, C2362, C2401, C3371, C2150WH and C2151SS]



See page 33 for more details.

BUILT-UNDER OVENS

Neat, versatile and with a host of clever design features, our built-under ovens fit perfectly beneath the worktop. Grill in the top oven whilst fan cooking in the bottom - the ultimate tool in multi-tasking cooking.

SENSE ELECTRIC BUILT-UNDER OVEN



PRODUCT CODE
S C4360

DIMENSIONS
w:594mm

PERFORMANCE
e Top Oven A
Bottom Oven A

FINISH AVAILABLE
Black Glass with Stainless Steel

FUNCTIONS

4 Top Oven

- Light
- Base heat
- Conventional heat
- Full grill
- 7 Bottom Oven
- Light
- Conventional heat
- Turbo conventional heat
- Fan heat
- Turbo base heat
- Eco grill
- Turbo grill

OVEN FEATURES

Top Oven

- 40 Litre capacity
- Double glazed doors with heat reflective glass

Bottom Oven

- 50 Litre capacity
- Touch control programmable electronic timer
- Triple glazed doors with heat reflective glass

GENERAL

- Stainless steel, black-spot feature bar handles
- Full width sealed inner door glass
- Push-pull knobs
- Closed door grilling
- Tangential cooling fan
- 1 interior light in each oven cavity
- White spotted easy-to-clean black enamel interior
- Smooth and flat oven sides with chrome shelf racks

ACCESSORIES

- 1 Safety-stop shelf in top oven
- 1 Safety-stop shelf in bottom oven
- 1 Grill pan with handle
- 1 Enamelled baking tray

OPTIONAL EXTRAS

- Catalytic liner set for both ovens [CAPCAT7]
 - Dual position telescopic shelving racks for bottom oven [CAPRACK2]
 - Grey enamel baking tray [TRAY/SOVEN]
 - Chrome wire shelf [SHELF/SOVEN]
- Visit caple.co.uk for full range

INSTALLATION

- Diagram [p.239]
- Rated load 3.75kW
- Fuse rating 20A

CLASSIC ELECTRIC BUILT-UNDER OVEN



PRODUCT CODE
C C4245

DIMENSIONS
w:595mm

PERFORMANCE

e Top Oven A
Bottom Oven A+

FINISH AVAILABLE

Stainless Steel with Black Glass

FUNCTIONS

4 Top Oven

- Conventional heat
- Full grill
- Base heat
- Top heat

8 Bottom Oven

- Light
- Turbo defrost
- Fan heat
- Conventional heat
- Turbo base heat
- Base heat
- Top heat
- Turbo conventional heat

OVEN FEATURES

Top Oven

- 40 Litre capacity

Bottom Oven

- 42 Litre capacity

GENERAL

- Stainless steel and black glass
- Stainless steel, blackspot feature bar handles
- Full width sealed inner door glass
- Triple glazed doors with heat reflective glass
- Easy clean enamel interior
- Removable chrome shelf racks
- Tangential cooling fan
- Green LED display
- Touch control programmable electronic timer

ACCESSORIES

- 1 Safety-stop shelf in top oven
- 1 Safety-stop shelf in bottom oven
- 1 Grill pan with handle
- 1 Enamelled baking tray

OPTIONAL EXTRAS

- Spare shelf [SHELF3]
 - Oven steam set [STEAMSET]
 - Pair of telescopic runners [CAPRACK7]
- Visit caple.co.uk for full range

INSTALLATION

- Diagram [p.239]
- Rated load 4.7kW
- Fuse rating 20A

Accessories



STEAMSET

PRODUCT CODE
STEAMSET

SUITABLE WITH

- CR9228
- CR9209

FEATURES

- Food steaming set for use in ovens
- Can be used with the following cooking functions
- Base heat
- Turbo base heat

- C3245
- C3248
- C4245
- C2101
- C2105
- C2362
- C2401

Steamset must be placed on wire racks not the telescopic runners for the following

INCLUDES

- 1 Enamel tray with glass lid
- 1 large perforated steam tray
- 1 gastro tub
- 1 perforated gastro tub
- 1 chrome stand for gastro tubs

- C3371
- C2161SS
- C2150WH
- C2151SS



Steam Ovens

Better taste and better for you.

Steam cooking is healthy, fuss-free and ensures fresh food retains its natural colours, flavours and shape. What's more, all the natural nutrients and goodness end up on the plate and not in the pan.

Oh, and it is also one of the most energy-efficient ways to cook food.

STEAM COMBINATION COOKING

Steam cooking is especially well suited to cooking foods like seafood, vegetables, pasta and rice - the sky's the limit.

Utilising the combined functions of a steam oven - fan, steam, and grill - you can be sure to beautifully capture flavour at every turn. From grilled fish such as tuna and salmon, to cooking succulent joints of meat with fan and steam injection to lock in moisture, combination cooking has never been so easy. Crab, lobster and other shellfish are done to perfection accompanied by steamed vegetables, from fresh new potatoes to crunchy carrots and broccoli. As for stodgy rice and soggy pasta, they will be a thing of the past.

TOUCH CONTROLS AND LCD DISPLAY

The intuitive control panel lets you swiftly access all functions, the programmable timer, minute minder and clock. You can also view the current cooking time and the actual temperature in the cavity.

STAINLESS STEEL INTERIOR

FINGERPRINT RESISTANT STAINLESS STEEL

DELICIOUS DESSERTS

Combining fan heat [dry heat] with steam [moisture] is the optimum environment for making the perfect light pastry, patisserie or cakes, as well as favourites such as rice pudding, or classic steamed pudding and custard

AUTO SETTING AND CUSTOMISED COOKING

On our Sense Premium models you can choose from 100 preset recipes displayed on the LCD panel. Includes food weight and temperature for optimum results. You can also create and save your own customised programmes.

ODOURLESS COOKING

There are no food odours with steam. This means you can prepare different parts of a meal together, without the flavours mingling. You can save energy too by cooking your meat and vegetables together.

LIGHT AND LARGE VIEWING WINDOW

From the display panel select the light function to check what is cooking without disturbing your food.



GASTRO TUBS

If you like to steam a variety of food at the same time then our stainless steel Gastro tubs make it easy. [optional accessory]



STEAM INJECTION

Creates a consistent temperature by heating up the water tank bringing the water to the correct temperature before injecting steam into the oven cavity.



SENSE PREMIUM BUILT-IN COMBINATION STEAM OVENS



SO210SS



SO209WH

PRODUCT CODE

sp Stainless Steel SO210SS

sp White Glass SO209WH

DIMENSIONS

h:450mm

PERFORMANCE

e Energy Class A++ [SO210SS]
Energy Class A+ [SO209WH]

FINISH AVAILABLE

Fingerprint Resistant
Stainless Steel

White Glass

FUNCTIONS

11 Functions

- Light
- Fan heat
- Turbo grill
- Grill and fan
- Grill
- Steam 100°C
- Steam 130°C
- Steam and fan heat
- Steam pulse
- Clean
- Auto

OVEN FEATURES

- 34 Litre capacity
- Touch control programmable electronic timer
- Electronic clock
- Stainless steel, black-spot feature bar handle
- 100 Preset cooking recipes
- Variable steam cooking temperature 40°C-100°C
- 2 Preset steam temperatures [cooking 100°C and reheating 130°]
- Steam cooking pause function
- Removable 1.54 Litre water tank
- Tangential cooling fan
- Interior light
- Stainless steel interior

ACCESSORIES

- 1 Perforated tray
- 1 Chrome grid
- 1 Stainless steel tray

OPTIONAL EXTRAS

- Stainless steel gastro-tub and lid [GTUB]
- Visit cagle.co.uk for full range

INSTALLATION

- Diagram [p.240]
- Rated load 3.2kW
- Fuse rating 16A
- Fan cooking 1530W
- Steam cooking 1100W
- Grill 1500W

Features

STEAM RECOVERY SYSTEM

Water is collected during the cooling process and recycled to reduce the amount used.

DECALCIFICATION

Intuitive automatic descaling system to prevent limescale build up.



SENSE BUILT-IN COMBINATION STEAM OVEN



Features

EASY CLEAN STAINLESS STEEL INTERIOR

The beautiful stainless steel interior of the SO110 means the cavity can simply be wiped clean after every use.

PRODUCT CODE

s SO110

DIMENSIONS

h:450mm

PERFORMANCE

e Energy Class A

FINISH AVAILABLE

Black Glass with
Stainless Steel trim

FUNCTIONS

10 Functions

- Light
- Defrost
- Fan heat
- Grill
- Turbo grill
- Steam
- Turbo grill and fan
- Fan heat with steam
- Descale
- Boost [rapid preheat]

OVEN FEATURES

- 36 Litre capacity
- Full Touch control
- Programmable electronic timer
- Electronic clock
- White display
- Stainless steel interior
- Chrome shelf racks with 4 positions
- Internal light
- Double glazed removeable door
- Defrost
- Descaling programme
- Steam cooking 40-100°C

ACCESSORIES

- 1 Shelf
- 1 Grill pan and handle
- 1 Steam tray

OPTIONAL EXTRAS

- 1 Descaler liquid [DESCALER]
- Visit cagle.co.uk for full range

INSTALLATION

- Diagram [p.240]
- Rated load 3.05kW
- Fuse rating 16A
- Fan cooking 1680W
- Steam cooking 1740W
- Grill 1450W

RECOMMENDED COMBINATIONS

All our compact appliances are designed to work with a matching oven. So when thinking about your kitchen design it is important to find the right combination for your needs.

SENSE PREMIUM - LINEAR



CM210SS Microwave
WMD1356 Warming Drawer

SO210SS Steam Oven
WMD1356 Warming Drawer

CM471SS Coffee Machine
WMD1356 Warming Drawer



C2161SS Oven

C2151SS Oven

C2481SS Oven

SENSE PREMIUM - QUAD



We recommend that when installing a stack or quad of products, a pair of our installation brackets [OVEN/BRACKETS2] are purchased to support the upper product ensuring a seamless fit.



CM471WH Coffee Machine
C2150WH Oven
WMD1355WH Warming Drawer

SO209WH Steam Oven
C2150WH Oven
WMD1355WH Warming Drawer

SENSE

All our SENSE appliances have been designed to fit perfectly together. So when planning your dream kitchen it is important to find the right combination and use the space effectively.



C2401 Electric single Pyrolytic oven

C2105 Electric single oven

C2101 Electric single oven

C2362 Electric single oven



SO110 Steam oven
WD140BK Warming Drawer

CM110 Combination Microwave
WD140BK Warming Drawer

CM108 Microwave
WD140BK Warming Drawer

CM465 Coffee Machine
WD140BK Warming Drawer



ROTISSERIE

The C2901 and C2105 single ovens both feature a rotisserie rack, perfect for cooking succulent roasts.

PRECISION CONTROL AT YOUR FINGERTIPS

Most of the SENSE range features fully-programmable touch controls for precise and accurate cooking temperatures and times. Although, if you prefer the tactile feel of fixed dials, opt for the C2362 with solid metal controls.

CLASSIC - STACKED



CM123 Microwave
C2233 Oven

CM126 Microwave
C2236 Oven



CM123BK Microwave
C2233BK Oven

COOKING THE WAY YOU WANT

Our oven range features the following functions, to make cooking as easy as pie.



PIZZA COOKING

Fan and bottom elements

- Fresh pizza cooked in under three minutes
- Cooking consistently through to the middle

PERFECT FOR

Pizza



CONVENTIONAL HEAT/ CONVENTIONAL ECO HEAT

Top and bottom elements

- Cooking consistently through to the middle
- Best results, use one shelf only

PERFECT FOR

Baking



FULL GRILL

Full width grill

- Even and consistent grilling

PERFECT FOR

Large pieces of steak or fish



TOP HEAT

Top element only

- Gentle heat to brown the top of a dish

PERFECT FOR

Pasta or potato dishes



ECO GRILL

Half width grill

- Energy saving inner grill section only

PERFECT FOR

Small portions of food, such as bacon or toast



BASE HEAT

Bottom element only

- Re-heating cooked food or for keeping food warm

PERFECT FOR

All food types



TURBO CONVENTIONAL HEAT

Fan assisted top and bottom elements

- Fast and even heat distribution
- Ideal for cooking more than one food type without transferring smells or tastes

PERFECT FOR

Light and delicate baking, such as pastry or bread



FAN HEAT/FAN HEAT PLUS

Fan element/fan, top and bottom elements

- Fast and highly efficient
- Fan Heat Plus uses the top and bottom elements as well, to deliver the right temperature even faster

PERFECT FOR

Juicy roasts, no pre-heat required – crisp the outside and keep the inside soft



ROTISSERIE/CONVENTIONAL HEAT/ROTISSERIE GRILL

- Turns meat automatically as it cooks, so that it bastes itself

PERFECT FOR

Succulent roasting and even browning



TOP PLUS FAN HEAT

Fan assisted top element

- Heat from both rear and upper elements

PERFECT FOR

Finishing off a cooked dish, or melt a cheese topping without the worry of overcooking



TURBO BASE HEAT

Fan assisted bottom element

- Designed for delicate and slow cooking

PERFECT FOR

Casseroles or stews



BASE PLUS FAN HEAT

Fan element and bottom element

- Circulated heat from two directions

PERFECT FOR

Crispy pizza bases, or for finishing pastry bases



TURBO GRILL/ TURBO ECO GRILL

Fan assisted full or half grill

- Quick browning

PERFECT FOR

Cooking meat whilst keeping all the juices



TURBO DEFROST

Fan only no elements

- No heat, fan only
- Uses fan power at room temperature to cut defrosting time in half

PERFECT FOR

Frozen desserts



GRILL PLUS BASE HEAT

Full grill and bottom element

- Maintains consistent temp

PERFECT FOR

Giving a nice crisp outside – great for pies



MotionHeat

Fan heat

- Even heat distribution
- No flavour transfers across dishes

PERFECT FOR

Multi-level cooking

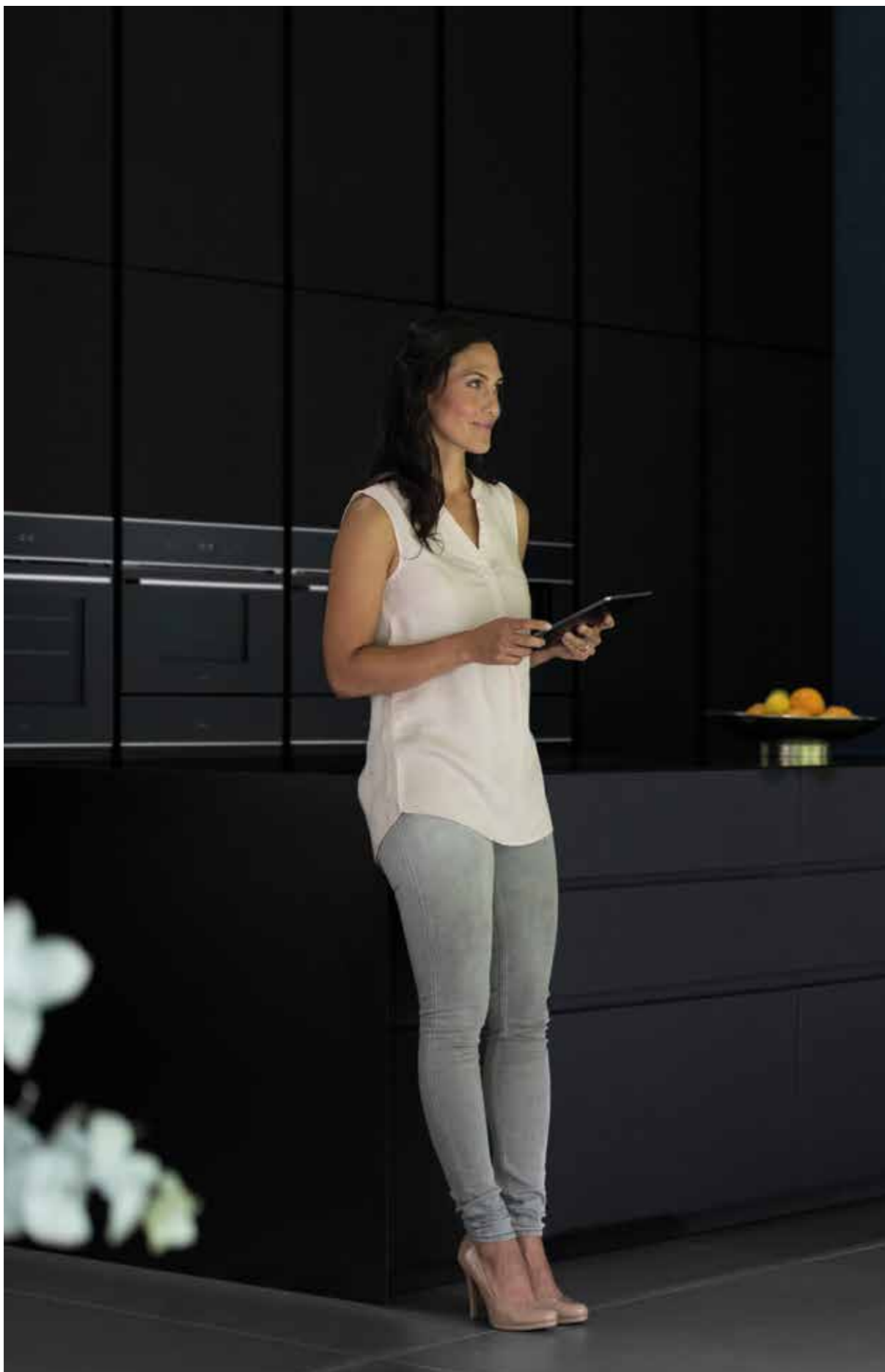

Microwaves

Caple microwaves are packed with clever technology, and perfect for making quick and easy snacks as well as serious cooking. A must-have for a busy lifestyle.

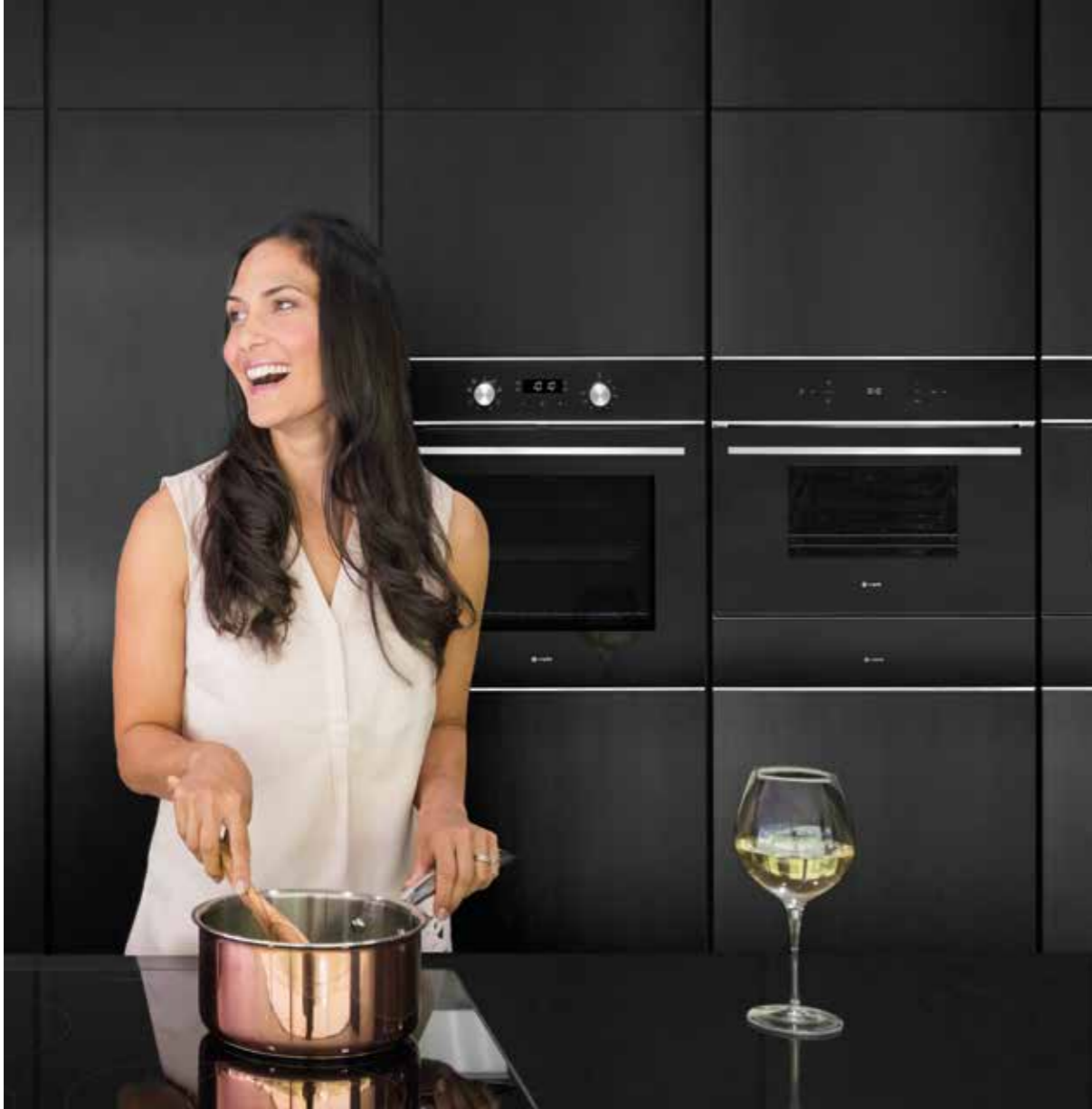

DELICIOUS MEALS IN MINUTES

Minimalist design to complement any kitchen, yet big on handy features.

Depending on your cooking requirements, you can choose a microwave for its traditional uses such as warming up leftovers or defrosting food quickly. Alternatively, why not opt for a combination microwave? As well as cooking meals quickly, you can also use it as a normal oven and grill providing extra space when you are entertaining.

TURNTABLE FREE DESIGN

Exclusive to our Sense range, these exquisitely designed microwaves look the part. Both models have 40L capacity, removable dishwasher friendly glass base and a turntable free design. This means you can fit large dishes into the 40 Litre cavity.



SENSE PREMIUM MICROWAVES

Good looks and advanced functionality makes this the perfect choice for a busy lifestyle, instinctive and powerful, it puts effortless cooking at your fingertips.



SENSE MICROWAVES

If you are in need of a traditional microwave to heat up your leftovers, the CM108 is the perfect choice. Or, if you're feeling more adventurous in the kitchen, try the CM110 combination microwave with a range of cooking options to enjoy.



CLASSIC MICROWAVES

Our CM126 model combines a microwave, grill and powerful 2500W convection oven for incredible all-round functionality.



SENSE PREMIUM BUILT-IN COMBINATION MICROWAVES



CM210SS



CM209WH

PRODUCT CODE

sp Stainless Steel CM210SS

sp White Glass CM209WH

DIMENSIONS

h:450mm

FINISH AVAILABLE

Fingerprint Resistant
Stainless Steel

White Glass

FUNCTIONS

11 Functions

- Light
- Fan heat
- Grill and fan heat
- Full grill
- Turbo grill
- Timed defrost
- Defrost by weight
- Microwave
- Microwave and grill
- Microwave and fan
- Auto settings

FEATURES

- 34 Litre capacity
- Touch control programmable electronic timer
- Electronic clock
- 6 Microwave power levels
- Thermostatic grill
- 60 Preset cooking recipes that can be customized
- Keep warm function [if door remains closed after cooking]
- Express microwave programme
- Audible timer
- Interior halogen light

DESIGN

- Stainless steel, black-spot feature bar handle
- Stainless steel interior

ACCESSORIES

- 320mm diameter glass turntable
- 1 Round chrome shelf
- 1 Chrome grid
- 1 Stainless steel tray

INSTALLATION

- Diagram [p.240]
- Rated load 3.2kW
- Fuse rating 16A
- Fan cooking 1500W
- Microwave cooking 900W
- Grill 1500W

SENSE BUILT-IN COMBINATION MICROWAVE



PRODUCT CODE

s CM110

DIMENSIONS

h:450mm

FINISH AVAILABLE

Black Glass with
Stainless Steel Trim

FUNCTIONS

- 10** Functions
- Light
 - Microwave [10 power levels]
 - Auto Defrost
 - Turbo Grill
 - Fan heat
 - Turbo conventional
 - Microwave and fan heat
 - Microwave and turbo grill
 - Microwave and conventional heat
 - Auto cooking

FEATURES

- 40 Litre capacity
- Full touch control
- Programmable electronic timer
- Electronic clock
- White display
- Stainless steel interior
- Turntable free design
- Chrome shelf rack with 3 positions
- Internal light

- Double glazed removable door
- [Microwave] 10 power levels
- Child safety lock
- 8 Auto cooking programmes
- Auto-defrost

AUTO COOKING PROGRAMMES

- Milk
- Soup
- Vegetables
- Noodles
- Bread
- Fish
- Meat
- Chicken

DESIGN

- Square bar handle
- Stainless steel interior
- White LED display

ACCESSORIES

- 1 Shelf
- 1 Baking tray
- 1 Glass base plate

INSTALLATION

- Diagram [p.240]
- Rated load 2.55kW
- Fuse rating 13A
- Microwave cooking 1000W
- Grill 1000W

SENSE BUILT-IN MICROWAVE



PRODUCT CODE

s CM108

DIMENSIONS

h:450mm

FINISH AVAILABLE

Black Glass with
Stainless Steel Trim

FUNCTIONS

- 4** Functions
- Light
 - Microwave [10 power levels]
 - Auto defrost
 - Auto cooking

FEATURES

- 40 Litre capacity
- Full Touch control
- Programmable electronic timer
- Electronic clock
- White display
- Stainless steel interior
- Turntable free design
- Internal light
- Double glazed removable door
- 10 power levels
- Child safety lock
- Auto-defrost
- 8 Auto cooking programmes

AUTO COOKING PROGRAMMES

- Milk
- Soup
- Vegetables
- Noodles
- Bread
- Fish
- Meat
- Chicken

DESIGN

- Square bar handle
- Stainless steel interior
- White LED display

ACCESSORIES

- 1 Glass base plate

INSTALLATION

- Diagram [p.240]
- Rated load 1.5kW
- Fuse rating 10A
- Microwave cooking 1000W

Features

GREAT RESULTS

Achieve great results by combining this model with a fan or grill, using the fan or grill together, or just regular convection cooking. Everything you need, in a microwave.



CONVECTION COOKING

Bringing together a ring element and a fan to provide evenly cooked and browned results. It's quicker than conventional cooking and can be combined with the microwave to reduce cooking time even more, the grill for perfect browning – or both the microwave and grill together.

TURBO GRILL

The fan cooking system and grill deliver perfect results in all kinds of meals. It even locks in meat juices for better flavour.



CLASSIC BUILT-IN MICROWAVE AND GRILL



PRODUCT CODE
C CM119

DIMENSIONS
h:388mm
[inc. built-in frame]

FINISH AVAILABLE
Stainless Steel

FEATURES

- 25 Litre capacity
- Auto cook menu
- Auto defrost
- Digital controls
- Defrost by time and weight
- Speed cooking
- Multi-stage cooking
- 5 microwave power levels
- Child safety lock
- Minute timer [up to 95mins]
- LCD display

DESIGN

- Stainless steel front/cavity
- Mark resistant finish

INSTALLATION

- Diagram [p.241]
- Rated load 1.45kW
- Fuse rating 13A
- Microwave cooking 900W
- Grill 1000W

CLASSIC BUILT-IN COMBINATION MICROWAVE



PRODUCT CODE
C CM140

DIMENSIONS
h:450mm

FINISH AVAILABLE
Black Glass

FUNCTIONS

11 Functions

- Fan heat
- Grill
- Turbo grill
- Defrost by weight
- Fan heat with base heat
- Microwave
- Microwave and grill
- Microwave and turbo grill
- Microwave and fan heat
- Microwave and fan heat with base heat
- Auto settings

FEATURES

- 36 Litre capacity
- Auto cook menu
- Touch control
- 5 microwave power levels
- Combination microwave, convection and grill cooking
- Fast preheat [7mins to 230°C]

- Auto defrost
- Speed cooking
- Memory function
- Child safety lock
- Minute timer [up to 5 hours]
- End of cooking signal
- Easy clean enamel cavity
- Green LED display
- Tangential cooling fan

DESIGN

- Stainless steel, black-spot feature bar handle
- Blue enamel interior

ACCESSORIES

- 315mm diameter turntable
- Small grill rack
- Tall grill rack

OPTIONAL EXTRAS

- 1 Glass tray and chrome wire rack [TRAY2]

Visit cagle.co.uk for full range

INSTALLATION

- Diagram [p.240]
- Rated load 3.3kW
- Fuse rating 15A
- Convection cooking 1750W
- Microwave cooking 900W
- Grill 1200W

Optional extras





CLASSIC BUILT-IN COMBINATION MICROWAVE



PRODUCT CODE
C CM126

DIMENSIONS
 h:460mm
 [inc. built-in frame]

FINISH AVAILABLE
 Stainless Steel

FEATURES

- 25 Litre capacity
- Auto cook menu
- Auto defrost
- Speed cooking
- Multi-stage cooking
- Child safety lock
- Minute timer [up to 95mins]
- End of cooking signal
- LED display
- Push door
- Green LED display

DESIGN

- Stainless steel front and cavity
- Mark resistant finish

INSTALLATION

- Diagram [p.241]
- Rated load 2.5kW
- Fuse rating 13A
- Microwave cooking 900W
- Grill 1000W
- Convection cooking 2500W

CLASSIC BUILT-IN MICROWAVE AND GRILL



CM123



PRODUCT CODE

- C** CM123
- C** CM123BK

DIMENSIONS

 h:460mm
 [inc. built-in frame]

FINISH AVAILABLE

-  Fingerprint Resistant Stainless Steel
-  Black Glass

FEATURES

- 25 Litre capacity
- Auto cook menu
- Auto defrost
- Speed cooking
- Multi-stage cooking
- Child safety lock
- Minute timer [up to 95mins]
- End of cooking signal
- LED display
- Push door
- Green LED display

DESIGN

- Stainless steel front/cavity
- Mark resistant finish

INSTALLATION

- Diagram [p.241]
- Rated load 1.45kW
- Fuse rating 13A
- Microwave cooking 900W
- Grill 1000W



CM123BK

CLASSIC BUILT-IN WALL UNIT MICROWAVE AND GRILL



PRODUCT CODE

- C** CM120

DIMENSIONS

 h:382mm
 [inc. built-in frame]

FINISH AVAILABLE

-  Stainless Steel

FEATURES

- For building into a 300mm deep wall cabinet
- 17 Litre capacity
- Auto cook menu
- Auto defrost
- Speed cooking
- Multi-stage cooking

- Child safety lock
- Minute timer [up to 95mins]
- End of cooking signal
- LED display
- Push door
- Green LED display

DESIGN

- Stainless steel front and cavity
- Mark resistant finish

INSTALLATION

- Diagram [p.241]
- Rated load 1.05kW
- Fuse rating 13A
- Microwave power 700W
- Grill power 1000W



Coffee Machines

Combining the subtle art of the barista with the very latest in coffee machine technology. Caple gives you perfect coffee at the touch of a button.



THE SECRET TO GREAT COFFEE

Fantastic coffee depends on many factors. The beans you use, the way they're ground, even what temperature it is and how it is frothed. Plus, of course, finding a coffee machine that's really up to the job.



MAKING A PERFECT ESPRESSO

What you're aiming for is a pour that starts out darkly coloured then turns into shades of caramel moving slowly, like honey. Caple coffee machines makes it effortless every time.



BARISTA STYLE COFFEE

If you like milk with your coffee, you'll also need to polish up your frothing skills. The texture depends on how the air enters the milk as you steam. You need a smooth, consistent texture where the foam and milk intertwine.

Look out for blobs of froth on top, and don't boil it. If the jug's base is too hot to touch, it means the milk's probably reached the right temperature.

For hassle free barista style lattes, cappucinos and flat whites at the touch of a button opt for the CM465.



CHOOSING THE RIGHT COFFEE

Coffee beans vary in their size, shape, colour and flavour depending on the region and conditions in which they were grown. The range of unique flavours and aromas between regions is as expansive as the variety of wine available from different vineyards. It is worth experimenting with different varieties to discover a bean perfect for your palate.

Team that with one of our outstanding coffee machines and you'll have the perfect coffee every time.



SENSE PREMIUM BUILT-IN COFFEE MACHINES



CM471SS



CM471WH

PRODUCT CODE

sp Stainless Steel and Black Glass
CM471SS

sp White Glass
CM471WH

DIMENSIONS

h:450mm

FINISH AVAILABLE

 Fingerprint Resistant
Stainless Steel

 White Glass

FEATURES

- Fully automatic
- Touch control
- Settings can be adjusted for making various hot drinks such as short espresso, long espresso, normal coffee, long coffee, warm milk, warm water or cappuccino
- Coffee bean grinder
- Coffee grinder adjustment to modify how fine the coffee beans are ground

- Coffee grind time adjustment to modify how long the coffee beans are ground for
- Drink volume adjustment to modify the amount of coffee dispensed
- Steam nozzle to heat and froth milk
- Coffee strength control
- 2.5 Litre water tank
- Drip tray
- Used coffee ground bin
- Stand-by energy saving
- Cleaning warning
- Water filter
- White LED lighting

OPTIONAL EXTRAS

- 6 replacement water filters [PURITI6]
- Visit cagle.co.uk for full range

INSTALLATION

- Diagram [p.241]
- Rated load 2kW
- Fuse rating 13A



SENSE BUILT-IN COFFEE MACHINES



PRODUCT CODE

S CM465

DIMENSIONS

h:450mm

FINISH AVAILABLE

 Black Glass with
Stainless Steel Trim

FEATURES

- Fully automatic
- Full touch control with white LCD display
- Settings can be adjusted for making various hot drinks such as short espresso, long espresso, normal coffee, long coffee, warm milk, warm water or cappuccino [Milk/coffee mix can be customised]
- Coffee bean grinder
- Coffee grinder adjustment to modify how fine the coffee beans are ground [13 settings]
- Uses fresh coffee beans or pre-ground coffee
- 5 Drink volume adjustments to modify the amount of coffee dispensed [Espresso, small, medium, large, mug]. Each size can be adjusted to fit your favourite cup.
- 30 Auto programmes
- Programme machine to switch-on and warm up at set time

- Makes 2 cups at a time
- Milk jug
- Steam nozzle to heat and froth milk
- Hot water function
- 3 temperature settings
- 5 Coffee strength settings [Extra-strong, strong, medium, light, extra-light]
- 1.8 Litre water tank
- 200g coffee bean capacity
- 15 bar pressure
- Drip tray, to collect spillages
- Used coffee ground bin
- Stand-by energy saving
- Water hardness setting
- Cleaning warning
- Descale programme

ACCESSORIES

- Coffee Spoon
- Descaling agent bottle
- Milk jug
- Hot water nozzle

OPTIONAL EXTRAS

- 1 Liquid descaler [DESCALER]
- Visit cagle.co.uk for full range

INSTALLATION

- Diagram [p.241]
- Rated load 1.35kW
- Fuse rating 10A

Features

LED TOUCH CONTROL

Sleek touch controls allow you to choose the type of coffee instantly – one or two cups, espresso or white, decaffeinated, long coffee, hot water or steam.



DISPENSING NOZZLES

Filter options are provided to match the amount of coffee in use. The amount of water dispensed can be adjusted too, depending on the size of cup.



Features

CAPPUCCINO, JUST THE WAY YOU LIKE IT

Using the milk dispenser you can make your perfect flat white, latte or cappuccino.

For ease of use the coffee machine is set to deliver a standard cappuccino, although if you prefer more or less coffee you can adjust either to suit your preference.

COFFEE FOR TWO

Save time by making two cups of coffee simultaneously.

COMPLETE CONTROL

Produce your ideal beverage with ease by adjusting the settings to your preference. You can control everything from the size and strength to the fineness of your coffee grind. Perfection every time.



Warming & Storage Drawers

There's nothing more disappointing than a hot meal served on a cool plate. Caple's warming drawers keep tableware at just the right temperature for when the food is ready to be served.

Why not add a storage drawer too? It's a convenient and stylish way to organise your coffee and wine accessories.

SENSE PREMIUM WARMING DRAWERS



WMD1356



WMD1355WH

PRODUCT CODE

sp Stainless Steel
WMD1356

sp White Glass
WMD1355WH

DIMENSIONS

h:131mm

FINISH AVAILABLE

Fingerprint Resistant
Stainless Steel

White Glass

FEATURES

- Fan heating
- Push/pull opening
- Dishes for a meal for 6 people take approx 2-4mins to heat up to 70°C
- Extremely rigid to support the weight of an appliance on top
- Maximum capacity 10kg or 6 dinner plates, 6 soup plates, 3 serving bowls and 2 platters
- 400W Heating element with tangential fan
- 30-70°C adjustable thermostat
- Smooth slide soft-close drawer runners and attractive black interior glass base

INSTALLATION

- Diagram [p.242]
- Rated load 0.4kW
- Fuse rating 3A

SENSE WARMING DRAWER



PRODUCT CODE

s WD140BK

DIMENSIONS

h:140mm

FINISH AVAILABLE

Black Glass with
Stainless Steel Trim

FEATURES

- Fan heating
- Push/pull opening
- Dishes for a meal for 6 people take approx 30mins to heat up to 75°C
- Extremely rigid to support the weight of an appliance on top
- Maximum capacity 25g
- 400W heating element with tangential fan
- 30-75°C adjustable thermostat
- Smooth slide soft-close drawer runners
- Non-slip base cover
- On/off light

INSTALLATION

- Diagram [p.242]
- Rated load 0.46kW
- Fuse rating 3A



CLASSIC WARMING DRAWERS



WMD2954



WMD1354

PRODUCT CODE

c WMD2954

c WMD1354

DIMENSIONS

h:300mm WMD2954
h:140mm WMD1354

FINISH AVAILABLE

Stainless Steel

FEATURES

- Fan heating
- Stainless steel, black-spot feature bar handle
- Dishes for a meal for 6 people take approx 30mins to heat up to 70°C

- Extremely rigid to support the weight of an appliance on top
- 400W heating element with tangential fan
- 30-70°C adjustable thermostat
- Smooth slide soft-close drawer runners
- 90 Minute cut-off audible timer
- Anti-slip removable drawer liner
- On/off light

WMD2954

UNIQUE FEATURES

- Maximum capacity 20kg or 12 dinner plates, 12 soup plates, 6 serving bowls and 2 platters

WMD1354

UNIQUE FEATURES

- Maximum capacity 10kg or 6 dinner plates, 6 soup plates, 3 serving bowls and 2 platters

INSTALLATION

- Diagram [p.242]
- Rated load 0.4kW
- Fuse rating 3A

Features

QUALITY INTERIOR

Precision engineered sliding runners give a high-quality feel. All models feature either a protective anti-slip mat or stylish black base.



Features

STAINLESS STEEL, BLACK-SPOT FEATURE BAR HANDLE

Featured on some models to complement our ovens and microwaves.

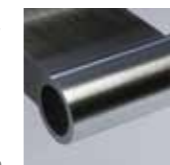

MINUTE MINDER

A mechanical timer controls the heating element, so when the timer sounds, the heater switches off too – no need to worry about over-heating.



STORAGE

Stylish, organised and convenient.

CLASSIC STORAGE DRAWER



PRODUCT CODE

C SD1356

DIMENSIONS

h:131mm

FINISH AVAILABLE

Fingerprint Resistant
Stainless Steel

FEATURES

- Push/pull opening
- Extremely rigid to support the weight of an appliance on top
- Maximum capacity 10kg
- Smooth slide soft-close drawer runners
- Attractive black interior glass base
- Storage drawer will take SDWINE and SDCOFFEE [see right] wooden inserts

INSTALLATION

- Diagram [p.242]



ADD YOUR ACCESSORIES

Both wooden inserts have been specially designed to hold all you need to make the perfect cup of coffee or enjoy your favourite glass of wine.

WINE ACCESSORY INSERT



PRODUCT CODE

SDWINE

DIMENSIONS

w:498mm
d:484mm
h:40mm

FINISH AVAILABLE

Solid Beech Wood

FEATURES

- Produced from solid beech wood
- Sections for various wine accessories including foil cutter, cork screw and thermometer
- 8 Separate storage sections
- Wine accessories not included
- Can only be used with SD1356

COFFEE ACCESSORY INSERT



PRODUCT CODE

SDCOFFEE

DIMENSIONS

w:498mm
d:484mm
h:40mm

FINISH AVAILABLE

Solid Beech Wood

FEATURES

- Produced from solid beech wood
- Sections for accessories including cups, spoons, coffee and sugar
- 7 Separate storage sections
- Coffee accessories not included
- Can only be used with SD1356



Range Cookers

Range cookers are a natural choice for discerning cooks. You can add a touch of flair and sophistication to your kitchen and satisfy the hungriest of households.



Our ovens take the benefits of range cookers to the next level. The majority of the ranges have electronic LED timers and every model comes with triple glazed heat reflective glass doors.

FLAME SAFE

A sensor in each burner immediately cuts the gas supply if the flame goes out.

CAST-IRON SUPPORTS

Gas hob models come with robust cast iron pan and wok supports to enable you to move the largest of pans smoothly from one burner to the other.



DOOR GLASS

Heat reflective doors. Triple-glazed and incorporating a full inner glass panel that's easily removed for cleaning.

ROTISSERIE

The CR9111 features a rotisserie for succulent oven roasting.



FULL WIDTH GLASS DOORS

All Caple range cookers have removable inner glass to make cleaning your oven less of a chore.



DRAWER STORAGE

Storage is made easy with a pull out sliding drawers. Ideal for stowing away your roasting tins, trays and frying pans.



CLASSIC DUAL FUEL DOUBLE CAVITY RANGE COOKER



CR9209

CLASSIC ELECTRIC DOUBLE CAVITY RANGE COOKER



CR9228

Features



All our range cookers have triple-glazed doors with heat-reflective glass. It means the oven door is cool to touch, while the heat is retained inside where it's needed. It's safer, more energy-efficient and it even makes for better cooking.

PRODUCT CODE

- C** CR9209
- C** CR9228

DIMENSIONS

- ↔** w:900mm

PERFORMANCE

- e** Main Oven A
- Small Oven B

FINISH AVAILABLE

- Stainless Steel with Black Glass

FUNCTIONS

8 Main Oven

- Light
- Conventional heat
- Top heat
- Turbo base heat
- Grill
- Turbo grill
- Fan heat
- Turbo defrost

5 Small Oven

- Light
- Conventional heat
- Top heat
- Base heat
- Grill

CR9209 HOB FEATURES

5 Gas Burners

- 1 Rapid burner: 3kW
- 1 Simmer burner: 1kW
- 2 Semi-rapid burners: 1.75kW
- 1 Triple ring burner: 3.7kW
- Auto electronic ignition
- Flame safety device
- Cast iron pan and wok supports

CR9228 HOB FEATURES

5 Ceramic Plates

- 1 Single rapid zone: 1.8kW
- 2 Single simmer zones: 1.2kW
- 1 Expandable zone: 1.0-2.2kW
- 1 Variable zone: 1.1p-2.0kW
- Residual heat indicator lights for all zones

OVEN FEATURES

Main Oven

- 73 Litre capacity
- Fully programmable electronic LED timer

Small Oven

- 43 Litre capacity

General

- Triple glazed doors with heat reflective glass
- Full width glass doors with removable inner glass
- Closed door grilling
- Removable chrome shelf racks
- Tangential cooling fan
- Easy clean enamel
- Storage compartment
- LPG jets included [CR9209]

DESIGN

- Stainless steel, black-spot feature bar handles
- Stainless steel side panels
- Black glass doors

ACCESSORIES

- 1 Shelf with support racks in both main and small ovens
- 2 Grill pans with handles
- 1 Enamelled baking tray

OPTIONAL EXTRAS

- Main oven shelf [SHELF CR1]
 - Main oven enamelled baking tray [TRAY CR1]
 - 1 Set of telescopic runners [CAPRACK5]
 - Oven steam set [STEAMSET]
 - Small oven shelf [SHELF CR2]
- Visit cagle.co.uk for full range

INSTALLATION

- Diagram [p.242]
- Rated load 4.6kW [CR9209]
- Fuse rating 20 [CR9209]
- Rated load 12.78kW [CR9228]
- Fuse rating 56A [CR9228]

CLASSIC GAS SINGLE CAVITY RANGE COOKER



PRODUCT CODE

- C** CR9111

DIMENSIONS

- ↔** w:900mm

PERFORMANCE

- e** Energy Class A

FINISH AVAILABLE

- Stainless Steel with Black Glass

FUNCTIONS

- 4** Main Oven
- Light
- Gas grill
- Gas cooking
- Rotisserie cooking

HOB FEATURES

- 5** Gas Burners
- 1 Rapid burner: 3kW
- 1 Simmer burner: 1kW
- 2 Semi-rapid burners: 1.75kW
- 1 Triple ring burner: 3.7kW
- Auto electronic ignition
- Flame safety device
- Cast iron pan and wok supports

OVEN FEATURES

- 85 Litre capacity
- Minute minder [mechanical timer]
- Triple glazed door with heat reflective glass
- Full width glass doors with removable inner glass
- Closed door grilling
- Removable chrome shelf racks
- Tangential cooling fan
- Easy clean enamel
- Storage compartment
- LPG jets included

DESIGN

- Stainless steel, black-spot feature bar handle
- Stainless steel side panels
- Black glass door

ACCESSORIES

- 1 Shelf with support racks
- 1 Grill pan with handle
- 1 Enamelled baking tray
- 1 Rotisserie rack

OPTIONAL EXTRAS

- 1 Set of telescopic runners [CAPRACK5]
 - Oven shelf [SHELF CR3]
 - Enamelled baking tray [TRAY CR2]
- Visit cagle.co.uk for full range

INSTALLATION

- Diagram [p.242]
- Fuse rating 3A

CLASSIC DUAL FUEL SINGLE CAVITY RANGE COOKER



PRODUCT CODE

- C** CR9109

DIMENSIONS

- ↔** w:900mm

PERFORMANCE

- e** Energy Class A

FINISH AVAILABLE

- Stainless Steel with Black Glass

FUNCTIONS

- 5** Main Oven
- Light
- Grill
- Turbo grill
- Fan heat
- Turbo defrost

HOB FEATURES

- 5** Gas Burners
- 1 Rapid burner: 3kW
- 1 Simmer burner: 1kW
- 2 Semi-rapid burners: 1.75kW
- 1 Triple ring burner: 3.7kW
- Auto electronic ignition
- Flame safety device
- Cast iron pan and wok supports

OVEN FEATURES

- 103 Litre capacity
- Programmable electronic LED timer
- Triple glazed door with heat reflective glass
- Full width glass doors with removable inner glass
- Closed door grilling
- Removable chrome shelf racks
- Tangential cooling fan
- Easy clean enamel
- Storage compartment
- LPG jets included

DESIGN

- Stainless steel, black-spot feature bar handle
- Stainless steel side panels
- Black glass door

ACCESSORIES

- 1 Shelf with support racks
- 1 Grill pan with handle
- 1 Enamelled baking tray

OPTIONAL EXTRAS

- 1 Set of telescopic runners [CAPRACK5]
 - Oven shelf [SHELF CR3]
 - Enamelled baking tray [TRAY CR2]
- Visit cagle.co.uk for full range

INSTALLATION

- Diagram [p.242]
- Rated load 3.15kW
- Fuse rating 13A



Hobs

Whether you choose gas, electric or induction, Caple's advanced technology and unswerving eye for detail means real control and stylish good looks every time.



Choosing the right hob

MIX AND MATCH MODULAR HOBS

Any number of modules can be mixed together in any sequence. In fact, the options are almost endless [find out more on p.99].



INDUCTION

Uses leading-edge technology by creating a magnetic field between the hob and pan. They're quick, easy to use and energy efficient.



GAS

Most professional kitchens opt for gas. Heat is instant and control is intuitive. You can choose either stainless steel or coloured enamel finishes.



Developed with cutting-edge design and outstanding efficiency in mind, DirectHeat+ sends the heat upwards directly towards the base of the pan via 45° inclined flame. More heat hits the base of the pan rather than escaping around the sides, therefore decreasing boiling time and bringing food to temperature more rapidly.



ELECTRIC

The smooth glass finish of a ceramic hob makes cleaning easier. They're sleek and look very contemporary, making them ideal for more modern kitchens.





Induction Hobs

They're hygienic, more energy-efficient, safer and easier to use.

They work by creating a magnetic field between the hob and the pan. Heat is instant, and it's easy to control. Once you remove the pan, they cool down very quickly, which is handy if kids are about. They're more energy-efficient because they only heat the pan area itself, rather than all around it. In fact, they use around 25% less energy than some hobs.

MEMORY RECALL

After switching the hob off, it is possible to recall the last used settings with a couple of simple button presses.

AUTOMATIC PAN DETECTION

This feature detects when a suitable pan has been placed on a cooking zone, helping to eliminate the possibility of the hob being activated by a non-suitable object.

BOOSTER AND BOOSTER+

Saves time by increasing power for a quicker boiling time.

Booster+ provides even further power and performance.

BRIDGE FUNCTION

Our C970i, C856i and C875i [shown above] are multi zone induction hobs. They provide complete flexibility allowing either the use of individual zones or the ability to combine them to create larger cooking areas.

If you cook regularly using oversized pans such as fish kettles, these hobs will handle them with ease.



ANTI-OVERFLOW, BOIL CONTROL AND ANTI-OVERHEAT

Some models include intuitive features to make cooking that little bit easier. Anti-overflow automatically cuts off the cooking zone if liquid boils over onto the control panel.

Luckily boil control maintains a temperature of 94°C, just below boiling, whilst anti-overheat prevents the hob from overheating and damaging the elements, preserving the lifetime of your appliance.



PAUSE FUNCTION

This allows you to temporarily stop the entire hobs cooking activity and then restart it at the same settings.

LCD INDUCTION HOB

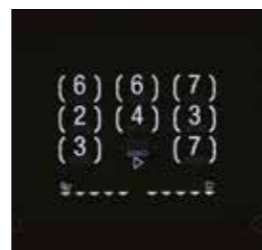

All 8 cooking zones shown



Chef Mode

PRODUCT CODE

C970i

DIMENSIONS

↔ w: 900mm

FINISH AVAILABLE

■ Black Glass

FEATURES

- Frameless with bevelled edge
- Touch control with white LCD screen
- 14 Level powder display for each zone [0-9, Bake 42°C, keep warm 70°C, boil control 93°C, Booster and booster+]
- Up to 8 cooking levels can be set at any one time

- Booster function and Booster+ on all 8 zones [p.76]
- Auto-bridge function to link zones for larger pans
- Chef Mode
- Heating area and delivered power automatically adapts to the pan
- 8 Programmable timers to set cooking duration and finishing time on each individual zone [up to 99 mins]
- Minute minder
- User programmable power levels
- Quick start short-cuts
- Adjustable brightness level for LCD screen
- Adjustable volume
- Memory recall function
- Pause function

- Child safety lock
- Residual heat indicators
- Automatic safety shut-off
- Automatic pan detection
- Anti-overheat
- Anti-over flow
- DEMO mode

INSTALLATION

- Diagram [p.243]
- Rated load 11.1kW
- Fuse rating 40A

Features

CHEF MODE

The chef mode creates three large zones, allowing you to cook with multiple pans at various temperatures all at the same time. For example, you can fry with intense heat then slide the pan over to a low temperature zone to keep it warm whilst you concentrate on other dishes.

COOKING OUTPUT

- 8 Induction Zones
- 220 x [180/38mm] - 2.1kW

OPTIONAL EXTRAS

- Cast iron induction griddle [iGRIDDLE]
- Visit caple.co.uk for full range



PRODUCT CODE

iGRIDDLE

DIMENSIONS

↔ 460 x 260 x 33mm

WEIGHT

kg 6.5kg

FEATURES

- Cast iron with food grade enamel coating
- Extra-large 840cm² cooking area [Plancha 490cm² and griddle 350cm²]
- Dishwasher safe
- Ergonomic handles
- Flat base for use on Caple induction hobs
- Adapted for use with C970i, C875i, C856i, DD935, DD940, also suitable for use on gas hobs

MULTI-ZONE INDUCTION HOB



PRODUCT CODE

C950i

DIMENSIONS

↔ Varies according to formation

FINISH AVAILABLE

■ Black Glass

FEATURES

- Frameless
- Slider touch control with direct access
- Can be flush mounted or inset [ALL 4 ZONES MUST BE INSTALLED]
- 11 Level digital power display for each zone [0-9 plus keep warm and Booster]
- Booster function on all zones [p.76]
- Programmable timer to set cooking duration and finishing time on each individual zone [up to 99 mins]
- Keep warm function
- Memory recall function
- Pause function

- Child safety lock
- Residual heat indicators
- Automatic safety shut-off
- Automatic pan detection
- Anti-overheat
- Anti-overflow

COOKING OUTPUT

- 4 Induction Zones
- 2 Dia. 300mm – 3kW
- 2 Dia. 270mm – 1.4kW

INSTALLATION

- Diagram [p.243]
- Rated load 7.4kW
- Fuse rating 25A

GAS AND INDUCTION HOB



PRODUCT CODE

C896iBK

DIMENSIONS

↔ w:780mm

FINISH AVAILABLE

■ Black Glass

FEATURES

- Black frameless
- Can be flush mounted
- 4 Induction zones,
- 1 gas wok burner
- 10 Level digital power display for each zone [0-9 + booster]
- Rotary touch control with direct access
- Programmable timer for each zone [up to 99mins] to set finish time
- Minute minder
- 2 Booster zones
- Pause function
- Residual heat indicators
- Automatic pan detection

- Automatic safety shut off
- Anti-overheat
- Child lock

GAS

- Flame safety device
- Cast iron pan supports
- Under burner tray
- Auto electronic ignition
- LPG jets included

COOKING OUTPUT

- 4 Induction Zones
- 2 Dia. 175mm – 1.4kW
- 2 Dia. 160mm – 3.0kW
- 1 Gas Burner
- 1 Triple ring burner 5kW

INSTALLATION

- Diagram [p.243]
- Rated load 7.4kW
- Fuse rating 32A

GAS AND INDUCTION HOB



PRODUCT CODE
C895iWH

DIMENSIONS

w:900mm

FINISH AVAILABLE

White Glass

FEATURES

- Bevelled edges

INDUCTION

- Audible touch control
- 9 Level digital power display for each zone
- 2 Booster zones [p.76]
- Programmable timer to set cooking duration and finishing time on each individual zone [up to 99 mins]
- Pause function
- Child safety lock
- Residual heat indicators

- Automatic safety shut-off
- Automatic pan detection
- Anti-overheat

GAS

- Flame safety device
- Cast iron pan supports
- Under burner tray
- Auto electronic ignition
- LPG jets included

COOKING OUTPUT

- 4** Induction Zones
- 1 Dia. 160mm – 1.4kW
 - 1 Dia. 160mm – 1.85kW
 - 1 Dia. 200mm – 2.3kW
 - 1 Dia. 200mm – 3kW
- 1** Gas Burner
- 1 Triple ring wok burner 4kW

INSTALLATION

- Diagram [p.243]
- Rated load 7.4kW
- Fuse rating 32A



INDUCTION HOB

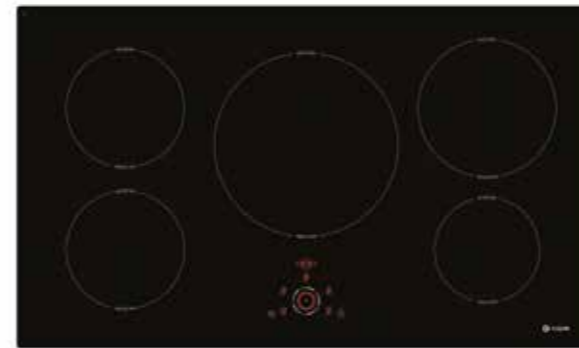

PRODUCT CODE
C900i

DIMENSIONS

w:880mm

FINISH AVAILABLE

Black Glass

FEATURES

- Frameless
- Rotary touch control with direct access
- Can be flush mounted or inset
- 11 Level digital power display for each zone [0-9, keep warm and Booster]
- Booster on each zone [p.76]
- Programmable timer to set cooking duration and finishing time on each individual zone [up to 99 mins]
- Memory recall function

- Pause function
- Child safety lock
- Residual heat indicators
- Automatic safety shut-off
- Automatic pan detection
- Anti-overheat
- Anti-overflow

COOKING OUTPUT

- 5** Induction Zones
- 1 Dia. 160mm – 1.4kW
 - 1 Dia. 180mm – 1.4kW
 - 1 Dia. 180mm – 2kW
 - 1 Dia. 210mm – 3kW
 - 1 Dia. 280mm – 3kW

INSTALLATION

- Diagram [p.243]
- Rated load 7.4kW
- Fuse rating 25A

INDUCTION HOB



PRODUCT CODE
C867i

DIMENSIONS

w:780mm

FINISH AVAILABLE

White Glass

FEATURES

- Frameless
- Audible touch controls
- Can be flush mounted or inset
- 9 Level LED power display for each zone
- 2 Booster zones [p.76]
- Programmable timer to set cooking duration and finishing time on each individual zone [up to 99 mins]

- Child safety lock
- Residual heat indicators
- Automatic safety shut-off
- Automatic pan detection
- Anti-overheat
- Anti-overflow

COOKING OUTPUT

- 4** Induction Zones
- 2 Dia. 170mm – 1.4kW
 - 2 Dia. 210mm – 3kW

INSTALLATION

- Diagram [p.243]
- Rated load 7.4kW
- Fuse rating 2

RIBBON INDUCTION HOB



**Auto-on function:
Once the hob is switched on and a pan is placed on the required zone the corresponding power display automatically illuminates ready for use.*



***Bridge function:
Bridge function can be used to create 2 large zones for use with oversized pans such as fish kettles.*

PRODUCT CODE
C875i

DIMENSIONS

w:910mm

FINISH AVAILABLE

Black Glass

FEATURES

- Frameless
- Slider touch control with direct access
- Can be flush mounted or inset
- 14 Level digital power display for each zone [0-9, bake 42°C, keep warm 70°C, boil control 94°C, Booster and Booster+]
- Booster and Booster+ function on all zones [p.76]
- Programmable timer to set cooking duration and finishing time on each individual zone [up to 99 mins]
- Auto-on* digital display
- Bridge** function to create 2 large zones

- Memory recall function
- Pause function
- Child safety lock
- Residual heat indicators
- Automatic safety shut-off
- Automatic pan detection
- Anti-overheat
- Anti-overflow

COOKING OUTPUT

- 4** Induction Zones
- 220 x 180mm – 3.7kW

OPTIONAL EXTRAS

- Cast iron induction griddle iGRIDDLE
- Visit caple.co.uk for full range

INSTALLATION

- Diagram [p.243]
- Rated load 7.4kW
- Fuse rating 25A

INDUCTION HOB



PRODUCT CODE

C856i

DIMENSIONS

w:590mm

FINISH AVAILABLE

Black Glass

FEATURES

- Black Frameless
- Slider touch control
- Bridgeable zones
- 10 Level digital power display for each zone [0-9 plus Booster]
- Booster on each zone [p.76]
- Programmable timer for each zone to set finish time [up to 99 mins]
- Pause function
- Safety lock
- Residual heat indicators
- Automatic pan and small object detection
- Automatic safety shut-off
- Anti-overheat

COOKING OUTPUT

- 4** Induction Zones
- 4 Dia. 220mm – 3kW
- 2** Alternative Dual Zones
- 2 Dia. 220 x 400mm – 4kW

OPTIONAL EXTRAS

- Cast iron induction griddle [iGRIDDLE]
- Visit caple.co.uk for full range

INSTALLATION

- Diagram [p.244]
- Rated load 7.0kW
- Fuse rating 32A

Features

BRIDGEABLE ZONES

The C856i zones provide complete flexibility in allowing either use of 4 individual zones, the option to combine zones into 2 larger zones for use with oversized pans or fish kettles.

INDUCTION HOB



PRODUCT CODE

C864i

DIMENSIONS

w:780mm

FINISH AVAILABLE

Black Glass

FEATURES

- Black glass frameless
- Can be flush mounted
- Slider touch control with direct access
- 10 Level digital power display for each zone [0-9 plus Booster]
- Booster on each of the 4 zones [p.76]
- Individual timer for each of the 4 zones
- 99 Minute minder
- Pause function
- Child safety lock
- Residual heat indicators
- Automatic safety shut-off
- Automatic pan detection
- Anti-overheat

COOKING OUTPUT

- 4** Induction Zones
- 2 Dia. 215mm - 2.1kW
- 2 Dia. 175mm – 1.85kW

INSTALLATION

- Diagram [p.244]
- Rated load 7.4kW
- Fuse rating 25A

INDUCTION HOB



PRODUCT CODE

C854i

DIMENSIONS

w:590mm

FINISH AVAILABLE

Black Glass

FEATURES

- Frameless
- Slider touch control with direct access
- 10 Level digital power display for each zone [0-9 plus Booster]
- Booster on each zone [p.76]
- 99 Minute timer
- Child safety lock
- Residual heat indicators
- Automatic safety shut-off
- Automatic pan detection

COOKING OUTPUT

- 4** Induction Zones
- 2 Dia. 140mm – 1.5kW with Booster
- 2 Dia. 220mm – 2.6kW with Booster

INSTALLATION

- Diagram [p.244]
- Rated load 7kW
- Fuse rating 32A



PRODUCT CODE

C850i

DIMENSIONS

w:590mm

FINISH AVAILABLE

Black Glass

FEATURES

- Frameless
- Touch control
- 9 Level digital power display for each zone
- 99 Minute timer
- Child safety lock
- Residual heat indicators
- Automatic safety shut-off
- Automatic pan detection

COOKING OUTPUT

- 4** Induction Zones
- 2 Dia. 140mm - 1.5kW
- 2 Dia. 180mm – 2kW

INSTALLATION

- Diagram [p.244]
- Rated load 7.2kW
- Fuse rating 32A

INDUCTION HOB - 13 AMP

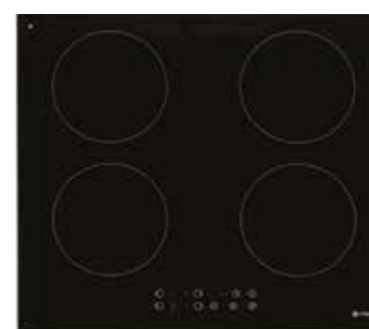

PRODUCT CODE

C840i

DIMENSIONS

w:590mm

FINISH AVAILABLE

Black Glass

FEATURES

- Frameless
- Touch control
- 9 Level digital power display
- 99 Minute timer
- Child safety lock
- Residual heat indicators
- Automatic safety shut-off
- Automatic pan detection
- Anti-overheat
- Supplied with a 13A plug for easy installation in any kitchen

COOKING OUTPUT

- 4** Induction Zones
- 2 Dia. 180mm – 1.5kW
- 2 Dia. 180mm – 2kW

INSTALLATION

- Diagram [p.244]
- Rated load 3kW
- Fuse rating 13A



PLEASE NOTE: The C840i induction hob achieves a 13A connection by restricting the maximum load to 3kW, this is done by cleverly limiting the combined zones to a maximum power level sum of 12. For example if you had boiling water on power level 6 on one zone you could cook rice on power level 4 and gently warm food on level 2 on a third zone.



ELECTRIC CERAMIC HOBS



PRODUCT CODE
C824C

DIMENSIONS
w:780mm

FINISH AVAILABLE
Black Glass

- FEATURES**
- Frameless
 - Can be flush mounted
 - Touch control
 - 10 Level digital power display [0-9 + keep warm]
 - 4 Quick heat boosters
 - Programmable timer for each zone [up to 99mins] to set finish time
 - Minute timer
 - A timer for each cooking zone
 - Residual heat indicators
 - Child safety lock
 - Overflow protection
 - Automatic safety shut-off

COOKING OUTPUT
4 Ceramic Plates

- 1 dia. 135mm/210mm – 1.0kW - 2.2kW
- 1 dia. 110mm/180mm – 0.7kW - 1.7kW
- 2 dia. 145mm – 1.2kW

INSTALLATION

- Diagram [p.244]
- Rated load 6.3kW
- Fuse rating 25A

The Power of Electric Hobs

Caple's electric hobs are engineered with performance, versatility and ease of use in mind.

Each hob has four separate zones offering different sizes, with individual lights that glow when activated. Touch control models set seamlessly into the worktop, but if you prefer more traditional operation opt for one of the dial control models.

The smooth black glass makes cleaning easy and thanks to minimalist styling both our frameless ceramic models will fit into any type of kitchen.



PRODUCT CODE
C814C

DIMENSIONS
w:590mm

FINISH AVAILABLE
Black Glass

- FEATURES**
- Frameless
 - Touch control
 - 9 Level digital power display
 - 99 Minute timer
 - Residual heat indicators
 - Child safety lock
 - Automatic safety shut-off

COOKING OUTPUT
4 Ceramic Plates

- 2 Dia. 200mm – 1.8kW
- 2 Dia. 165mm – 1.2kW

INSTALLATION

- Diagram [p.244]
- Rated load 6kW
- Fuse rating 30A

ELECTRIC CERAMIC HOB

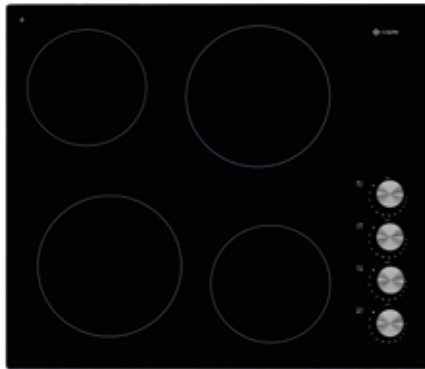

PRODUCT CODE
C807C

DIMENSIONS
w:590mm

FINISH AVAILABLE
Black Glass

FEATURES
- Frameless
- Indicator lights for each zone
- Residual heat indicators

COOKING OUTPUT
4 Ceramic Plates
- 2 Dia. 200mm – 1.8kW
- 2 Dia. 165mm – 1.2kW

INSTALLATION
- Diagram [p.244]
- Rated load 6kW
- Fuse rating 32A

ELECTRIC SEALED PLATE HOB



PRODUCT CODE
C605E

DIMENSIONS
w:580mm

FINISH AVAILABLE
Stainless Steel

FEATURES
- Neon indicator lights
- 6 Power levels

COOKING OUTPUT
4 Sealed Plates
- 1 Redspot plate:
Dia. 188mm – 2kW
- 2 Regular plates:
Dia. 155mm – 1kW
- 1 Regular plate:
Dia. 188mm – 1.5kW

INSTALLATION
- Diagram [p.244]
- Rated load 5.5kW
- Fuse rating 25A



Gas-on-Glass Hobs

Cool black or white glass. Sleek touch controls. Advanced engineering technology. If you're looking for a hob that combines contemporary design with power and functionality, this one ticks all the boxes.

That elegant glass surface doesn't just look stunning, it makes your hob simple to clean, while linked cast iron pan supports on most models let you easily transfer pans across burners or away from the heat. All burners are Flame Safe, so if a flame is extinguished for any reason, the gas supply is cut straight away. Some hobs also feature a responsive triple ring burner for extra powerful cooking.

Taking the gas-on-glass theme even further, we offer cool black or ice white tempered glass with bevelled edges for breathtakingly good looks. Precision cooking and sleek design-led finishing are the hallmark of Caple hobs.

PRECISION BUILT-IN

Touch controls set into black tempered glass look fabulous, but beauty is more than skin deep. Advanced digital technology gives you nine precise power levels on each burner, so they also offer an exceptional level of control. The look is pure Sense. The functionality is pure Caple.



TOUCH CONTROL GAS-ON-GLASS HOB



PRODUCT CODE

C981G

DIMENSIONS

↔ w:790mm

FINISH AVAILABLE

■ Black Glass

FEATURES

- Touch control
- 9 Level digital power display for each zone
- End of cooking timer
- Child safety lock
- Residual heat indicators
- Flame safety device with auto restart
- Cast iron pan supports
- Auto electronic ignition
- LPG jets included

COOKING OUTPUT

- 5** Gas Burners
- 1 Triple ring burner: 4kW
 - 1 Rapid burner: 3kW
 - 2 Semi-rapid burners: 1.75kW
 - 1 Simmer burner: 1kW

INSTALLATION

- Diagram [p.245]
- Fuse rating 3A

TOUCH CONTROL GAS-ON-GLASS HOB



PRODUCT CODE

C1081G

DIMENSIONS

↔ w:1000mm

FINISH AVAILABLE

■ Black Glass

FEATURES

- Touch control
- 9 Level digital power display for each zone
- End of cooking timer
- Child safety lock
- Residual heat indicators
- Flame safety device with auto restart
- Cast iron pan supports
- Auto electronic ignition
- LPG jets included

COOKING OUTPUT

- 4** Gas Burners
- 1 Triple ring burner: 4kW
 - 1 Rapid burner: 3kW
 - 1 Semi-rapid burner: 1.75kW
 - 1 Simmer burner: 1kW

INSTALLATION

- Diagram [p.245]
- Fuse rating 3A



GAS-ON-GLASS HOBBS



C870GBK

PRODUCT CODE

Black Glass C870GBK
White Glass C870GWH

DIMENSIONS

↔ w:770mm C870GBK
↔ w:770mm C870GWH

FINISH AVAILABLE

■ Black Glass
□ White Glass

FEATURES

- Bevelled edges
- Flame safety device
- Cast iron pan supports
- Under burner trays
- Auto electronic ignition
- LPG jets included



C870GWH

COOKING OUTPUT

- 5** Gas Burners
- 1 Triple ring burner: 4kW
 - 1 Rapid burner: 3kW
 - 2 Semi-rapid burners: 1.75kW
 - 1 Simmer burner: 1kW

INSTALLATION

- Diagram [p.245]
- Fuse rating 3A



GAS-ON-GLASS HOB



PRODUCT CODE
C871GBK

DIMENSIONS
w:680mm

FINISH AVAILABLE
Black Glass

- FEATURES**
- Black glass, with bevelled front edge
 - Flame safety device
 - Cast iron pan supports
 - Auto electronic ignition
 - LPG jets included

- COOKING OUTPUT**
- 5 Gas Burners
 - 1 Triple ring burner: 3.00kW
 - 1 Rapid burner: 2.40kW
 - 2 Semi-rapid burners 1.88kW
 - 1 Simmer burner: 0.9kW

- INSTALLATION**
- Diagram [p.245]
 - Fuse rating 3A

GAS-ON-GLASS HOBS

DirectHeat+



C789G

DirectHeat+



C787G

DirectHeat+



C786G

PRODUCT CODE

C789G
C787G
C786G

DIMENSIONS

w:874mm C789G
w:700mm C787G
w:584mm C786G

FINISH AVAILABLE

Black Glass with
Stainless Steel

FEATURES

- Black glass with stainless steel control panel
- DirectHeat+
- Flame safety device
- Cast iron pan supports
- Auto electronic ignition
- LPG jets included

COOKING OUTPUT

- 5 Gas Burners [C789G and C787G]
- 1 Triple ring burner: 4.2kW
- 1 rapid burner: 2.7kW
- 2 semi-rapid burners: 1.75kW
- 1 simmer burner: 1.0kW
- 4 Gas Burners [C786G]
- 1 Triple ring burner: 3.6kW
- 2 semi-rapid burners: 1.75kW
- 1 simmer burner: 1.0kW

INSTALLATION

- Diagram [p245]
- Fuse rating 3A

Features

DirectHeat+

Developed with cutting-edge design and outstanding efficiency in mind, DirectHeat+ sends the heat upwards directly towards the base of the pan via 45° inclined flame. More heat hits the base of the pan rather than escaping around the sides, therefore decreasing boiling time and bringing food to temperature more rapidly.

GAS-ON-GLASS HOBS



C769G



C759G



C739G

PRODUCT CODE

C769G
C759G
C739G

DIMENSIONS

↔ w:900mm C769G
w:750mm C759G
w:600mm C739G

FINISH AVAILABLE

■ Black Glass with
Stainless Steel

FEATURES

- Stainless steel front trim
- Flame safety device
- Cast iron pan supports
- Auto electronic ignition
- LPG jets included

COOKING OUTPUT

- 5** Gas Burners [C769G and C759G]
- 1 Triple ring burner: 3.8kW
 - 1 Rapid burner: 3kW
 - 2 Semi-rapid burners: 1.75kW
 - 1 Simmer burner: 1kW
- 4** Gas Burners [C739G]
- 1 Rapid burner: 3kW
 - 2 Semi-rapid burners: 1.75kW
 - 1 Simmer burner: 1kW

INSTALLATION

- Diagram [p.245]
- Fuse rating 3A



GAS-ON-GLASS HOBS



C744G



C944G

PRODUCT CODE

C744G
C944G

DIMENSIONS

↔ w:580mm C744G
w:750mm C944G

FINISH AVAILABLE

■ Black Glass

FEATURES

- Flame safety device
- Cast iron pan supports
- Auto electronic ignition
- LPG jets included

COOKING OUTPUT

- 4** Gas Burners [C744G]
- 1 Triple ring burner: 3.00kW
 - 2 semi-rapid burners: 1.88kW
 - 1 simmer burner: 0.9kW

- 5** Gas Burners [C944G]
- 1 Triple ring burner: 3.00kW
 - 1 Rapid burner: 2.40kW
 - 2 Semi-rapid burners 1.88kW
 - 1 Simmer burner: 0.9kW

INSTALLATION

- Diagram [p.246]
- Fuse rating 3A

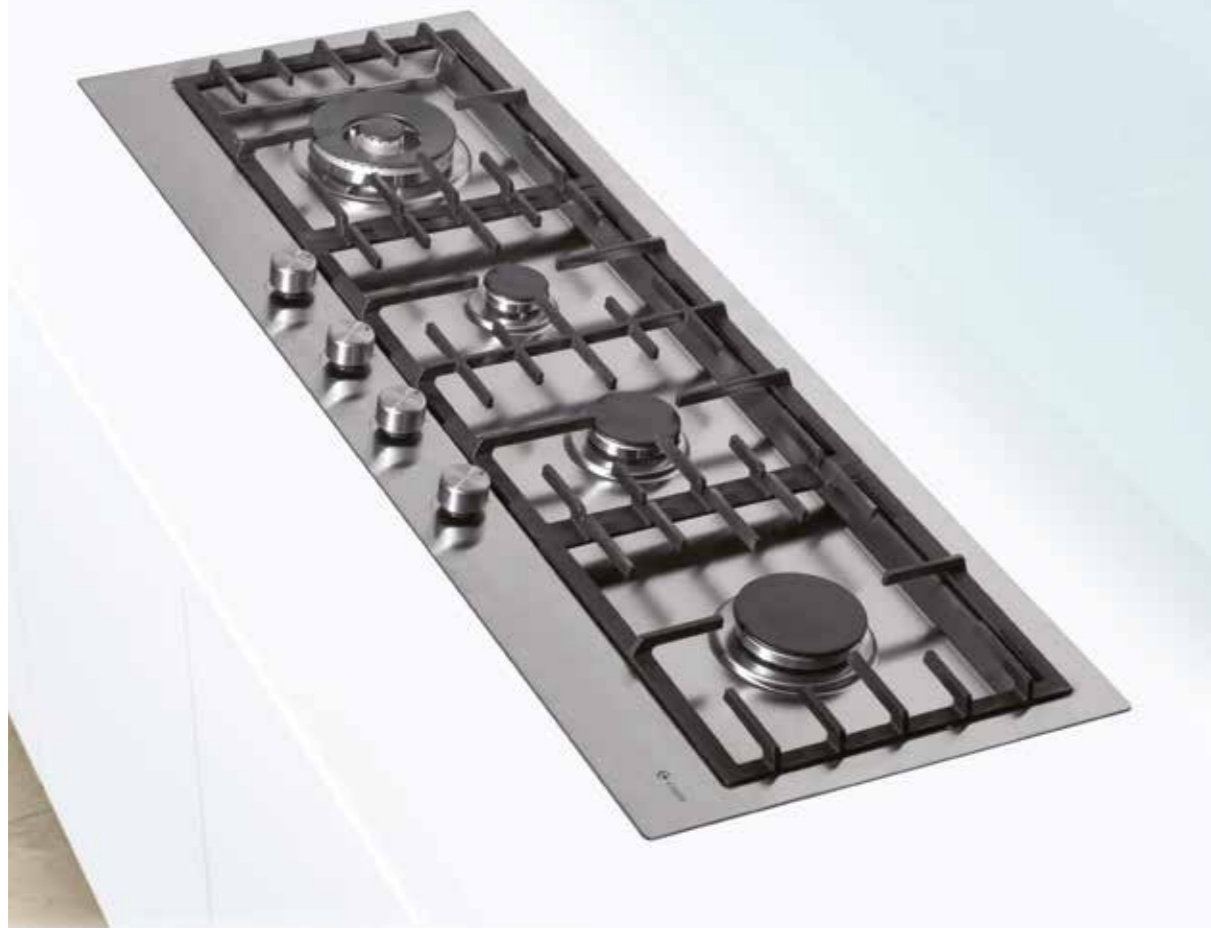

Flush Mounted Gas Hobs

The look says it all. Designed to fit perfectly with the clean and uncluttered lines of a modern kitchen, this innovative hob offers more than superb styling, it provides real practical advantages too.

Flush mounted or inset into your worktop, the recessed hob is the ideal match for solid surface worktop materials like marble, granite or slate. Flat cast iron supports mean that you can move pans across the hob effortlessly, and Caple's Flame Safe feature gives you peace of mind – if a flame goes out – the gas supply is cut almost immediately. Both models also feature a powerful triple ring burner.

CLEAN LINES

With their elegant low-profile recessed design and smart styling, these superb hobs maintain the clean linear look of your kitchen. They're thoroughly practical too - the hob's recess catches any spills and makes it easy to wipe down and clean.

FLUSH MOUNTED GAS HOB



PRODUCT CODE
C972G

DIMENSIONS

↔ w:890mm

FINISH AVAILABLE

■ Stainless Steel

FEATURES

- Can be flush mounted or inset
- Flame safety device
- Cast iron pan supports
- Auto electronic ignition
- LPG jets included

COOKING OUTPUT

- 5** Gas Burners
- 1 Triple ring burner: 3.8kW
 - 1 Rapid burner: 3kW
 - 2 Semi-rapid burners: 1.75kW
 - 1 Simmer burner: 1kW

INSTALLATION

- Diagram [p.246]
- Fuse rating 3A

FLUSH MOUNTED GAS HOB



PRODUCT CODE
C1072G

DIMENSIONS

↔ w:1100mm

FINISH AVAILABLE

■ Stainless Steel

FEATURES

- Can be flush mounted or inset
- Flame safety device
- Cast iron pan supports
- Auto electronic ignition
- LPG jets included

COOKING OUTPUT

- 4** Gas Burners
- 1 Triple ring burner: 4kW
 - 1 Rapid burner: 3kW
 - 1 Semi-rapid burner: 1.75kW
 - 1 Simmer burner: 1kW

INSTALLATION

- Diagram [p.246]
- Fuse rating 3A





Low Profile Gas Hobs

Unrivalled performance and looks, coupled with ease of fitting. Caple low profile hobs are designed to sit on top of the work surface with the smallest of edges.

They give you the appearance of a professional kitchen with added Caple refinement.

LOW PROFILE GAS HOBS



C873G



C866G



C848G

PRODUCT CODE

C873G
C866G
C848G

DIMENSIONS

↔ w:890mm C873G
w:750mm C866G
w:590mm C848G

FINISH AVAILABLE

■ Stainless Steel

FEATURES

- Flame safety device
- Cast iron pan supports
- Auto electronic ignition
- LPG jets included

COOKING OUTPUT

- 5** Gas Burners [C873G and C866G]
- 1 Triple ring burner: 3.8kW
 - 1 Rapid burner: 3kW
 - 2 Semi-rapid burners: 1.75kW
 - 1 Simmer burner: 1kW
- 4** Gas Burners [C848G]
- 1 Rapid burner: 3kW
 - 2 Semi-rapid burners: 1.75kW
 - 1 Simmer burner: 1kW

INSTALLATION

- Diagram [p.246]
- Fuse rating 3A



GAS HOBS



C774G



C767G



C749G

PRODUCT CODE

C774G

C767G

C749G

DIMENSIONS

↔	w:860mm	C774G
	w:750mm	C767G
	w:590mm	C749G

FINISH AVAILABLE

■ Stainless Steel

FEATURES

- Flame safety device
- Cast iron pan supports
- Auto electronic ignition
- LPG jets included

COOKING OUTPUT

- 5** Gas Burners [C774G and C767G]
- 1 Triple ring burner: 3.3kW
 - 1 Rapid burner: 3kW
 - 2 Semi-rapid burners: 1.75kW
 - 1 Simmer burner: 1kW
- 4** Gas Burners [C749G]
- 1 Rapid burner: 3kW
 - 2 Semi-rapid burners: 1.75kW
 - 1 Simmer burner: 1kW

INSTALLATION

- Diagram [p.246]
- Fuse rating 3A

GAS HOB



C706G

PRODUCT CODE

C706G

DIMENSIONS

↔	w:580mm
---	---------

FINISH AVAILABLE

■ Stainless Steel

FEATURES

- Flame safety device
- Enamelled pan supports
- Auto electronic ignition
- LPG jets included

COOKING OUTPUT

- 4** Gas Burners
- 1 Triple ring burner: 3.0kW
 - 2 Semi-rapid burners: 1.88kW
 - 1 Simmer burner: 0.9kW

INSTALLATION

- Diagram [p.246]
- Fuse rating 3A



Modular Hobs

Now you can build the perfect hob for your needs. Combine gas, electric, induction and modular extraction for a truly bespoke solution that's sure to impress.

Our auto-ignition gas hob has cast iron pan supports. When coupled with powerful downdraft extraction it offers a clean, fully integrated design throughout – bespoke and beautiful.



Combine two, three, four or more modules, of any type and in any sequence. Introduce induction cooking into your kitchen by combining it with gas or electric, or wow with tepan [a grill plate perfect for flash frying].

TEPAN HOB



PRODUCT CODE
C995T

DIMENSIONS
w:380mm

FINISH AVAILABLE
Stainless Steel with Black Glass

FEATURES

- Black glass frame
- Automatic stop and temperature limiter
- Residual heat indicator
- Maximum temperature 240°C

COOKING OUTPUT
1 Cooking Zone
- 380 x 380mm – 2.5kW

INSTALLATION

- Diagram [p.247]
- Rated load 2.5kW
- Fuse rating 16A

INDUCTION MODULAR HOB

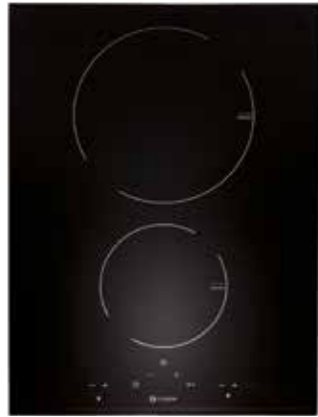

PRODUCT CODE
C996i

DIMENSIONS
w:380mm

FINISH AVAILABLE
Black Glass

FEATURES

- Polished aluminium trim
- Touch control
- 9 Level digital power display for each zone
- Booster function on both zones to access maximum temperature quickly

- Timer [up to 99mins] with audible alarm and auto switch-off

- Automatic stop and temperature limiter
- Child safety lock
- Residual heat indicators
- Automatic pan detection

COOKING OUTPUT
2 Induction Zones
- 1 Dia. 200mm – 2kW [with 3kW Booster]
- 1 Dia. 160mm – 1.6kW

INSTALLATION

- Diagram [p.247]
- Rated load 3.6kW
- Fuse rating 16A

GAS-ON-GLASS MODULAR HOB



PRODUCT CODE
C993G

DIMENSIONS
w:380mm

FINISH AVAILABLE
Black Glass

FEATURES

- Polished aluminium trim
- Flame safety device

- Cast iron pan support

- Auto electronic ignition
- LPG jets included

COOKING OUTPUT
2 Gas Burners
- 1 Rapid burner: 3kW
- 1 Semi-rapid burner: 1.75kW

INSTALLATION

- Diagram [p.247]
- Fuse rating 3A

INDUCTION MODULAR HOB



PRODUCT CODE
C994i

DIMENSIONS
w:288mm

FINISH AVAILABLE
Black Glass

FEATURES

- Frameless
- Audible touch control
- 9 Level digital power display for each zone
- Timer [up to 99mins] with audible alarm and auto switch-off

- Automatic stop and temperature limiter

- Child safety lock
- Residual heat indicators
- Automatic pan detection

COOKING OUTPUT
2 Induction Zones
- 1 Dia. 140mm – 1.5kW
- 1 Dia. 180mm – 2kW

INSTALLATION

- Diagram [p.247]
- Rated load 3.5kW
- Fuse rating 16A

ELECTRIC CERAMIC MODULAR HOB



PRODUCT CODE
C892C

DIMENSIONS
:288mm

FINISH AVAILABLE
Black Glass

FEATURES

- Frameless
- Audible touch control
- 9 Level digital power display for each zone
- Timer [up to 99mins] with audible alarm and auto switch-off
- Automatic stop and temperature limiter
- Child safety lock
- Residual heat indicators

COOKING OUTPUT
2 Ceramic Plates
- 1 Dia. 165mm – 1.2kW
- 1 Dia. 200mm – 1.8kW

INSTALLATION

- Diagram [p.247]
- Rated load 3kW
- Fuse rating 13A



Extraction

A well-engineered extractor hood does more than just help to capture odours from your kitchen. Be bold, and use it as a visual focal point too.



Choosing the perfect hood

We've designed one for every kind of kitchen. Striking colours, exceptional finishes, and plenty of functionality.

Extractors and hoods are designed to remove cooking odours, moisture and grease from the cooking environment. The extractor continually removes and filters the air when on. It then, either, returns the filtered air back in to the room or expels it through an external vent. The greater the extraction rate the more effectively this is done.

GETTING THE BEST FROM YOUR HOOD

One useful technique is to switch on the extractor or hood 15 minutes before you begin cooking. This creates kinetic air circulation within the kitchen carrying the air out more effectively. It is also advisable to keep it running for a further 15 minutes after you have finished cooking.

You can sit down and enjoy the results of your culinary skills whilst your Caple extractor or hood gets on with its job.

Once you have chosen your extractor, it is important to pair it with the correct venting. It is essential the stated ducting diameter is used, we also recommend rigid ducting to ensure you get the maximum performance. Not only will this prolong the life of your extractor, it will also improve efficiency.

If you choose to vent your extractor to the outside world, look out for the venting symbol shown to assist you in choosing the correct product. Please see page 158-159 for more information.

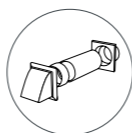

INDUCTION DOWNDRAFT

This award-winning category of extraction is ideal for open plan living. The powerful extraction eradicates cooking odours from the room and the minimal aesthetics discreetly blends into the worktop for a seamless look.



DOWNDRAFT EXTRACTORS

This type of counter extractor is installed behind or alongside your hob. When you need it, just press the button and it glides up into position.



CEILING HOODS

They're unobtrusive and they save you space too. You can choose different motors and have complete control over extraction rates.



ISLAND HOODS

Better suited to larger kitchens. You can suspend them over a central island unit to make a stunning focal point.



WALL CHIMNEY HOODS

Available in all kinds of sizes, styles and finishes. Great for a dramatic centrepiece.



BUILT-UNDER HOODS

Ideal for smaller kitchens. They're cleverly integrated into the underside of kitchen units.



INTEGRATED HOODS

Discreetly hidden behind kitchen furniture, and pulled out when needed.



CONVENTIONAL HOODS

This type fits snugly beneath a kitchen unit, with controls usually found on the front.



Induction Downdraft Extractors

SEAMLESS INTEGRATION, AND UNMISTAKABLE STYLING.

As the name suggests induction downdrafts combine intuitive induction hobs with the added benefit of integrated, powerful downdraft extraction.

You can choose from a traditional downdraft that rises from the surface and disappears beneath the worktop when inactive or a fully integrated option that extracts from the surface.

SPACE SAVING INSTALLATION

With some models a unique space-saving installation can be used with minimal ducting and the motor located behind the plinth which means you can still utilise the cabinets directly underneath the hob. For installation see pages 247-250.



With the DD940BK, you have the option to use our new Plasma technology. This allows you to recirculate the air with very efficient odour removal process.

The Plasma filter and charcoal filter are cleverly hidden away in the plinth below the cabinets, so there is no need to vent the product to the outside wall. Please see p.247 for installation details. You can also install all of the pipework into a 300mm wide carcass allowing for a lot more use of the kitchen cupboard in comparison to a conventional downdraft.



The Plasma technology also extends the life of the charcoal filter from around 6 months to 5 years, 1 filter will last the equivalent of 10 when Plasma technology is used.

Engineered and manufactured in Germany, we have developed an innovative method using plasma to purify and filter the air eliminating any trace of odours in your kitchen.

The filter creates the fourth state of matter, plasma. Any air travelling through the filter is purified by the plasma, removing 95% of all odours. The air then travels through the carbon filter to eliminate any stubborn odour. Clean air is then recirculated back into the room.



INDUCTION HOB & DOWNDRAFT EXTRACTOR

PRODUCT CODE
DD940BK

DIMENSIONS
w:900mm

PERFORMANCE
Energy Class A+
Fluid dynamic efficiency A
Grease absorption A
Annual Consumption
32.3kWh/yr
Max. extraction 650m³/h
Max. noise level 64dB

FINISH AVAILABLE
Black Glass

GENERAL FEATURES
- 5 Year guarantee

FEATURES

Hob

- Frameless
- Can be flush mounted
- Slider touch control
- Large cooking area
- 10 Power level digital display for each zone [0-9 plus booster]
- Booster function on all zones, including Auto Boost mode
- Bridge function to combine 2 zones
- Timer for each zone / minute minder

- Memory recall function
- 3 preset temperatures settings [bake 42°C, keep warm 70°C, boil control 92°C]
- Pause function
- Child safety lock
- Residual heat indicators
- Automatic safety shut-off
- Anti-overheat
- Auto pan detection

Downdraft

- Touch control
- 4 speeds
- Auto timer
- Aluminium grease filters
- Required ducting size 150mm

- Plinth motor included
- Optional plasma filter

COOKING OUTPUT
- 190 X 220mm - 3.7kW

OPTIONAL EXTRAS

- Plasma filter [PLASMAX]
 - Recirculation kit [CAP57CF]
 - Removable grille cover [GRILLE/DD940BK]
 - Cast iron induction griddle [iGRIDDLE]
- Visit caple.co.uk for full range

INSTALLATION

- Space saving installation diagram [p.247]
- Venting Kits [p.158]

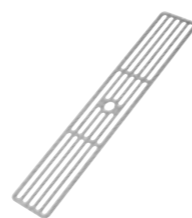

GRILLE/DD940BK

▶ **PLASMA EXPLAINED** Watch our plasma video online at www.caple.co.uk

PLASMA TECHNOLOGY



The powerful, ultra quiet motor draws the cooking vapour through the 12 stage filter, removing grease and moisture.



Discreetly positioned behind the plinth, the motor draws the air through the ducting, on towards the filters.

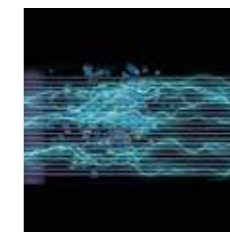

The first filter creates the 4th stage of matter, Plasma. A trusted technology developed by the German university of Göttingen. The Plasma removes 95% of the odours passing through it.



A carbon filter removes any remaining odours and has an anticipated life span of 5 years or more when used with a plasma filter.



Clean air is then recirculated back into the room.



INDUCTION DOWNDRAFT EXTRACTOR HOB

PRODUCT CODE
DD935BK

DIMENSIONS
w:780mm

PERFORMANCE
Energy Class B
Max. extraction 655m³/h
[speed 1 286m³/h,
speed 2 374m³/h,
speed 3 497m³/h,
speed 4 655m³/h]

FINISH AVAILABLE
Black Glass

FEATURES

Hob

- Black glass with flush black downdraft grille
- Frameless
- Slider touch controls
- 13 power levels [0-9, bake 42°C, keep warm 70°C, boil control 94°C and Booster] Booster function on all zones
- Timer function
- Keep warm function
- Pause and memory recall function
- Bridge function
- Automatic heat-up function
- Child safety lock
- Residual heat indicators
- Anti-overheat protection
- Automatic safety shut-off
- Auto pan detection

Downdraft

- 4 Speeds [inc. Boost function]
- Auto timer – switch-off after 10mins
- Aluminium grease filter
- Ducting spigot size 150mm
- Motor included
- Recirculation kit available

COOKING OUTPUT

- 4 Induction Zones
- 184x220mm – 3.7kW

MOTOR CHOICES

- Downdraft extractors will need to be purchased with a motor. For the full range please see p.126-131.

OPTIONAL EXTRAS

- Washable charcoal filter [CAP76CF]
 - Cast iron induction griddle [iGRIDDLE]
- Visit caple.co.uk for full range

INSTALLATION

- Diagram [p.248]



INDUCTION DOWNDRAFT EXTRACTOR WITH LIGHT

PRODUCT CODE
DD931BK

DIMENSIONS
w:898mm

PERFORMANCE
Energy Class A-C
For energy and performance see p.142-145

FINISH AVAILABLE
Black Glass

FEATURES

Hob

- Frameless with bevelled edge
- Slider touch control
- 10 Power level digital display for each zone [0-9 plus Booster]
- Booster function on all zones [p.76]
- Bridge function to combine 2 zones
- Timer
- Memory recall function
- Keep warm function
- Pause function
- Child safety lock
- Residual heat indicators
- Automatic safety shut-off
- Anti-overheat

Downdraft

- Touch control
- 4 Speeds
- Auto timer
- 5W LED light strip
- Aluminium grease filters
- Required ducting size 150mm
- Motor not included

COOKING OUTPUT

- 4 Induction Zones
- 184x220mm – 3.7kW

MOTOR CHOICES

- Downdraft extractors will need to be purchased with a motor. For the full range please see p.126-131.

OPTIONAL EXTRAS

- Recirculation kit [CAP43CF only for use with motors DDMEXT11 and DDMEXT28]
- Visit caple.co.uk for full range

INSTALLATION

- Diagram [p.248]

Features

ILLUMINATED LIGHTING

Cool white neon lighting adds sophistication and style, while complementary blue illuminated soft-touch buttons put completely intuitive control at your fingertips.

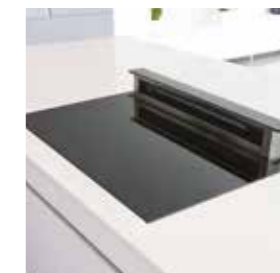



Downdraft Extractors

Caple downdraft extractors are the epitome of intelligent thinking in kitchen design. With an ingenious under-counter installation, wall space is kept clear and when integrated into an island unit, views across the kitchen remain uncluttered.

A downdraft extractor can be housed either behind or alongside a hob, in an island unit or within a base against a wall. Fitting elegantly into the surface until activated, it rises out of the worktop beyond the height of the pans to extract odours directly from the cooking area.

These smart extractors deliver high extraction rates and give you a choice of motors and motor positioning options to suit your kitchen design. For example, your motor could be situated under the floor, on an external wall or in a cupboard, so noise can be virtually eliminated [p.126-131]. With real versatility, our downdraft extractors can expel air via ducting or recirculate it using charcoal filters.

SLEEK STYLING

Most of our downdrafts feature touch control technology and are designed to complement the appliances within the Sense Premium and Sense ranges.

SMOOTH OPERATOR

At the touch of a button, the DD925CO rises smoothly up from its flush, retracted position.



MOTOR CHOICES

Downdraft extractors will need to be purchased with a motor. For the full range please see p.126-131.



INVISIBLE MOTOR

The DDMEXT28 is designed to be easily and discreetly installed behind the plinth without the requirement of ducting to the outside of the building. For more details see p.127.

FLUSH FITTING

Designed to tuck neatly away into your work surface until needed, then acting as a sleek centrepiece when in use.





NOSTA

DOWNDRAFT EXTRACTOR WITH LIGHT

PRODUCT CODE
DD925CO

DIMENSIONS
w:880mm

PERFORMANCE
Energy Class A-C
For energy and performance see p.128-131

FINISH AVAILABLE
Black glass with copper

FEATURES

- For use with gas or electric hobs
- 4 Speeds [inc. Boost function]
- Auto timer – switch-off after 10mins
- 14W white LED light

- Remote control operated
- Polished stainless steel grease filters
- Ducting spigot size 150mm
- Motor not included
- Recirculation kit available

MOTOR CHOICES

- Downdraft extractors will need to be purchased with a motor. For the full range please see p.126-131.

OPTIONAL EXTRAS

- Recirculation kit [CAP68CF - only for use with motors DDMEXT11 and DDMEXT28]

Visit caple.co.uk for full range

INSTALLATION

- Diagram [p.249]
- Venting Kits [p.158]
- The electric's box must be located at least 650mm from the hob



DD925CO closed

DOWNDRAFT EXTRACTOR WITH LIGHT

PRODUCT CODE
DD120BK

DIMENSIONS
w:1175mm

PERFORMANCE
Energy Class A-C
For energy and performance see p.128-131

FINISH AVAILABLE
Black Glass with Stainless Steel

FEATURES

- Illuminated touch controls
- For use with gas or electric hobs
- Perimetrical extraction for reduced noise and increased pressure resulting in improved motor performance
- 4 Speeds [inc.Boost function]

- Auto timer – switch-off after 10mins
- Bright 21W white neon light
- Aluminium grease filters
- Required ducting size 150mm
- Recirculation kit available
- Motor not included

MOTOR CHOICES

- Downdraft extractors will need to be purchased with a motor. For the full range please see p.126-131.

OPTIONAL EXTRAS

- Recirculation kit [CAP69CF - only for use with motors DDMEXT11 and DDMEXT28]

Visit caple.co.uk for full range

INSTALLATION

- Diagram [p.248]
- Venting Kits [p.158]
- The electric's box must be located at least 650mm from the hob



Venting choices

Ensure you purchase the correct venting for your Caple extractor. For the full range please see p.158-159

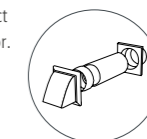



FLUSH DOWNDRAFT EXTRACTORS WITH LIGHT

PRODUCT CODE

Stainless Steel	DD911SS
White Glass	DD911WH
Black Glass	DD911BK



DIMENSIONS

↔ w:875mm

PERFORMANCE

e Energy Class A-C
For energy and performance see p.128-131

FINISH AVAILABLE

-  Stainless Steel
-  White Glass with Stainless Steel
-  Black Glass with Stainless Steel

FEATURES

- Illuminated touch control
- For use with gas or electric hobs
- Perimetrical extraction for reduced noise and increased pressure resulting in improved motor performance
- 4 Speeds [inc. Boost function]

- Auto timer switch-off after 10mins
- Bright 14W white neon light
- Aluminium grease filters
- Required ducting size 150mm 
- Motor not included
- Recirculation kit available

MOTOR CHOICES

- Downdraft extractors will need to be purchased with a motor. For the full range please see p. 140-145

OPTIONAL EXTRAS

- Recirculation kit [CAP43CF - only for use with motors DDMEXT11 and DDMEXT28]

Visit caple.co.uk for full range

INSTALLATION

- Diagram [p.249]
- Venting Kits [p.158]
- The electric box must be located at least 650mm from the hob



DD911SS



DD911WH



DD911BK

PUSH DOWNDRAFT EXTRACTOR WITH LIGHT



PRODUCT CODE

DD901BK

DIMENSIONS

↔ w:810mm

PERFORMANCE

e Energy Class B-C
For energy and performance see p.128-131

FINISH AVAILABLE

-  Black Glass with Stainless Steel

FEATURES

- Electronic push button controls
- Perimetrical extraction for reduced noise and increased pressure resulting in improved motor performance
- For use with gas or electric hobs
- 4 Speeds [inc. Boost function]
- Auto timer – switch-off after 10mins
- 2 x 3.9W white LED lights
- Stainless steel and aluminium grease filters
- Required ducting size 150mm 
- Motor not included
- Recirculation kit available

Venting choices

Ensure you purchase the correct venting for your Caple extractor. For the full range please see p.158-159

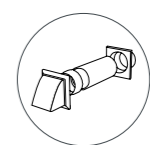

MOTOR CHOICES

- Downdraft extractors will need to be purchased with a motor. For the full range please see p. 140-145

OPTIONAL EXTRAS

- Recirculation kit [CAP67CF - only for use with motors DDMEXT11 and DDMEXT28]

Visit caple.co.uk for full range

INSTALLATION

- Diagram [p.250]
- Venting Kits [p.158]
- The electric box must be located at least 650mm from the hob





MODULAR FLIP DOWNDRAFT EXTRACTOR



PRODUCT CODE
DD522BK

DIMENSIONS
w:520mm

PERFORMANCE
Energy Class B-C
For energy and performance see p.142-145

FINISH AVAILABLE
Black Glass with Stainless Steel

- FEATURES**
- Illuminated touch controls
 - For use with gas or electric hobs
 - Perimetrical extraction for reduced noise and increased pressure resulting in improved motor performance
 - Extracts from both sides, ideal for installation between modular hobs
 - 4 Speeds
 - Auto timer – switch-off after 10mins

- Aluminium grease filters
- Required ducting size 150mm
- Motor not included
- Recirculation kit available

MOTOR CHOICES
- Downdraft extractors will need to be purchased with a motor. For the full range please see p.126-131.

OPTIONAL EXTRAS
- Recirculation kit [CAP72CF - only for use with motor DDMEXT28]
Visit caple.co.uk for full range

INSTALLATION
- Diagram [p.250]
- Venting Kits [p.158]
- The electrics box must be located at least 650mm from the hob

Venting choices

Ensure you purchase the correct venting for your Caple extractor. For the full range please see p.158-159

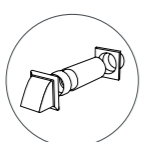

DOWNDRAFT EXTRACTORS



PRODUCT CODE
Stainless Steel DD606SS
Black Glass DD606BK

DIMENSIONS
w:575mm

PERFORMANCE
Energy Class B-C
For energy and performance see p.128-131

FINISH AVAILABLE
Stainless Steel
Black Glass with Stainless Steel

- FEATURES**
- Electronic controls on stainless steel finish, touch control on black glass finish
 - For use with gas or electric hobs
 - Perimetrical extraction for reduced noise and increased pressure resulting in improved motor performance

- 4 Speeds [inc. Boost function]
- Auto timer – switch-off after 10mins
- Aluminium grease filters
- Required ducting size 150mm
- Motor not included
- Recirculation kit available

MOTOR CHOICES
- Downdraft extractors will need to be purchased with a motor. For the full range please see p.126-131.

OPTIONAL EXTRAS
- Recirculation kit [CAP27CF - only for use with motors DDMEXT11 and DDMEXT28]
Visit caple.co.uk for full range

INSTALLATION
- Diagram [p.250]
- Venting Kits [p.158]
- The electrics box must be located at least 650mm from the hob

FLIP DOWNDRAFT



PRODUCT CODE
DD903BK

DIMENSIONS
w:845mm

PERFORMANCE
Energy Class A-C
For energy and performance see p.128-131

FINISH AVAILABLE
Black Glass with Stainless Steel

- FEATURES**
- Illuminated touch control
 - Motor speed indicator light
 - For use with gas or electric hobs
 - Perimetrical extraction for reduced noise and increased pressure resulting in improved motor performance
 - 4 Speeds
 - Auto timer – switch-off after 10mins
 - Aluminium grease filters

- Required ducting size 150mm
- Motor not included
- Recirculation kit available

MOTOR CHOICES
- Downdraft extractors will need to be purchased with a motor. This model can be used with DDMEXT20, DDMEXT 27 and DDMEXT30. For the full range please see p.126-131.

OPTIONAL EXTRAS
- Recirculation kit [2 x CAP66CF - only for use with motor DDMEXT28]
Visit caple.co.uk for full range

INSTALLATION
- Diagram [p.250]
- Venting Kits [p.158]
- The electrics box must be located at least 650mm from the hob



Ceiling Hoods

Style is nothing without functionality. Naturally, Caple's ceiling extractors come with both, as standard.

They're available in various sizes and engineered to achieve the very highest extraction rates. There's also a choice of motors, which can be positioned in a range of locations to reduce noise and free-up space.



Every Caple ceiling extractor uses our perimetric extraction system, which draws air in through narrow apertures around the full perimeter of the pan. It means higher air pressure, greater efficiency and less noise.

CREATING THE RIGHT ATMOSPHERE

You can also select just the right kind of lighting you want for your kitchen - from bright white to a soft, cosy, glow.

CONTROL AT YOUR FINGERTIPS

Our user-friendly remote control places power and lighting functions within easy reach. It also allows you to set the handy timer function, which automatically switches off the extractor after 10 minutes. When you leave your kitchen you know that any odours will be gone by the time you return.



CENTRE STAGE

We love the challenge of making functionality look stunning. Our hoods represent the epitome of contemporary design and technology.

Perfectly complementing any other Caple product, our ceiling hoods provide performance and styling like no other.



LED strip lighting, white glass finish and intelligent features ensure it has a place not only as a talking point in your kitchen, but an invaluable and practical addition.

MOTOR CHOICES



Some models have unique built-in motors, others will need to be purchased with a motor. To get the right power for you see our full range of motors on p.126-131.

CEILING HOOD WITH BUILT-IN MOTOR



PRODUCT CODE
CE1000

DIMENSIONS
w:1000mm

PERFORMANCE
Energy Class B
Max. extraction 757m³/h
Max. noise level 61dB[A]
Fluid dynamic efficiency A
Grease absorption F

FINISH AVAILABLE
White Glass with
Stainless Steel

FEATURES

- Motor included
- Remote control included
- Perimetrical extraction for reduced noise and increased pressure resulting in improved motor performance
- Can be fitted with motor exposed or recessed
- Suitable for recirculation of ducted installation
- 4 Speeds
- 2 x 15.5W LED strip lights [dimnable]
- Auto timer – switch-off after 10mins
- Aluminium grease filters
- Ducting spigot size 150mm

OPTIONAL EXTRAS

- Washable carbon filter [CAP59CF]

Visit caple.co.uk for full range

INSTALLATION

- Diagram [p.251]
- Venting Kits [p.158]

CEILING HOOD WITH BUILT-IN MOTOR



CE1122SS



CE1121WH

*Image showing recessed fitting option

PRODUCT CODE
Stainless steel CE1122SS
White CE1121WH

DIMENSIONS
w:1100mm

PERFORMANCE
Energy Class B
Max. extraction 753m³/h
Max. noise level 62dB[A]
Fluid dynamic efficiency A
Light efficiency E
Grease absorption F

FINISH AVAILABLE
Stainless Steel
White Glass

FEATURES

- Remote control included
- Perimetrical extraction for reduced noise and increased pressure resulting in improved motor performance
- 4 Speeds
- 2 x 18.5W LED strip lights with dimmer function
- Auto timer – switch-off after 10mins
- Aluminium grease filters
- Ducting spigot size 150mm
- Motor included

OPTIONAL EXTRAS

- Recirculation kit [CAP64CF]

Visit caple.co.uk for full range

INSTALLATION

- Diagram [p.251]
- Venting Kits [p.158]

CEILING HOOD



PRODUCT CODE
CE1101

DIMENSIONS
w:1100mm

PERFORMANCE
Energy Class A+ - C
For energy and performance see p.128-131

FINISH AVAILABLE
Stainless Steel

FEATURES

- Remote control included
- Perimetrical extraction for reduced noise and increased pressure resulting in improved motor performance

- 4 Speeds [inc. Boost function]
- 4 x 16W dichroic lights with dimmer
- Auto timer - switch off after 10mins
- Aluminium grease filters
- Required ducting size 150mm
- Ducted only installation
- Motor not included

MOTOR CHOICES

- Ceiling extractors will need to be purchased with a motor. For the full range please see p.126-131.

INSTALLATION

- Diagram [p.251]
- Venting Kits [p.158]

Venting choices

Ensure you purchase the correct venting for your Caple extractor. For the full range please see p.158-159

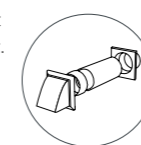

CEILING HOODS



CE902SS



CE902WH

PRODUCT CODE
Stainless Steel CE902SS
White CE902WH

DIMENSIONS
w:900mm

PERFORMANCE
Energy Class A+++ - B
For energy and performance see p.128-131

FINISH AVAILABLE
Stainless Steel
White Glass

FEATURES

- Remote control included
- Perimetrical extraction for reduced noise and increased pressure resulting in improved motor performance
- 4 Speeds [inc. Boost function]

- 2 x 6.5W LED light strips with dimmer function
- Aluminium grease filters
- Required ducting size 150mm
- Ducted only installation
- Motor not included

MOTOR CHOICES

- Ceiling extractors will need to be purchased with a motor. For the full range please see p.126-131.

INSTALLATION

- Diagram [p.251]
- Venting Kits [p.158]

EXTRACTION MOTOR OPTIONS



PRODUCT CODE
DDMEXT11

PERFORMANCE
e For performance
see p.128-131

FEATURES

- Motor for use with Caple downdraft extractors only [cannot be used with Caple ceiling hoods]
- For installation in cabinet fixing directly to the downdraft body
- Aluminium die-cast construction
- Required ducting size 150mm

INSTALLATION

- Diagram [p.251]
- Venting Kits [p.158]

PRODUCT CODE
DDMEXT21

PERFORMANCE
e For performance
ee p.128-131

FEATURES

- Motor for use with Caple downdraft or ceiling extractors
- For installation in ceiling cavity or floor space
- 7m long electrical connection cable [allowing motor installation up to 7m from the extractor]
- Aluminium die-cast construction
- Required ducting size 150mm
- Rigid ducting must be used

INSTALLATION

- Diagram [p.251]
- Venting Kits [p.158]

PRODUCT CODE
DDMEXT25

PERFORMANCE
e For performance
ee p.128-131

FEATURES

- Motor for use with Caple downdraft or ceiling extractors
- For installation in ceiling cavity or floor space
- 7m long electrical connection cable [allowing motor installation up to 7m from the extractor]
- Aluminium die-cast construction
- Required ducting size 150/200mm
- Rigid ducting must be used

INSTALLATION

- Diagram [p.251]
- Venting Kits [p.158]



PRODUCT CODE
DDMEXT28

PERFORMANCE
e For performance
ee p.128-131

FEATURES

- Motor for use with Caple downdraft extractors only [cannot be used with Caple ceiling hoods]
- For easy installation behind the plinth
- Aluminium die-cast construction
- Required ducting size 150mm
- Rigid ducting must be used
- **TO BE USED IN RECIRCULATION MODE ONLY [RECIRCULATION KIT REQUIRED, PG 128-131]**

INSTALLATION

- Diagram [p.251]

PRODUCT CODE
DDMEXT30

PERFORMANCE
e For performance
ee p.128-131

FEATURES

- Motor for use with Caple downdraft or ceiling extractors
- For installation on outside wall
- 7m long electrical connection cable [allowing motor installation up to 7m from the extractor]
- Stainless steel die-cast construction
- Required ducting size 150mm
- Rigid ducting must be used

INSTALLATION

- Diagram [p.251]
- Venting Kits [p.158]

PRODUCT CODE
DDMEXT40

PERFORMANCE
e For performance
ee p.128-131

FEATURES

- Motor for use with Caple downdraft or ceiling extractors
- For installation on outside wall
- 7m long electrical connection cable [allowing motor installation up to 7m from the extractor]
- Stainless steel die-cast construction
- Required ducting size 150/200mm
- Rigid ducting must be used

INSTALLATION

- Diagram [p.251]
- Venting Kits [p.158]

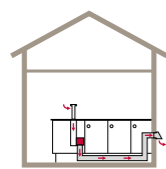

DDMEXT11 with downdraft

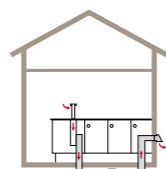

DDMEXT21 with downdraft

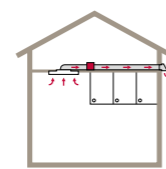

DDMEXT21 for ceiling

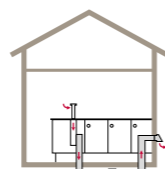

DDMEXT25 with downdraft

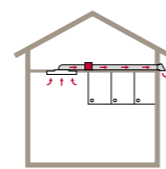

DDMEXT25 for ceiling

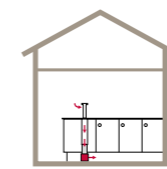

DDMEXT28 with downdraft

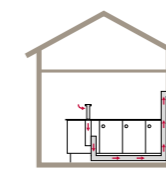

DDMEXT30 with downdraft

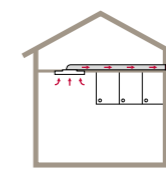

DDMEXT30 for ceiling

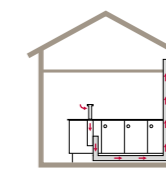

DDMEXT40 with downdraft

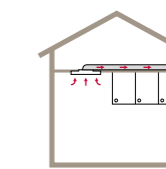

DDMEXT40 for ceiling

Due to the power and fitment of our external motors, rigid ducting must be used.

Due to the power and fitment of our external motors, rigid ducting must be used.



MOTOR PERFORMANCE

You can choose from an extensive range of Caple motors to go with your extractor.

To help you decide which motor suits your needs this table shows the motor combinations and the specific associated performance levels.

If you require further information please contact us directly.

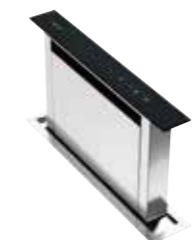

PRODUCT CODE	MOTOR CHOICE	DUCTING OUTLET SIZE [mm]
DOWNDRAFTS		
DD120BK	DDMEXT11	150
	DDMEXT21	150
	DDMEXT25	150
	DDMEXT25	200
	DDMEXT28	150
	DDMEXT30	150
	DDMEXT40	150
	DDMEXT40	200
DD911SS	DDMEXT11	150
DD911BK	DDMEXT21	150
DD911WH	DDMEXT25	150
	DDMEXT25	200
	DDMEXT28	150
	DDMEXT30	150
	DDMEXT40	150
	DDMEXT40	200
DD901BK	DDMEXT11	150
	DDMEXT21	150
	DDMEXT28	150
	DDMEXT30	150
DD606SS	DDMEXT11	150
DD606BK	DDMEXT21	150
	DDMEXT25	150
	DDMEXT25	200
	DDMEXT28	150
	DDMEXT30	150
	DDMEXT40	150
	DDMEXT40	200
DD522BK	DDMEXT21	150
	DDMEXT28	150
	DDMEXT30	150
	DDMEXT40	150
DD925CO	DDMEXT11	150
	DDMEXT21	150
	DDMEXT25	150
	DDMEXT28	150
	DDMEXT30	150

ENERGY CLASS	EXTRACTION RATE [m³/h]	FLUID DYNAMIC EFFICIENCY	LIGHT EFFICIENCY	GREASE ABSORPTION	NOISE LEVEL dB[A]	ANNUAL CONSUMPTION [kWh/yr]
e						
B	791	A	F	E	58	66
B	736	A	F	E	45	59
C	807	B	F	F	41	107
B	938	B	F	F	44	100
C	559	C	F	E	59	67
C	738	B	F	E	48	99
A	1310	A	F	F	55	121
A	1405	A	F	F	57	125
B	757	A	E	E	61	60
B	682	A	E	E	51	61
C	753	B	E	F	60	109
B	938	B	E	F	62	102
C	530	C	E	E	61	61
C	731	C	E	E	58	90
A	1240	A	E	F	58	116
A	1328	A	E	F	60	119
B	668	B	E	E	61	57
B	633	B	F	E	51	55
C	478	C	F	E	70	58
B	639	C	E	E	58	77
B	636	B	-	E	69	54
A	595	B	-	E	66	47
C	622	C	-	E	70	101
B	825	B	-	E	63	91
B	478	C	-	E	67	52
C	577	C	-	E	68	83
B	1110	A	-	E	64	130
B	1210	A	-	E	66	139
A	618	A	-	C	66	48
C	493	D	-	C	70	60
B	597	C	-	D	68	73
B	970	A	-	F	63	147
A	690	A	C	C	61	51
A	660	A	C	C	51	49
C	775	C	C	C	60	109
C	525	D	C	C	61	66
B	665	B	C	C	58	75

COOKING

128

129

MOTOR PERFORMANCE



MOTOR PERFORMANCE



PRODUCT CODE	MOTOR CHOICE	DUCTING OUTLET SIZE [mm]
DD931BK	DDMEXT11	150
	DDMEXT21	150
	DDMEXT25	150
	DDMEXT25	200
	DDMEXT28	150
	DDMEXT30	150
	DDMEXT40	150
	DDMEXT40	200
DD903BK	DDMEXT21	150
	DDMEXT28	150
	DDMEXT30	150
CEILING HOODS		
CE1101	DDMEXT21	150
	DDMEXT25	150
	DDMEXT25	200
	DDMEXT30	150
	DDMEXT40	150
	DDMEXT40	200
CE902SS & CE902WH	DDMEXT21	150
	DDMEXT25	150
	DDMEXT25	200
	DDMEXT30	150
	DDMEXT40	150
	DDMEXT40	200

ENERGY CLASS	EXTRACTION RATE [m³/h]	FLUID DYNAMIC EFFICIENCY	LIGHT EFFICIENCY	GREASE ABSORPTION	NOISE LEVEL dB[A]	ANNUAL CONSUMPTION [kWh/yr]
e						
A	757	A	A	E	61	53
B	682	B	A	E	51	60
C	753	B	A	F	60	103
B	938	B	A	F	62	96
C	520	C	A	E	61	52
C	731	C	A	E	58	83
A+	1240	A	A	F	58	109
A+	1328	A	A	F	60	113
A	600	B	/	C	66	47
B	484	C	/	C	70	52
B	582	C	/	D	68	74
C	725	B	F	F	46	107
C	869	B	F	F	44	138
B	938	A	F	F	48	109
C	773	B	F	F	55	130
A	1464	A	F	F	69	139
A+	1543	A	F	F	71	126
B	670	B	B	F	44	63
B	900	B	B	F	42	97
B	965	A	B	F	46	99
B	790	B	B	F	47	88
A	1490	A	B	F	67	102
A++	1575	A	B	F	69	89

COOKING

130

131

MOTOR PERFORMANCE



Island Hoods

High quality, highly efficient and intuitive our range of island hoods offer every kind of style to suit your kitchen.

POWER AND LIGHTING AT YOUR FINGERTIPS

Power and lighting adjustments at your fingertips with our user-friendly remote control. The handy timer function automatically switches off the extractor after 10 minutes, so you can leave your kitchen knowing any odours will have disappeared when you return - just some of the features from our fabulous island hood range.

CERAMICA

The Ceramica island hood with its incredibly eye-catching handmade ceramic body, features exquisite attention to detail and powerful extraction.



CR700

CR700WH

CR700SL

PRODUCT CODE

Copper	CR700
White	CR700WH
Silver	CR700SL

DIMENSIONS

↔ w:690mm

PERFORMANCE

e Max. Extraction 550m³/h
Max. Noise level 65dB[A]

FINISH AVAILABLE

	Copper
	White
	Silver

FEATURES

- Handmade ceramic body with stainless steel filter
- Remote control
- 4 Speeds
- 20W LED light
- Auto timer – switch-off after 10mins
- Stainless steel washable grease filter
- Recirculation only installation [supplied with washable recirculation kit]

OPTIONAL EXTRAS

- Replacement washable recirculation kit [CAP58CF]
- Visit caple.co.uk for full range

INSTALLATION

- Diagram [p.252]

Features

REMOTE CONTROL INCLUDED

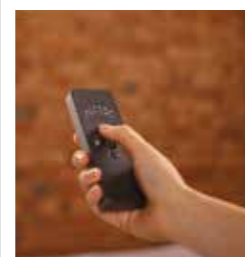

CERAMICA ELLIAS

The Ellias island hood is a beautiful addition to the Ceramica family. The iconic handmade ceramic hood has adopted a distinctive contoured exterior with all the power and efficiency you would expect from Caple extraction.



CR750CO

CR750WH

CR750SL

PRODUCT CODE

Copper	CR750CO
White	CR750WH
Silver	CR750SL

DIMENSIONS

↔ w:690mm

PERFORMANCE

e Max. Extraction 550m³/h
Max. Noise level 68dB[A]

FINISH AVAILABLE

	Copper
	White
	Silver

FEATURES

- Handmade ceramic body with stainless steel filter
- Remote control
- 4 Speeds
- 20W LED light
- Auto timer – switch-off after 10mins
- Stainless steel washable grease filter
- Recirculation only installation [supplied with washable recirculation kit]

OPTIONAL EXTRAS

- Replacement washable recirculation kit [CAP58CF]
- Visit caple.co.uk for full range

INSTALLATION

- Diagram [p.252]

Features

REMOTE CONTROL INCLUDED



ZALTO

The Zalto offers iconic styling and exceptional performance. You can choose from a copper, silver or black finish. Whatever your preference, this hood offers stand-out looks whilst integrating perfectly into your kitchen.



ZAL48CO



ZAL48SL



ZAL48BK

PRODUCT CODE

Copper ZAL48CO
Silver ZAL48SL
Black ZAL48BK

DIMENSIONS

↔ w:480mm

PERFORMANCE

e Max. extraction 550m³/h
Max. noise level 63dB[A]

FINISH AVAILABLE

Copper
 Silver
 Black

FEATURES

- Remote control included
- Painted stainless steel finish
- 4 Speeds
- 40W Neon light
- Auto timer – switch-off after 10mins
- Aluminium washable grease filter
- Recirculation only installation [supplied with washable recirculation kit]

OPTIONAL EXTRAS

- Replacement washable recirculation kit [CAP74CF]
- Visit cagle.co.uk for full range

INSTALLATION

- Diagram [p.252]

Features

REMOTE CONTROL INCLUDED



ISLAND HOODS



Plaza



Orbit

PRODUCT CODE

Pi402 Plaza
Oi363 Orbit

DIMENSIONS

↔ w:400mm Pi402
↔ w:362mm Oi362

PERFORMANCE

e Energy Class A
Fluid dynamic efficiency A
Light efficiency A
Grease absorption D
Annual Consumption [Pi402] 53kWh/yr
[Oi363] 44kWh/yr
Max. extraction 730m³/h
Max. noise level 64dB[A]

Features

REMOTE CONTROL INCLUDED



FINISH AVAILABLE

Stainless Steel

FEATURES

- Remote control included
- 4 Speeds [inc. Boost setting]
- 1 x 4W high intensity LED light
- Auto timer – switch-off after 10mins
- Aluminium grease filter
- Required ducting size 150mm
- Recirculation kit available

Pi402 OPTIONAL EXTRAS

- Recirculation kit [CAP39CF]
- Visit cagle.co.uk for full range

Oi362 OPTIONAL EXTRAS

- Recirculation kit [CAP38CF]
- Visit cagle.co.uk for full range

INSTALLATION

- Diagram [p.252]
- Venting Kits [p.158]

ISLAND HOOD



PRODUCT CODE

BXi911

DIMENSIONS

↔ w:900mm

PERFORMANCE

e Energy Class D
Fluid dynamic efficiency D
Light efficiency D
Grease absorption D
Annual Consumption 96kWh/yr
Max. extraction 605m³/h
Max. noise level 69dB[A]

FINISH AVAILABLE

Stainless Steel

Venting choices

Ensure you purchase the correct venting for your Cagle extractor. For the full range please see p.158-159

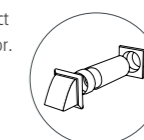

FEATURES

- Touch controls
- 3 Speeds
- 4 x 1.5W high intensity LED lights
- Aluminium grease filters
- Required ducting size 150mm
- Supplied with 2m length of semi-rigid ducting
- Recirculation kit available

OPTIONAL EXTRAS

- Recirculation kit [CAP61CF]
- Visit cagle.co.uk for full range

INSTALLATION

- Diagram [p.252]
- Venting Kits [p.158]



ISLAND HOOD

PRODUCT CODE
Zi922

DIMENSIONS
w:900mm

PERFORMANCE
e Energy Class B
 Fluid dynamic efficiency B
 Light efficiency A
 Grease absorption D
 Annual Consumption
 54kWh/yr
 Max. extraction 581m³/h
 Max. noise level 66dB[A]

FINISH AVAILABLE
 Stainless Steel with a Black
 Glass front panel

FEATURES
 - Illuminated LED touch controls
 front and back
 - 3 Speeds
 - Large LED light panel
 - Aluminium grease filters
 - Required ducting
 size 150mm 
 - Recirculation kit available

OPTIONAL EXTRAS
 - Recirculation kit [CAP61CF]
 Visit cagle.co.uk for full range

INSTALLATION
 - Diagram [p.253]
 - Venting Kits [p.158]



ISLAND HOODS



PRODUCT CODE
CGi921

DIMENSIONS
 w:900mm
 h:920-1240mm

PERFORMANCE
e Energy Class A
 Fluid dynamic efficiency A
 Light efficiency C
 Grease absorption D
 Annual Consumption
 42kWh/yr
 Max. extraction 617m³/h
 Max. noise level 68dB[A]

FINISH AVAILABLE
 Stainless Steel with curved
 Clear Glass

FEATURES
 - Touch controls
 - 3 Speeds
 - 4 x 1.5W high intensity
 LED lights
 - Aluminium grease filters
 - Required ducting
 size 150mm 
 - Supplied with 2m length of
 semi-rigid ducting
 - Recirculation kit available

OPTIONAL EXTRAS
 - Recirculation kit [CAP61CF]
 Visit cagle.co.uk for full range

INSTALLATION
 - Diagram [p.253]
 - Venting Kits [p.158]

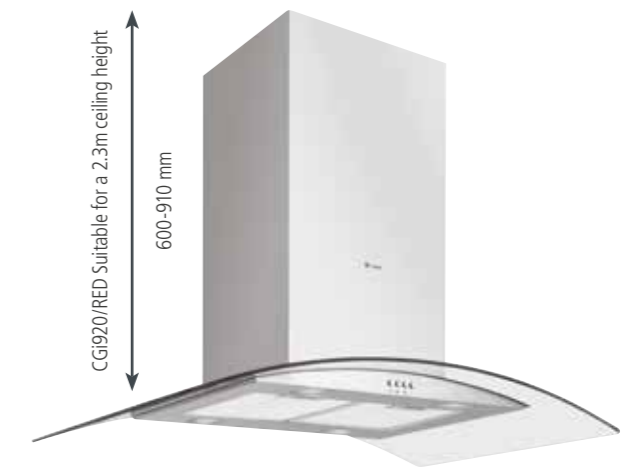

PRODUCT CODE
CGi920/RED
 [Reduced ceiling height]

DIMENSIONS
 w:900mm
 h:600-910mm

PERFORMANCE
e Energy Class D
 Fluid dynamic efficiency D
 Light efficiency C
 Grease absorption D
 Annual Consumption
 96kWh/yr
 Max. extraction 608m³/h
 Max. noise level 69dB[A]

FINISH AVAILABLE
 Stainless Steel with curved
 Clear Glass

FEATURES
 - Electronic controls
 - 3 Speeds
 - 4 x 1.5W high intensity
 LED lights
 - Aluminium grease filters
 - Required ducting
 size 150mm 
 - Supplied with 2m length
 of semi-rigid ducting
 - Recirculation kit available

OPTIONAL EXTRAS
 - Recirculation kit [CAP61CF]
 Visit cagle.co.uk for full range

INSTALLATION
 - Diagram [p.253]
 - Venting Kits [p.158]

Venting choices

Ensure you purchase the correct
 venting for your Cagle extractor.
 For the full range please see
 p.158-159

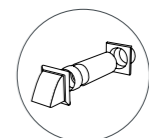



Wall Chimney Hoods

Our practical and stylish chimney hoods are sure to make a statement. Multi-functional and great to look at extraction will be a joy when you cook.

MOTUS TOUCH

Minimal, sleek styling and advanced engineering combine effortlessly to make an exceptional extractor. It slides smoothly into action, operated via subtle, elegant electronic touch controls.

PRODUCT CODE
MOT912

DIMENSIONS
w:900mm

PERFORMANCE

e Energy Class A+
Fluid Dynamic Efficiency A
Light Efficiency B
Grease Absorption D
Annual Consumption 46kWh/yr
Max. extraction 757m³/h
Max. noise level 62dB[A]

FINISH AVAILABLE

Black Glass with Stainless Steel

FEATURES

- Supplied with optional stainless steel flue

- Full touch controls with electronic display
- Mechanical automatic opening [dependent on speed setting]
- Perimetrical extraction for reduced noise and increased pressure resulting in improved motor performance
- 4 Speeds [inc. Boost setting]
- 10W LED strip light
- Auto timer switch-off after 10mins
- Aluminium washable grease filters
- Required ducting size 150mm 
- Recirculation kit available

OPTIONAL EXTRAS

- Recirculation kit [CAP52CF]
Visit caple.co.uk for full range

INSTALLATION

- Diagram [p.254]
- Venting Kits [p.158]



OMNIS

The ultra-modern, sleek black glass and slanted edges is ideal if you want to create a minimal and stylish look.



PRODUCT CODE

OM900
OM600

DIMENSIONS

w:900mm OM900
w:600mm OM600

PERFORMANCE

e Energy Class C
Fluid Dynamic Efficiency D
Light Efficiency B
Grease Absorption C [OM600]
B [OM900]
Annual Consumption 51kWh/yr
Max. extraction 456m³/h
Max. noise level 62dB[A]

FINISH AVAILABLE

Black glass

FEATURES

- Illuminated LED touch controls
- 3 Speeds
- 2 x 1.5W LED lights
- Aluminium grease filters
- Ducting spigot size 150mm 
- Recirculation kit available

OPTIONAL EXTRAS

- Recirculation kit [CAP61CF]
Visit caple.co.uk for full range

INSTALLATION

- Diagram [p.254]
- Venting Kits [p.158]

Venting choices

Ensure you purchase the correct venting for your Caple extractor. For the full range please see p.158-159

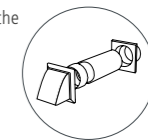

ELEGANT EFFICIENCY

Your Motus hood glides into action with touch control operation and an electric blue display.



STAGE 1

The whisper quiet perimetrical extraction system removes even the subtlest odours.

STAGE 2

The black glass front rises further to reveal the aluminium filters as the extraction level increases.

STAGE 3

It glides effortlessly into position to remove even those hard to shift cooking odours.

STAGE 4

Maximum extraction when you need it most. Still operating below an impressive 62dB[A].

SPIRIT

Choose from smooth black glass or go for stainless steel with smoked glass. What's more, this hood can also work in recirculation mode.



SP911SS

SP611SS

SP911BK

SP611BK

PRODUCT CODE

Stainless Steel	SP911SS
Black Glass	SP911BK
Stainless Steel	SP611SS
Black Glass	SP611BK

DIMENSIONS

	w:900mm	SP911SS
	w:900mm	SP911BK
	w:600mm	SP611SS
	w:600mm	SP611BK

PERFORMANCE

	Energy Class C
	Fluid Dynamic Efficiency D
	Light Efficiency D
	Grease Absorption D
	Annual Consumption 70kWh/yr
	Max. extraction 446m ³ /h
	Max. noise level 62dB[A]

FINISH AVAILABLE

- Stainless Steel with smoked glass panels
- Black Gloss with black glass panels

FEATURES

- Slider touch control
- Remote control included
- 3 Speeds
- 3.0 watt white LED light bar with 4 levels of brightness
- Auto timer
- Aluminium grease filter
- Required ducting size 150mm
- Recirculation kit available

OPTIONAL EXTRAS

- Recirculation kit [CAP24CF]
- Visit caple.co.uk for full range

INSTALLATION

- Diagram [p.254]
- Venting Kits [p.158]

Features

REMOTE CONTROL INCLUDED



ASTRO

Powerful and impressive, Astro offers a design that delivers performance and a touch of drama.



AS911BK

AS611BK

PRODUCT CODE

AS911BK
AS611BK

DIMENSIONS

	w:900mm	AS911BK
	w:600mm	AS611BK

PERFORMANCE

	Energy Class C
	Fluid Dynamic Efficiency A
	Light Efficiency D
	Grease Absorption D
	Annual Consumption 72kWh/yr
	Max. extraction 483m ³ /h
	Max. noise level 62dB[A]

FINISH AVAILABLE

- Black Glass with Stainless Steel

FEATURES

- Touch control
- 3 Speeds
- 4 x 1.5W LED lights
- Aluminium grease filter
- Required ducting size 150mm
- Supplied with optional stainless steel flue
- Recirculation kit available

OPTIONAL EXTRAS

- Recirculation kit [CAP55CF - 2 required]
- Visit caple.co.uk for full range

INSTALLATION

- Diagram [p.254]
- Venting Kits [p.158]

Features

FUNCTION AND POWER

This model features a sheer black glass front with a stylish stainless steel light bar to create the perfect mood lighting. Practical touch-controls and a choice of two sizes, ideal if you're looking for style and functionality.

VENTING CHOICES

Ensure you purchase the correct venting for your Caple extractor. For the full range please see p.158-159

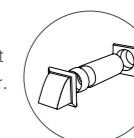

WALL CHIMNEY HOOD



PRODUCT CODE
ZZ801

DIMENSIONS
w:800mm

PERFORMANCE
Energy Class B
Fluid Dynamic Efficiency B
Light Efficiency A
Grease Absorption D
Annual Consumption
58kWh/yr
Max. extraction 604m³/h
Max. noise level 62dB[A]

FINISH AVAILABLE
Stainless Steel with
Black Glass

FEATURES
- Touch control
- 4 Speeds
- 2 x 6.5W LED light strips
- Auto timer
- Aluminium grease filter
- Required ducting size 150mm

OPTIONAL EXTRAS
- Recirculation kit [CAP47CF]
Visit caple.co.uk for full range

INSTALLATION
- Diagram [p.255]
- Venting Kits [p.158]

Venting choices

Ensure you purchase the correct venting for your Caple extractor. For the full range please see p.158-159

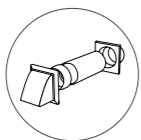

LUCIS WALL CHIMNEY HOOD



PRODUCT CODE
LUC600

DIMENSIONS
w:598mm

PERFORMANCE
Max. extraction 500m³/h
Max. noise level 55dB[A]

FINISH AVAILABLE
Black and White Glass with
Stainless Steel

FEATURES
- Supplied with optional stainless steel flue [not shown]
- Rotary control with electronic display
- Perimetrical extraction for reduced noise and increased pressure resulting in improved motor performance
- 4 Speeds
- 3 x 1W LED lights
- Auto timer switch-off after 10mins
- Aluminium washable grease filter
- Required ducting size 125mm
- Recirculation kit available

OPTIONAL EXTRAS
- Recirculation kit [CAP53CF]
Visit caple.co.uk for full range

INSTALLATION
- Diagram [p.255]
- Venting Kits [p.158]

Features

LED LIGHTING

For additional style and mood lighting 3 LED lights sit underneath the hood with a clever auto switch off timer.



ZODIAC WALL CHIMNEY HOODS

PRODUCT CODE
ZC922
ZC622

Annual Consumption
54kWh/yr
Max. extraction 570m³/h
Max. noise level 66dB[A]

DIMENSIONS
w:900mm ZC922
w:600mm ZC622

FINISH AVAILABLE
Stainless Steel with black
glass panel

ZC922 PERFORMANCE
Energy Class B
Fluid Dynamic Efficiency A
Light Efficiency A
Grease Absorption D

Annual Consumption
45kWh/yr
Max. extraction 587m³/h
Max. noise level 66dB[A]

ZC622 PERFORMANCE
Energy Class B
Fluid Dynamic Efficiency B
Light Efficiency A
Grease Absorption D

FEATURES
- Illuminated LED touch control
- 3 Speeds
- Large LED light panel
- Aluminium grease filters
- Required ducting size 150mm
- Recirculation kit available

OPTIONAL EXTRAS
- Recirculation kit [CAP61CF]
Visit caple.co.uk for full range

INSTALLATION
- Diagram [p.255]
- Venting Kits [p.158]



ZC922



ZC622



Classic Hoods

From bold statement pieces to discreet integrated models. Whatever you're looking for, we can help.

You'll find a near-endless choice of styles and functionality in the Classic range. Whichever you opt for, you can guarantee it will perform to the highest standards and keep your kitchen free from odours and grease, while powerful halogen or LED lights illuminate the cooking zone below.



WALL CHIMNEY HOODS



FGC920 FGC720 FGC620

PRODUCT CODE

FGC920
FGC720
FGC620

DIMENSIONS

↔ w:895mm FGC920
w:695mm FGC720
w:595mm FGC620

PERFORMANCE

e Energy Class D
Fluid Dynamic Efficiency D
Light Efficiency B
Grease Absorption C
Annual Consumption
60kWh/yr
Max. extraction 580m³/h
Max. noise level 68dB[A]

FINISH AVAILABLE

■ Stainless Steel with flat clear glass

FEATURES

- Push button controls
- 3 Speeds
- 2 x 1.5W high intensity LED lights
- Aluminium grease filter
- Required ducting size 150mm
- Supplied with 2m length of semi-rigid ducting
- Recirculation kit available

OPTIONAL EXTRAS

- Recirculation kit [CAP61CF]
- Visit caple.co.uk for full range

INSTALLATION

- Diagram [p.255]
- Venting Kits [p.158]

Features

FUNCTION & POWER

This model has a powerful maximum extraction rate of 580m³/h, perfect if you're looking for style, functionality and raw power.



WALL CHIMNEY HOODS



CGC910SS CGC710SS CGC610SS



CGC910BK CGC710BK CGC610BK

PRODUCT CODE

Stainless Steel CGC910SS
Black CGC910BK
Stainless Steel CGC710SS
Black CGC710BK
Stainless Steel CGC610SS
Black CGC610BK

DIMENSIONS

↔ w:895mm CGC910SS
w:895mm CGC910BK
w:695mm CGC710SS
w:695mm CGC710BK
w:595mm CGC610SS
w:595mm CGC610BK

PERFORMANCE

CGC910
e Energy Class D
Fluid Dynamic Efficiency F
Light Efficiency D
Grease Absorption B
Annual Consumption
60kWh/yr
Max. extraction 436m³/h
Max. noise level 60dB[A]

CGC710 and CGC610

e Energy Class D
Fluid Dynamic Efficiency F
Light Efficiency C
Grease Absorption G
Annual Consumption
59kWh/yr
Max. extraction 436m³/h
Max. noise level 60dB[A]

FINISH AVAILABLE

■ Stainless Steel with curved clear glass
■ Black with curved clear glass

FEATURES

- Push button controls
- 3 Speeds
- 2 x 1.5W high intensity LED lights
- Aluminium grease filters
- Required ducting size 150mm
- Supplied with 2m length of semi-rigid ducting
- Recirculation kit available

OPTIONAL EXTRAS

- Recirculation kit [CAP61CF]
- Visit caple.co.uk for full range

INSTALLATION

- Diagram [p.256]
- Venting Kits [p.158]

Venting choices

Ensure you purchase the correct venting for your Caple extractor. For the full range please see p.158-159

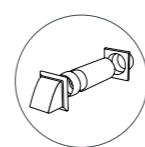

Features

SPLASHBACK

This unique splashback has been designed to fit perfectly with the curved canopy of the Caple CGC hoods and is available in black, pewter or stainless steel – see p162-163.





WALL CHIMNEY HOODS

PRODUCT CODE

BXC911
BXC611

DIMENSIONS

↔ w:900mm BXC911
w:600mm BXC611

PERFORMANCE

BXC911

e Energy Class C
Fluid Dynamic Efficiency D
Light Efficiency A
Grease Absorption D
Annual Consumption
86kWh/yr
Max. extraction 571m³/h
Max. noise level 76dB[A]

BXC611

e Energy Class D
Fluid Dynamic Efficiency F
Light Efficiency B
Grease Absorption C
Annual Consumption
61kWh/yr
Max. extraction 448m³/h
Max. noise level 59dB[A]

FINISH AVAILABLE

Stainless Steel

FEATURES

- Touch controls
- 3 Speeds
- 2 x 1.5W high intensity LED lights
- Aluminium grease filters
- Required ducting size 150mm 
- Recirculation kit available

OPTIONAL EXTRAS

- Recirculation kit [CAP61CF]
Visit caple.co.uk for full range

INSTALLATION

- Diagram [p.256]
- Venting Kits [p.158]

Features

FUNCTION & POWER

The seamlessly crafted stainless steel features easy-to-use touch controls to create a stylish focal point in your kitchen.

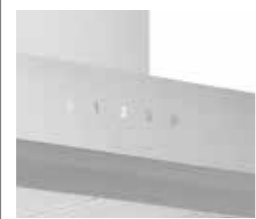

BXC911



BXC611

WALL CHIMNEY HOODS



CCH100



CCH900SS



CCH900BK



CCH700



CCH600SS



CCH600BK

PRODUCT CODE

Stainless Steel CCH100
Stainless Steel CCH900SS
Black CCH900BK
Stainless Steel CCH700
Stainless Steel CCH600SS
Black CCH600BK

FINISH AVAILABLE

Stainless Steel
Black

DIMENSIONS

↔ w:1000mm CCH100
w:900mm CCH900SS
w:900mm CCH900BK
w:700mm CCH700
w:600mm CCH600SS
w:600mm CCH600BK

PERFORMANCE

e Energy Class D
Fluid Dynamic Efficiency E
Light Efficiency G
Grease Absorption
- CCH100 & CCH900 - D
- CCH600 & CCH700 - C
Annual Consumption
74kWh/yr
Max. extraction 299m³/h
Max. noise level 63dB[A]

FEATURES

- Push button controls
- 3 Speeds
- 2 x 28W eco halogen lights
- Aluminium grease filters
- Required ducting size 150mm 
- Supplied with 2m length of semi-rigid ducting
- Recirculation kit available

OPTIONAL EXTRAS

- Recirculation kit [CAP60CF]
Visit caple.co.uk for full range

INSTALLATION

- Diagram [p.256]
- Venting Kits [p.158]

Features

FUNCTION & POWER

Simple in design, efficient in performance with a choice of 2 finishes to suit your kitchen.



VENTING CHOICES

Ensure you purchase the correct venting for your Caple extractor. For the full range please see p.158-159

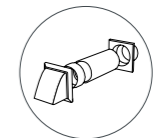

INTEGRATED HOOD



PRODUCT CODE
INCH

DIMENSIONS
w:600mm

PERFORMANCE
e Energy Class C
 Fluid Dynamic Efficiency E
 Light Efficiency B
 Grease Absorption D
 Annual Consumption
 37kWh/yr
 Max. extraction 285m³/h
 Max. noise level 52dB[A]

FINISH AVAILABLE
 Silver Grey

FEATURES
 - Slider control
 - 3 Speeds
 - 2 x 2W LED lights
 - Aluminium grease filters
 - Ducting spigot size 150mm
 - Recirculation kit available

OPTIONAL EXTRAS
 - Recirculation kit [CAP73CF]
 Visit caple.co.uk for full range

INSTALLATION
 - Diagram [p.256]
 - Venting Kits [p.158]

STORM BUILT-UNDER HOODS



ST853



ST523

PRODUCT CODE
ST853
ST523

DIMENSIONS
 w:850mm ST853
 w:520mm ST523

PERFORMANCE
ST853
e Energy Class A
 Fluid Dynamic Efficiency A
 Light Efficiency B
 Grease Absorption A
 Annual Consumption
 49kWh/yr
 Max. extraction 745m³/h
 Max. noise level 63dB[A]

ST523
e Energy Class A
 Fluid Dynamic Efficiency A
 Light Efficiency A
 Grease Absorption A
 Annual Consumption
 47kWh/yr
 Max. extraction 680m³/h
 Max. noise level 63dB[A]

FINISH AVAILABLE
 Stainless Steel

FEATURES
 - Electronic controls
 - 4 Speeds [inc. Boost]
 - Auto timer
 - 6W LED strip light
 - Stainless steel grease filters
 - Required ducting size 150mm
 - Recirculation kit available

ST853 OPTIONAL EXTRAS
 - Recirculation kit [CAP65CF - 2 required]
 Visit caple.co.uk for full range

ST523 OPTIONAL EXTRAS
 - Recirculation kit [CAP54CF - 2 required]
 Visit caple.co.uk for full range

INSTALLATION
 - Diagram [p.257]
 - Venting Kits [p.158]



TOUCH CONTROL BUILT-UNDER HOOD

PRODUCT CODE
TBU850

DIMENSIONS
 w:850mm

PERFORMANCE
e Energy Class A+
 Fluid Dynamic Efficiency A
 Light Efficiency B
 Grease Absorption A
 Annual Consumption
 46kWh/yr
 Max. extraction 772m³/h
 Max. noise level 63dB[A]

FINISH AVAILABLE
 Stainless Steel

FEATURES
 - Fold away glass panel with illuminated touch controls
 - 4 Speeds [inc. Boost]
 - Auto timer
 - 10.5W LED strip light
 - Stainless steel grease filters
 - Ducting spigot size 150mm
 - Recirculation kit available

OPTIONAL EXTRAS
 - Recirculation kit [CAP42CF - 2 required]
 Visit caple.co.uk for full range

INSTALLATION
 - Diagram [p.257]
 - Venting Kits [p.158]



Venting choices

Ensure you purchase the correct venting for your Caple extractor. For the full range please see p.158-159

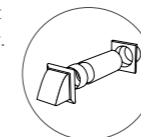



BUILT-UNDER HOOD



PRODUCT CODE
BU521

DIMENSIONS
w:520mm

PERFORMANCE
e Energy Class B
 Fluid Dynamic Efficiency B
 Light Efficiency A
 Grease Absorption B
 Annual Consumption
 58kWh/yr
 Max. extraction 604m³/h
 Max. noise level 70dB[A]

FINISH AVAILABLE
 Stainless Steel

FEATURES
 - Push button controls
 - 3 Speeds
 - 2 x 2.1w high intensity LED light
 - Aluminium grease filter
 - Required ducting size 150mm
 - Recirculation kit available

OPTIONAL EXTRAS
 - Recirculation kit [CAP66CF]
 Visit caple.co.uk for full range

INSTALLATION
 - Diagram [p.257]
 - Venting Kits [p.158]

BUILT-UNDER TELESCOPIC HOOD



PRODUCT CODE
TSCH600

DIMENSIONS
w:600mm

PERFORMANCE
e Energy Class D
 Fluid Dynamic Efficiency E
 Light Efficiency G
 Grease Absorption D
 Annual Consumption
 75kWh/yr
 Max. extraction 289m³/h
 Max. noise level 62dB[A]

FINISH AVAILABLE
 Stainless Steel fascia with
 Silver Grey body

FEATURES
 - Dual switch controls
 - 2 Speeds
 - 2 x 28W eco halogen lights
 - Aluminium grease filter
 - Required ducting size 120mm
 - Recirculation kit available

OPTIONAL EXTRAS
 - Recirculation kit [CAP60CF]
 Visit caple.co.uk for full range

INSTALLATION
 - Diagram [p.257]
 - Venting Kits [p.158]

BUILT-UNDER HOOD



PRODUCT CODE
BUCH

DIMENSIONS
w:520mm

PERFORMANCE
e Energy Class C
 Fluid Dynamic Efficiency E
 Light Efficiency B
 Grease Absorption D
 Annual Consumption
 37kWh/yr
 Max. extraction 286m³/h
 Max. noise level 52dB[A]

FINISH AVAILABLE
 Stainless Steel

FEATURES
 - Slider controls
 - 3 Speeds
 - 2 x 2W LED lights
 - Aluminium grease filters
 - Required ducting size 150mm
 - Recirculation kit available

OPTIONAL EXTRAS
 - Recirculation kit [CAP73CF]
 Visit caple.co.uk for full range

INSTALLATION
 - Diagram [p.257]
 - Venting Kits [p.158]

CONVENTIONAL HOOD



PRODUCT CODE
FSCHSS7

DIMENSIONS
w:600mm

PERFORMANCE
e Energy Class D
 Fluid Dynamic Efficiency F
 Light Efficiency G
 Grease Absorption E
 Annual Consumption
 74kWh/yr
 Max. extraction 194m³/h
 Max. noise level 64dB[A]

FINISH AVAILABLE
 Stainless Steel

FEATURES
 - Push button controls
 - 3 Speeds
 - 1 x 28W eco halogen light
 - Aluminium grease filters
 - Required ducting size 120mm
 - Recirculation kit available

OPTIONAL EXTRAS
 - Recirculation kit [CAP62CF]
 Visit caple.co.uk for full range

INSTALLATION
 - Diagram [p.257]
 - Venting Kits [p.158]

Venting choices

Ensure you purchase the correct venting for your Caple extractor. For the full range please see p.158-159

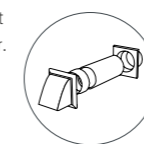



VENTING

To ensure you get the most out of your extraction we have the perfect venting solution to suit your needs.



100MM VENTING KIT

[CODE 202W]

1 Metre flexible venting kit



100MM VENTING KIT

[CODE 212W]

2 Metre venting kit



125MM VENTING KIT

[CODE 202-5W]

1 Metre flexible venting kit



125MM VENTING KIT

[CODE 227W]

3 Metre venting kit



150MM VENTING KIT

[CODE 202-6W]

1 Metre flexible venting kit

CHOOSING THE RIGHT VENTING

To ensure you have the correct venting for your chosen hood, please refer to the hood specification where the required diameter kit is listed.

EXTERNAL MOTORS

Due to the power and fitment of Caple external motors [DDMEXT11, DDMEXT21, DDMEXT25, DDMEXT28, DDMEXT30 and DDMEXT40, see p.126-127] you must use rigid ducting.

HIGH EFFICIENCY VENTING



125MM ELBOW BEND

[CODE 550GL]

- Suitable for 125mm flat channel ducting [204 x 60mm] Can be used with 227W and 515W



150MM ELBOW BEND

[CODE 950GL]

- Suitable for 150mm flat channel ducting [220 x 90mm] Can be used with 2653W, 2655W and 915W



150MM VENTING KIT

[CODE 2653WGL]

- For hoods with extraction over 500m³/h
- 3 metre venting kit



150MM VENTING KIT

[CODE 2655WGL]

- Suitable for use with downdraft hoods
- 3 metre ridged venting kit



Due to the profile of a duct bend, air travelling through it can become turbulent causing increased resistance and noise. As a consequence the cooker hood will need to work harder in order to meet the required airflow rates, therefore consuming more energy. This high efficiency 90° bend has been designed to allow a uniform flow of air through the section of ducting, reducing the resistance by up to 60% and lowering the air speed. All of which results in a quieter and more efficient system.

- Smoothly channels air through the duct bend in a uniform flow
- Reduced duct resistance by up to 60% to lower the systems pressure drop and overall energy usage
- Reduced air speed through the bend to reduce noise
- Performance has been tested by the Building Research Establishment [BRE]

The diagram illustrates the improvement of air flow when using 550GL or 950GL ducting

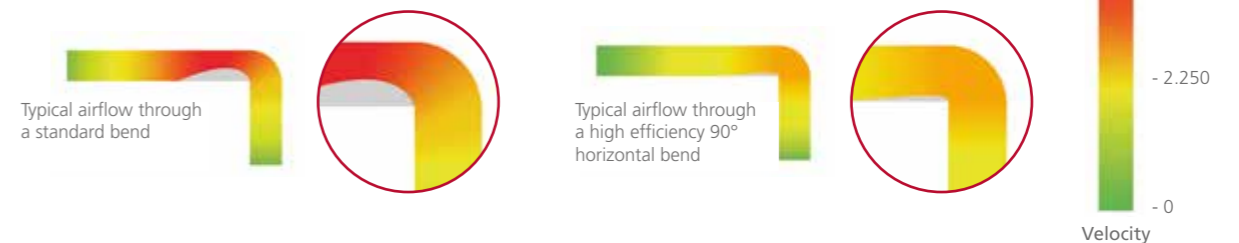



Splashbacks

The perfect finishing touch.

COOKING

160

161

SPLASHBACKS

TOUGHENED GLASS SPLASHBACK



PRODUCT CODE

TSB1000**
TSB900**
TSB600**

[Available in Black and pewter only]

DIMENSIONS

TSB1000	w:1000mm
TSB900	w:900mm
TSB600	w:600mm
	h:750mm*
	d:5mm*

FEATURES

- 10 Colours available
- Will not mark with fingerprints
- Adhesive backed for quick and easy DIY installation [no unsightly fixing screws]
- Toughened glass
- Conforms to BS EN12150:1 British Safety Standards
- Hygienic
- Opaque colour finish
- Can be applied to all flat non-porous, clean surfaces

CURVED TOUGHENED GLASS SPLASHBACK



PRODUCT CODE

TSBCURVE900**
TSBCURVE700**
TSBCURVE600**

DIMENSIONS

TSBCURVE900**	w:895mm
	[Fits CGC910 pg.151]
TSBCURVE700**	w:695mm
	[Fits CGC710 pg.151]
TSBCURVE600**	w:595mm
	h:750mm*
	d:5mm*
	[Fits CGC610 pg.151]

FEATURES

- 2 Colours available
- Fits Caple CGC hoods [p.151]
- Will not mark with fingerprints
- Adhesive backed for quick and easy DIY installation [no unsightly fixing screws]
- Toughened glass
- Conforms to BS EN12150:1 British Safety Standards
- Hygienic
- Opaque colour finish
- Can be applied to all flat non-porous, clean surfaces



*Applicable to all widths
For chosen colour option, replace ** with colour code – see swatches above.



*Applicable to all widths
For chosen colour option, replace ** with colour code – see swatches above.

Features

SAFE & EASY TO INSTALL

All Caple glass splashbacks are adhesive-backed. This stops them shattering and allows fitting to any clean, non-porous surface. All our glass products meet British Safety Standards and are made from toughened glass.



STAINLESS STEEL SPLASHBACK



PRODUCT CODE

CSB1006
CSB906
CSB706
CSB606

DIMENSIONS

CSB1006	w:1000mm
CSB906	w:900mm
CSB706	w:700mm
CSB606	w:600mm
	h:750mm*
	d:10.5mm*



Stainless Steel

*Applicable to all widths

CURVED STAINLESS STEEL SPLASHBACK



PRODUCT CODE

CSBCURVE905
CSBCURVE705
CSBCURVE605

DIMENSIONS

CSBCURVE905	w:900mm
	[Fits CGC910 pg.151]
CSBCURVE705	w:700mm
	[Fits CGC710 pg.151]
CSBCURVE605	w:600mm
	h:750mm*
	d:10.5mm*
	[Fits CGC610 pg.151]



Stainless Steel

*Applicable to all widths

COOLING

Professional Refrigeration	170
Freestanding Refrigeration	178
Integrated Refrigeration	180
Wine Cabinets	191





Refrigeration

Chill it, freeze it, love it.

Whether you want a discreet space-saving under-counter fridge or something more spacious, you'll find it right here.



Whatever you want, that's cool.

We've one for every kind of kitchen, big or small.
Different colours, different finishes, different sizes
and plenty of functionality.

PROFESSIONAL

The CAFF60 has a massive 820L capacity in six compartments, as well as three separate temperature zones - one freezer and two fridge zones. Each of which can be set to a different temperature. It can be built-in or used as a freestanding appliance.



FRENCH DOOR

This large, freestanding fridge freezer has two doors on the top for the fridge and drawers underneath for the freezer, great for storing large items.



SIDE-BY-SIDE

Big on looks and big on capacity. Available in black or stainless steel some side-by-side fridge freezers can also be plumbed in for a constant supply of cold filtered water and ice.



70/30 FREESTANDING

This is the perfect option when space is key. This stacked refrigeration solution allows you to keep that extra floor space with the impressive styling of freestanding refrigeration.



INTEGRATED

Our fridge freezer combinations or compact under-counter and in-column products can be hidden behind furniture doors. Choose fridges and freezers in different sizes and combinations depending on the space available and where you want to put them in your kitchen.





Professional Cooling Centre

Made from stainless steel both inside and out, the CAFF60 can be installed built-in or used as a freestanding fridge freezer with the addition of a pair of optional side panels [PANCAFF60].

PRODUCT CODE

CAFF60

DIMENSIONS

h:2129mm
w:1214mm
d:724.7mm
[inc. door - excl. handle]
d:778.7mm
[inc. door and handle]

PERFORMANCE

e Energy Class A++
Energy consumption
435kWh/yr
Max. noise level 48dB[A]
13kg/24hrs freezing
capacity

FINISH AVAILABLE

Stainless steel

FEATURES

- Argon filled triple glazed door
- Metal handles
- Plumbed internal automatic ice maker
- Filtered water supply for ice maker
- Electronic touch control with digital display
- 3 temperature zones
- Each fridge zone can be turned off independently
- Dual refrigeration system with 2 compressors and 3 evaporators
- 4 Star 216 litres, 2 star 31 litres
- Auto defrost
- Frost-free
- Super freeze and super cool functions
- Sabbath mode
- Open door alarm
- Forced air flow design
- Vegi-fresh compartment to keep vegetables fresh for longer

- Ambient humidity sensor for optimum performance
- Time and date display
- 100% CFC / HFC free
- Enhanced LED lighting through illuminated shelf supports
- Front access to levelling
- Can be installed built-in or freestanding with optional side panels [PANCAFF60]
- Climate class SN/T

DESIGN

- Stainless steel exterior and interior

STORAGE

- 6 Safety glass shelves
- 1 Sliding bottle tray
- 2 Freezer drawers
- 1 Crisper drawer
- 1 Ice compartment with ice maker
- 1 Glass marinating tray

CAPACITY

- 29 Cu ft/820 Litre total net capacity
- 25.2 Cu ft/713 Litre total gross capacity
- 16.5 Cu ft/466 Litre fridge net capacity
- 8.7 Cu ft/247 Litre freezer net capacity

OPTIONAL EXTRAS

- Pair of side panels for freestanding installation [PANCAFF60]
 - Replacement water filter [FILTER/CAFF60]
- Visit cable.co.uk for full range

INSTALLATION

- Diagram [p.258]

FEATURE RICH DESIGN

An argon filled triple glazed fridge compartment door allows you to see instantly what is in the fridge, which is further enhanced by subtle interior lights and illuminated shelf supports.

Supersized, super efficient and super stylish, the CAFF60, if your lucky enough to have the space in your kitchen, has everything you'd ever want in a large modern fridge freezer.

FREEZER AND FRIDGE ZONES

The CAFF60 has three separate temperature zones; one freezer and two fridge zones. The fridge zones are split into two. One behind the glazed door and the other one made up of the two fridge drawers directly below. All three zones can have different temperatures depending on your preference. The top fridge drawer also houses a veg-fresh compartment which is used to keep vegetables fresh for longer.

ELECTRONIC TOUCH CONTROLS

Each of the temperature zones can be controlled using the electronic touch control digital display. Other functions including date, time and a Sabbath mode can be easily accessed from this display panel too.

AUTOMATIC ICE MAKER

Convenience and capacity are very important when a fridge freezer like the CAFF60 is considered. Having a massive 820 litre total net capacity and the convenience of a filtered water ice maker, easily meets both requirements.

LED SHELF LIGHTING

Each shelf is enhanced by LED lighting acting as the shelf support. Not only does it give a dramatic look, it also ensures you can see exactly what your looking for.



PANCAFF60 Side panel



French Door Fridge Freezer

Convenience, additional storage and ease of use are the benefits of a French door fridge freezer compared to other types of refrigeration. Available in stainless steel with an 'A+' energy rating, the CAFF41 is an efficient, modern, family friendly appliance that looks great too.

DOUBLE UP

Two freezer drawers gives you easy access to your food and with the capacity of 167L, the CAFF41 can freeze all your tasty treats until you need them.

FULL ILLUMINATION

The stylish backlight takes centre stage illuminating the entire fridge from top to bottom ensuring you can see all your fridge's contents quickly and easily.

STEEL TRIMMED INTERIOR

Glass shelves with deluxe steel trims to catch any spills.



PRODUCT CODE
CAFF41

DIMENSIONS

h:1850mm
w:910mm
d:763mm
[inc. door - excl. handle]
d:812mm
[inc. door and handle]

PERFORMANCE

e Energy Class A+
Energy consumption
473kWh/yr
Max. noise level 45dB
Freezing capacity
20kg/24hrs

FINISH AVAILABLE

Stainless Steel

FEATURES

- Super freeze and super cool functions
- Electronic touch control with LED display
- 4 Star freezer
- Frost-free
- High temperature alarm
- Open door alarm
- Holiday mode
- Eco mode
- Drink chilling alarm
- Multi-air flow design in fridge and freezer compartments
- Self closing meat chiller compartment
- Child safety lock
- 100% CFC / HFC free
- Enhanced energy saving LED lighting
- Climate class T/N

DESIGN

- Stainless steel doors with grey cabinet
- Metal handles
- Steel trimmed interior

STORAGE

- 2 Spill-capture adjustable glass shelves
- 1 Spill-proof shelf crisper lid
- 2 Salad crispers
- 1 Meat chiller compartment
- 2 Covered dairy compartments
- 6 Door storage racks
- 2 Freezer drawers, 3 compartments
- Ice cube tray
- Egg storage tray

CAPACITY

- 557 Litre total net capacity
- 653 Litre total gross capacity
- 390 Litre fridge net capacity
- 167 Litre freezer net capacity

INSTALLATION

- Diagram [p.259]



Side-by-Side Fridge Freezers

A big family or big on entertaining at home? Either way a side-by-side fridge freezer is ideal. They are available with or without ice and water, come in black or stainless steel and have an A+ energy rating.

ICE AND WATER?

Choose between crushed or cubed ice. Chilled, filtered water is also available at the touch of a button on our CAFF207 models that can be plumbed directly in to your kitchen.

INTERNAL LED LIGHTING & TOUCH CONTROLS

Bold, well positioned LED lighting illuminate the interior of the fridge for excellent visibility while the touch controls provide quick access to all the handy functions.

WATER FILTERS

Fresh, great tasting filtered water supplied at the touch of a button. It improves the taste and odour by reducing chlorine, heavy metals and other sediments found in your tap water supply. It is located at the rear of the fridge compartment to allow easy access and it is quick to change with its simple, twist fit installation.



SIDE-BY-SIDE FRIDGE FREEZER



PRODUCT CODE

CAFF27

DIMENSIONS

h:1751mm
w:922mm
d:686mm

PERFORMANCE

Energy Class A+
Energy consumption
395kWh/yr
Max. noise level 45dB
Freezing capacity
12kg/24 hrs

FINISH AVAILABLE

Stainless Steel

FEATURES

- Recessed handles
- Electronic touch control with LED display
- 4 Star
- Auto defrost
- Frost-free
- Super freeze
- Open door alarm
- Child lock
- 100% CFC/HFC free
- Enhanced LED lighting
- Climate class SN-T

STORAGE

- 5 Spill-capture adjustable glass shelves
- 2 Freezer drawers
- 2 Crispers
- 8 Door storage racks

CAPACITY

- 17.02 Cu ft/482 Litre total net capacity
- 18.96 Cu ft/537 Litre total gross capacity
- 11.30 Cu ft/320 Litre fridge net capacity
- 5.72 Cu ft/162 Litre freezer net capacity

INSTALLATION

- Diagram [p.260]

SIDE-BY-SIDE FRIDGE FREEZER



PRODUCT CODE

CAFF23

DIMENSIONS

h:1751mm
w:922mm
d:700mm
[inc. door - excl. handle]
d:751mm
[inc. door and handle]

PERFORMANCE

e Energy Class A+
Energy consumption
456kWh/yr
Max. noise level 45dB
Freezing capacity
15kg/24 hrs

FINISH AVAILABLE

Stainless Steel

FEATURES

- Super freeze and super cool functions
- Electronic touch control with LED display
- 4 Star freezer [2 star in door storage]
- Auto defrost
- Frost-free
- High temperature alarm
- Open door alarm
- Multi air flow system
- Child safety lock
- 100% CFC/HFC free
- Internal LED lights

DESIGN

- Stainless steel doors with a grey cabinet
- Metal curved handles

STORAGE

- 6 Spill-capture adjustable glass shelves
- 1 Spill-proof crisper lid
- 2 Salad crispers
- 1 Covered dairy compartment
- 9 Door storage racks
- 2 Freezer drawers

CAPACITY

- 20.55 Cu ft/582 Litre total net capacity
- 22.25 Cu ft/630 Litre total gross capacity
- 13.21 Cu ft/374 Litre fridge net capacity
- 7.35 Cu ft/208 Litre freezer net capacity

INSTALLATION

- Diagram [p.260]

SIDE-BY-SIDE FRIDGE FREEZERS



CAFF207SS

PRODUCT CODE

Stainless Steel CAFF207SS
Black CAFF207BK

DIMENSIONS

h:1751mm
w:923mm
d:700mm
[inc. door - excl. handle]
d:770mm
[inc. door and handle]

PERFORMANCE

e Energy Class A+
Energy consumption
420kWh/yr
Max. noise level 45dB
Freezing capacity
12kg/24hrs

FINISH AVAILABLE

Stainless Steel
Black

FEATURES

- In door ice and water dispenser
- Cubed and crushed ice
- Electronic control with LED display
- 4 Star [2 star in door storage]
- Auto defrost
- Frost-free
- Super freeze and super cool functions
- High temperature alarm
- Open door alarm
- Multi-air flow design
- Easyfit water filter cartridge located in the fridge compartment
- Child lock
- 100% CFC / HFC free



CAFF207BK

- Enhanced LED lighting
- Climate class SN-N-ST-T

DESIGN

- Stainless steel doors with a grey cabinet or black doors with a black cabinet
- Metal curved handles

STORAGE

- 5 Spill-capture adjustable glass shelves
- 2 Crispers
- 8 Door storage racks
- 1 Dairy compartment
- 2 Freezer drawers

CAPACITY

- 19.42 Cu ft/550 Litre total net capacity
- 22.25 Cu ft/630 Litre total gross capacity
- 12.85 Cu ft/364 Litre fridge net capacity
- 6.57 Cu ft/186 Litre freezer net capacity

OPTIONAL EXTRAS

- Replacement water filter [FILTER/CAFF205]
- Visit caple.co.uk for full range

INSTALLATION

- Diagram [p.260]



70/30 Freestanding Refrigeration

DELUXE STAINLESS STEEL TRIM

Glass shelves with deluxe steel trims to catch any spills.

TOUCH CONTROLS

Easily control the temperature of the fridge and freezer from the touch control LED panel.

FRESH AIR FLOW TECHNOLOGY

The fan positioned at the top of the fridge circulates the cool air for even distribution keeping your food at the perfect temperature. Help preserve fresh foods for longer by adjusting the humidity in the crisper compartments.



FREESTANDING 70/30 FRIDGE FREEZER

PRODUCT CODE
RFF730

DIMENSIONS

h:1860mm
w: 595mm
d:650mm
[inc. door - excl. handle]

PERFORMANCE

e Energy Class A++
Energy consumption
263kWh/yr
Max. noise level 42dB [A]

FINISH AVAILABLE

Stainless Steel

GENERAL FEATURES

- Electronic touch control
- Independently electronic temperature control for fridge and freezer

- Energy saving display off option
- Easy to use control panel
- Right hand hinged door*
- Interior LED light
- Child lock
- Holiday mode
- Eco mode
- Feature metal handles
- High temperature alarm
- 100% CFC / HFC free
- Climate class T/SN

Fridge

- Auto defrost
- Super cool
- Fan cooled
- Humidity controlled fruit and veg drawer
- Chiller drawer for meat and fish
- Wine rack

Freezer

- Frost free
- Super freeze
- Drink cooling mode
- Safety stop drawers
- Freezing capacity 12kg/24hrs

STORAGE

- 2 Adjustable glass shelves
- 1 Glass cover shelf
- 1 Salad crisper
- 1 Humidity controlled drawer
- 1 Wine rack
- 3 Plastic door storage compartments
- 1 Egg tray
- 3 Freezer drawers
- 1 ice cube tray

CAPACITY

- 324 Litre total net capacity
- 341 Litre total gross capacity
- 94 Litre net freezer capacity
- 230 Litre net fridge capacity

INSTALLATION

- Diagram [p.260]

* The door is supplied RH hinged, it can be reversed. Please consult a qualified installation expert to reverse door configuration.



Integrated Refrigeration

Choose from tall column fridge or freezer combinations or compact under-counter models. How about an entirely separate fridge and freezer located in different spots around the kitchen? There are also tall all-in-one models that fit neatly into a single space.

Whatever you decide, it's reassuring to know that all of Caple's integrated refrigeration appliances have an A++ or A+ energy rating.

GLASS SHELVES

Some with deluxe steel trims to catch any spills.

WINE RACK OPTION

You can add a chrome wine rack that slots in like a shelf and holds four 750ml bottles.

FROST-FREE

No more laborious defrosting with a scraper. Our frost-free system works by heating up an element for a short time, which melts the ice and prevents build-up. Keeping a freezer ice-free means food stays fresher for longer. Freezing food is also much quicker, preserving as many nutrients as possible and freeing up much needed storage space.

SUPER FREEZE

Some models have Super Freeze, which speeds up freezing time and optimises performance.



The RiL1795 fridge and RiF1795 freezer have been designed with modern living in mind. The matching, in-column fridge and freezer are hidden behind your cabinet doors for an ultra neat finish in a contemporary or classic kitchen.

FULLY ADJUSTABLE SHELF

Key features in the A++ rated RiL1795 fridge include a fully adjustable shelf in the door for true flexibility in your cooling appliance.

ENHANCED LIGHTING

LED strip lighting across the top and down each side of the fridge for a stylish, practical finish.

CAPLE FRESH

Caple Fresh technology eliminates ethylene gas [a by-product of fresh foods] inside the vegetable drawer, therefore enabling your fresh food to last for longer. Caple's cool airflow system also ensures cold air will flow to every level for even chilling.



70/30 FRIDGE FREEZER – FROST-FREE



Ri737

70/30 FRIDGE FREEZER



Ri735

PRODUCT CODE

Ri737
Ri735

DIMENSIONS

h:1776mm

PERFORMANCE

e Energy Class A+
Energy consumption 281kWh/yr [Ri737]
Energy consumption 286kWh/yr [Ri735]
Max. noise level 39dB[A]
3kg/24hrs freezing capacity [Ri737]
3.5kg/24hrs freezing capacity [Ri735]

FINISH AVAILABLE

White

GENERAL FEATURES

- Mechanically controlled
- 100% CFC/HFC free
- Sliding door installation
- Reversible doors

Fridge

- Auto defrost
- Adjustable thermostat
- LED Interior light

Freezer

- 4 Star

DESIGN

- Transparent plastic drawers and compartments

STORAGE

- 4 Adjustable glass shelves
- 1 Glass crisper cover shelf
- 2 Salad crispers
- 4 Plastic door storage compartments
- 1 Egg tray
- 3 Freezer drawers
- 1 Ice cube tray

Ri737 UNIQUE FEATURES

Fridge

- Deluxe steel trimmed interior

Freezer

- Frost-free

Capacity

- 246 Litre total net capacity
- 251 Litre total gross capacity
- 190 Litre fridge net capacity
- 56 Litre freezer net capacity

Ri735 UNIQUE FEATURES

Freezer

- Manual defrost

Capacity

- 260 Litre total net capacity
- 272 Litre total gross capacity
- 190 Litre fridge net capacity
- 70 Litre freezer net capacity

INSTALLATION

- Diagram [p.261]

50/50 FRIDGE FREEZER – FROST-FREE



Ri558

50/50 FRIDGE FREEZER



Ri556

PRODUCT CODE

Ri558
Ri556

DIMENSIONS

h:1776mm

PERFORMANCE

e Energy Class A+
Energy consumption 297kWh/yr [Ri558]
Energy consumption 281kWh/yr [Ri556]
Max. noise level 39dB[A]
4.5kg/24hrs freezing capacity

FINISH AVAILABLE

White

GENERAL FEATURES

- Mechanically controlled
- 100% CFC/HFC free
- Reversible doors
- Sliding door installation

Fridge

- Auto defrost
- Adjustable thermostat
- LED Interior light

Freezer

- 4 Star

DESIGN

- Transparent plastic drawers and compartments

STORAGE

- 3 Adjustable glass shelves
- 1 Glass crisper cover shelf
- 2 Salad crispers
- 3 Plastic door storage compartments
- 1 Egg tray
- 4 Freezer drawers
- 1 Ice cube tray

Ri558 UNIQUE FEATURES

Fridge

- Deluxe steel trimmed interior

Freezer

- Frost free

Capacity

- 232 Litre total net capacity
- 241 Litre total gross capacity
- 154 Litre fridge net capacity
- 78 Litre freezer net capacity

Ri556 UNIQUE FEATURES

Freezer

- Manual defrost

Capacity

- 244 Litre total net capacity
- 256 Litre total gross capacity
- 154 Litre fridge net capacity
- 90 Litre freezer net capacity

INSTALLATION

- Diagram [p.261]



IN-COLUMN LARDER FRIDGE



PRODUCT CODE

RiL1795

DIMENSIONS

h:1770mm

PERFORMANCE

e Energy class A++
Energy consumption
111kWh/yr
Max. noise 39dB [A]

FINISH AVAILABLE

White

FEATURES

- Matches RIF1795 freezer
- Top and side LED strip lights
- Electronic controls
- Adjustable thermostat
- Auto defrost
- Super cooling mode
- Caple cool air-flow system
- Caple fresh
- Humidity controlled drawer
- Easy adjustable door balcony
- 100% CFC/HFC free
- Reversible door
- Sliding door installation

DESIGN

- Deluxe steel trimmed interior
- Transparent plastic drawers and compartments

STORAGE

- 4 Standard door storage compartments
- 1 Easy adjustable door compartment
- 2 Drawer compartments [1 with humidity controls for fruit and vegetable storage]
- 1 bottle rack
- 4 Removable glass shelves
- 1 Glass drawer cover shelf
- 1 Egg tray

CAPACITY

- 300 Litre total net capacity
- 303 Litre total gross capacity

INSTALLATION

- Diagram [p.262]

Features

FRUIT & VEGETABLE PRESERVATION

The new Caple Fresh preservation technology inside the crisper drawer, ensures that your fruit and vegetables stay fresher and tastier for longer. This innovative new system helps to eliminate the natural gases that are produced during the ripening and ageing process, preserving them for longer. Also, the Caple Fresh preserver does not need to be replaced. It can be regenerated by exposing it to sunlight for one day a year.



IN-COLUMN FREEZER - FROST FREE



PRODUCT CODE

RiF1795

DIMENSIONS

h:1770mm

PERFORMANCE

e Energy class A+
Energy consumption
297kWh/yr
Max. noise 41dB [A]
15kg / 24hr freezing capacity

FINISH AVAILABLE

White

GENERAL FEATURES

- Top LED strip light
- Electronic controls
- Adjustable thermostat
- Frost free
- Twist Ice cube maker

- Super Freeze mode
- 4 star
- 100% CFC/HFC free
- Reversible door
- Sliding door installation

DESIGN

- Deluxe steel trimmed interior
- Transparent plastic drawers

STORAGE

- 6 Drawers
- 2 flip down door compartments
- 1 Ice cube tray
- 1 Twist ice cube maker

CAPACITY

- 197 Litre total net capacity
- 221 Litre total gross capacity

INSTALLATION

- Diagram [p.262]

Features

FROST-FREE

No more laborious defrosting with a scraper. Our frost-free system works by heating up an element for a short time, which melts the ice and prevents build-up. Keeping a freezer ice-free means food stays fresher for longer. Freezing food is also much quicker, preserving as many nutrients as possible and freeing up much needed storage space.

LED LIGHTING & ELECTRONIC CONTROLS

Strip LED lighting adds a modern feel, while electronic controls are precise and easy to use.



TWIST ICE CUBE MAKER

The new twist ice cube maker is a convenient way to make ice, with the added benefits of easy removal for cleaning for those times when you need the extra space.



IN-COLUMN LARDER FRIDGE



PRODUCT CODE
RiL124

DESIGN
- Deluxe steel trimmed interior
- Transparent plastic drawer and compartments

DIMENSIONS
↔ h:1220mm

PERFORMANCE
e Energy Class A+
Energy consumption
127kWh/yr
Max. noise level 41dB[A]

FINISH AVAILABLE
 White

FEATURES
- Matches RiF123 freezer
- Mechanically controlled
- Auto defrost
- Adjustable thermostat
- Interior LED light
- Sliding door installation
- Reversible door

STORAGE
- 4 Removable glass shelves
- 1 Glass crisper cover shelf
- 1 Salad crisper
- 3 Plastic door storage compartments
- 1 Egg tray

CAPACITY
- 206 Litre total net capacity
- 208 Litre total gross capacity

INSTALLATION
- Diagram [p.262]

IN-COLUMN FREEZER



PRODUCT CODE
RiF123

DESIGN
- Transparent blue plastic drawers

DIMENSIONS
↔ h:1220mm

PERFORMANCE
e Energy Class A+
Energy consumption
215kWh/yr
Max. noise level 41dB[A]
6.5kg/24hrs freezing capacity

FINISH AVAILABLE
 White

FEATURES
- Matches RiL124 larder fridge
- Super freeze function
- Mechanically controlled
- 4 Star
- Manual defrost
- Adjustable thermostat
- Temperature alarm
- 100% CFC/HFC free
- Sliding door installation
- Reversible door

STORAGE
- 5 Drawers
- 1 Ice cube tray

CAPACITY
- 143 Litre total net capacity
- 145 Litre total gross capacity

INSTALLATION
- Diagram [p.262]

IN-COLUMN LARDER FRIDGE



PRODUCT CODE
RiL891

DESIGN
- Deluxe steel trimmed interior
- Transparent plastic drawer and compartments

DIMENSIONS
↔ h:880mm

PERFORMANCE
e Energy Class A+
Energy consumption
120kWh/yr
Max. noise level 41dB[A]

FINISH AVAILABLE
 White

FEATURES
- Matches RiF89 freezer
- Mechanically controlled
- Auto defrost
- Adjustable thermostat
- Interior light
- Sliding door installation
- Reversible door

STORAGE
- 3 Removable glass shelves
- 1 Glass crisper cover shelf
- 1 Salad crisper
- 3 Plastic door storage compartments
- 1 Egg tray

CAPACITY
- 142 Litre total net capacity
- 144 Litre total gross capacity

INSTALLATION
- Diagram [p.262]

IN-COLUMN FREEZER



PRODUCT CODE
RiF89

DESIGN
- Transparent blue plastic drawers

DIMENSIONS
↔ h:880mm

PERFORMANCE
e Energy Class A+
Energy consumption
186kWh/yr
Max. noise level 39dB[A]
4.5kg/24hrs freezing capacity

FINISH AVAILABLE
 White

FEATURES
- Matches RiL891 larder fridge
- Super freeze function
- Mechanically controlled
- 4 Star
- Manual defrost
- Adjustable thermostat
- 100% CFC/HFC free
- Sliding door installation
- Reversible door

STORAGE
- 4 Drawers
- 1 Ice cube tray

CAPACITY
- 85 Litre total net capacity
- 93 Litre total gross capacity

INSTALLATION
- Diagram [p.262]



BUILT-UNDER LARDER FRIDGE



PRODUCT CODE

RBL4

DIMENSIONS

↔ w:595mm

PERFORMANCE

e Energy Class A+
Energy consumption
115kWh/yr
Max. noise level 39dB[A]

FINISH AVAILABLE

White

FEATURES

- Matches RBF4 freezer
- Mechanically controlled
- Auto defrost
- Adjustable thermostat
- 100% CFC/HFC free
- Fixed door installation
- Reversible door
- Interior LED light

DESIGN

- Deluxe silver trimmed door balconies
- Transparent glass shelves and plastic compartments

STORAGE

- 2 Adjustable glass shelves
- 1 Glass crisper cover shelf
- 1 Salad crispers
- 2 Plastic door storage compartments
- 1 Egg tray

CAPACITY

- 133 Litre total net capacity
- 136 Litre total gross capacity

INSTALLATION

- Diagram [p.263]

BUILT-UNDER FREEZER



PRODUCT CODE

RBF4

DIMENSIONS

↔ w:595mm

PERFORMANCE

e Energy Class A+
Energy consumption
177kWh/yr
Max. noise level 41dB[A]
9kg/24hrs freezing capacity

FINISH AVAILABLE

White

FEATURES

- Matches RBL4 larder fridge
- Mechanically controlled
- 4 Star
- Manual defrost
- Adjustable thermostat
- 100% CFC/HFC free
- Reversible door
- Fixed door installation

DESIGN

- Transparent plastic drawers

STORAGE

- 3 Drawers
- 1 Ice cube tray

CAPACITY

- 93 Litre total net capacity
- 107 Litre total gross capacity

INSTALLATION

- Diagram [p.263]

BUILT-UNDER LARDER FRIDGE WITH ICE BOX



PRODUCT CODE

RBR6

DIMENSIONS

↔ w:595mm

PERFORMANCE

e Energy Class A+
Energy consumption
171kWh/yr
Max. noise level 39dB[A]
2kg/24hrs freezing capacity

FINISH AVAILABLE

White

FEATURES

- Matches RBF4 freezer
- Mechanically controlled
- Adjustable thermostat
- 100% CFC/HFC free
- Fixed door installation
- Reversible door
- Ice box open/closed indicator

Fridge

- Auto defrost
- Interior LED light

Ice Box

- 4 Star
- Manual defrost

DESIGN

- Deluxe silver trimmed door balconies
- Transparent glass shelves and plastic compartments

STORAGE

- 1 Glass shelf
- 1 Glass crisper cover shelf
- 1 Salad crisper
- 2 Plastic door storage compartments
- 1 Egg tray
- 1 Ice cube tray

CAPACITY

- 115 Litre total net capacity
- 120 Litre total gross capacity
- 98 Litre fridge net capacity
- 17 Litre ice box net capacity

INSTALLATION

- Diagram [p.263]



Look out for products marked with Sense Premium,
Sense or Classic flags to easily identify the range.

sp s c

Wine Cabinets

Caple's wine cabinets create the optimum storage conditions for your wine; the correct temperature, humidity and air circulation. They even use low vibration technology to minimise disturbance.

And of course, they look great.



CARE FOR YOUR COLLECTION

THE RIGHT TEMPERATURE

TO STORE

All wine should be stored at 12-14°C whether red or white. Our cabinets simulate cellar conditions - dark, still, humid and a constant temperature.

TO SERVE

For rosés and whites it's 8-14°C, for sparkling wines it's 6-10°C. Full reds need 16-18°C, whereas lighter ones are best at 13-16°C. For some wine cabinets this temperature variation is a problem. However, Caple cabinets can offer multiple zones that keep all your wines at the perfect temperature for storing or better still, serving.

COMPRESSOR COOLING

When choosing a wine cabinet it's important to consider the type of cooling system it uses. Many conventional cabinets use thermo electric technology, which is only capable of cooling to 15°C below the room's ambient temperature. So on a warm day of 25°C the contents will only cool to a minimum of 10°C, leaving your wine exposed to potentially damaging temperatures.

Caple's wine cabinets use a compressor cooling system, which maintains precisely the right temperature, regardless of the ambient room temperature.

FINER WINE

Vibration and humidity during storage will influence how your wine will taste when it's finally poured. That's why Caple's wine cabinets come with anti-vibration gaskets and low vibration compressors to prevent disturbance to the wine's sediment balance. Our cabinets also create an ideal atmosphere of above 65% humidity, to preserve cork quality and prevent mould and odours. You can be confident your wine is in good hands.



THE IMPORTANCE OF LIGHTING AND STACKING

Ultraviolet light causes lightstrike, which makes wine age prematurely. So it's important to avoid exposing bottles to sunlight or fluorescent light. Our white LEDs not only look great, they are also UV-free with no heat output either.

Bottles should usually be stored on their side so the wine stays in contact with the cork. This keeps the cork moist and ensures a good air seal for the bottle, which prevents oxidation and immediate ageing. Wine benefits best from side storage if the level of the wine reaches at least the upper shoulder of the bottle when upright. Caple's wine cabinets provide sufficient shelves to allow for bottles to be stored either on a single level for easy reach, or stacked for longer storage.





WINE CABINET FEATURES

CHAMPAGNE SHELVES

The easy-slide beech shelves are non-scratch so they won't damage bottle labels. If champagne is your drink of choice, the slatted design allows you to store larger bottles so you're prepared for any special occasion.



PLINTH GRILLE

A full plinth or recessed plinth grille option is available for our undercounter wine cabinets. They neatly cover the ventilation hole in the plinth and blend in with your kitchen décor.

[Suitable for undercounter models except Wi154 and Wi155.]



UNIVERSAL PLINTH GRILLE

[code GRILL/SENSE600]

- Stainless steel top fixing plinth grille
- W 525mm



UNIVERSAL PLINTH GRILLE

[code GRILL/SENSE300]

- Stainless steel top fixing plinth grille
- W 250mm



FULL HEIGHT STAINLESS STEEL PLINTH GRILLES

w: 300mm

GRILL/CLASS301
for Wi3124 and Wi3122WH

w: 600mm

GRILL/CLASS601
for Wi6233, Wi6141, Wi6134
and Wi6134WH

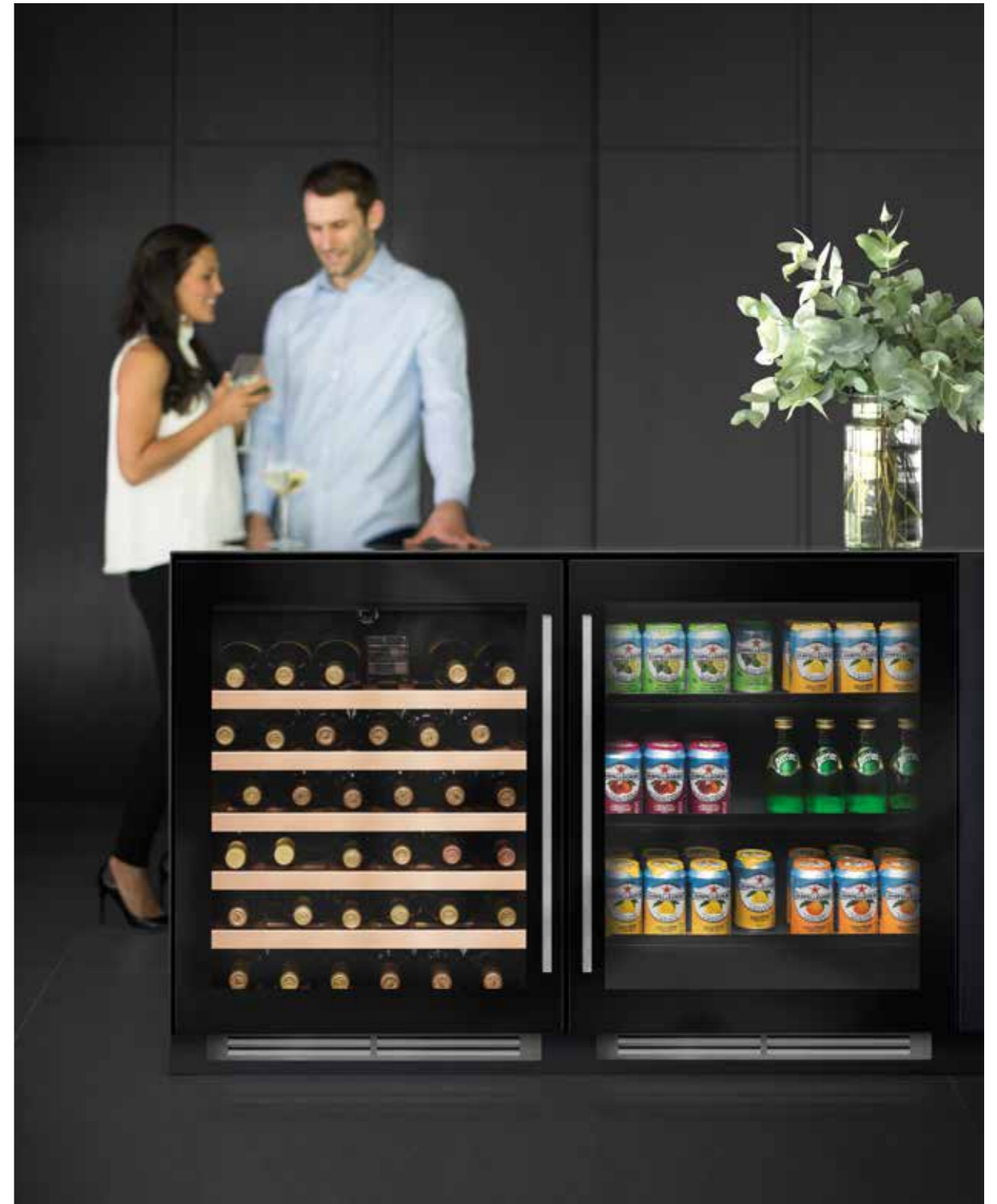

DUAL ZONE

Dual zone wine cabinets allow you to store your collection at the perfect temperature for storing and drinking.

TOUCH CONTROL WHITE LED DISPLAY

GLASS SHELVES

The three pack of glass shelves allows you to convert some of your wine cabinet into storage for canned drinks.

COOLING

194

195

WINE CABINETS

FLEXIBLE FITTING

A unique design feature incorporated into our undercounter wine cabinets allows the height of the plinth to be adjusted between 100mm and 150mm. So, you don't have to worry about your wine cabinet fitting under your work surface as they are compatible with varying plinth heights.

[Not available on the Wi154 and Wi155].



STANDARD PLINTH HEIGHT



REDUCED PLINTH HEIGHT

SENSE AND CLASSIC UNDERCOUNTER DUAL ZONE WINE CABINETS



Wi6233



Wi6232

PRODUCT CODE

Black Glass	Wi6233
Stainless Steel	Wi6232

DIMENSIONS

↔ w:595mm

PERFORMANCE

e Energy Class B
Energy consumption 195kWh/yr
Ambient temperature 16°C-32°C
Temperature range 5°C-18°C [both zones]
Humidity range >65%RH
Quiet operation 43dB[A]

FINISH AVAILABLE

	Black Glass
	Stainless Steel

GENERAL FEATURES

- No-frost compressor cooling technology maintains a consistent temperature
- Dual side-by-side temperature zones, independently controlled [both zones suitable for either red or white wine]
- Touch control and LED display
- Converts into a can chiller using optional glass shelving
- UV/heat-free white LED lighting [switchable]
- Vibration free
- Adjustable height to fit 100-150mm plinth
- Stainless steel square handles
- Beech shelves
- Fan circulated cool air for even temperature distribution
- 5 Sliding shelves and 1 base shelf per zone

- Toughened UV protected glass door
- 2 Humidity control water tanks
- 100% CFC/HFC free
- Black cabinet interior and exterior
- Recessed for fitting furniture plinth
- Air ventilation through plinth grille

Wi6233 UNIQUE FEATURES

- Black glass doors with gloss black door frame
- Supplied with stainless steel universal plinth grille w:525mm

Wi6232 UNIQUE FEATURES

- One piece stainless steel doors
- Supplied with both stainless steel universal plinth grille w:525mm and full width grille

CAPACITY

- 4.20 Cu ft/119 Litre total net capacity
- 4.73 Cu ft/134 Litre total gross capacity
- Stores max. 38 Bordeaux style wine bottles 750ml [19 bottles per zone]
- Bottle stacking diagrams available at caple.co.uk

OPTIONAL EXTRAS

- 3 Frosted glass shelves with black plastic trim [GSHELFPACK/300]
- Full height stainless steel grille with fixing brackets [GRILL/CLASS601] Wi6233 only
- Alternative black-spot handle [HANDLE3]
- Alternative curved handle [HANDLE4]

Visit caple.co.uk for full range

INSTALLATION

- Diagram [p.263]

SENSE AND CLASSIC UNDERCOUNTER DUAL ZONE WINE CABINETS



Wi6134

PRODUCT CODE

Black Glass	Wi6134
Stainless Steel	Wi6133

DIMENSIONS

w:595mm

PERFORMANCE

e Energy Class B
Energy consumption 198kWh/yr
Ambient temperature 16°C-32°C
Temperature range upper zone 5°C-10°C, lower zone 10°C-18°C
Humidity range >65%RH
Quiet operation 43dB[A]

FINISH AVAILABLE

Black Glass
Stainless Steel

GENERAL FEATURES

- No-frost compressor cooling technology maintains a consistent temperature
- Dual stacked temperature zones, independently controlled [upper zone, lower zone]
- Touch control and LED display
- UV/heat-free white LED lighting [switchable]
- Vibration free
- Adjustable height to fit 100-150mm plinth
- Stainless steel square handle
- Beech shelves
- Fan circulated cool air for even temperature distribution
- Heater raises internal temperature when external temperature drops
- Reversible door
- Upper zone has 2 sliding shelves
- Lower zone has 3 sliding shelves and 1 base shelf

- Toughened UV protected glass door
- 2 Humidity control water tanks
- 100% CFC/HFC free
- Black cabinet interior and exterior
- Recessed for fitting furniture plinth
- Air ventilation through plinth grille

Wi6134 UNIQUE FEATURES

- Black glass doors with gloss black door frame
- Supplied with stainless steel universal plinth grille w:525mm

Wi6133 UNIQUE FEATURES

- One piece stainless steel door
- Supplied with both stainless steel universal plinth grille w:525mm and full width grille

CAPACITY

- 4.73 Cu Ft/134 Litre total net capacity
- 5.79 Cu ft/164 Litre total gross capacity
- Stores max. 46 Bordeaux style wine bottles 750ml [16 white and 30 red bottles]
- Bottle stacking diagrams available at caple.co.uk

OPTIONAL EXTRAS

- Full height stainless steel grille with fixing brackets [GRILL/CLASS601]
- Alternative black-spot bar handle [HANDLE3]
- Alternative curved handle [HANDLE4]
- Visit caple.co.uk for full range

INSTALLATION

- Diagram [p.263]

SENSE UNDERCOUNTER DUAL ZONE WINE CABINET



PRODUCT CODE

Wi6132WH

DIMENSIONS

w:595mm

FINISH AVAILABLE

White Glass

PERFORMANCE

e Energy Class B
Energy consumption 198kWh/yr
Ambient temperature 16°C-32°C
Temperature range upper zone 5°C-10°C, lower zone 10°C-18°C
Humidity range >65%RH
Quiet operation 43dB[A]

FEATURES

- No-frost compressor cooling technology maintains a consistent temperature
- Dual stacked temperature zones, independently controlled [upper zone, lower zone]
- Electronic temperature control and LED display
- UV/heat-free white LED lighting [switchable]
- Vibration free
- Adjustable height to fit 100-150mm plinth
- White glass door with white door frame
- Supplied with both stainless steel square handle and black-spot bar handle
- Stainless steel fronted beech shelves
- Fan circulated cool air for even temperature distribution
- Heater raises internal temperature when external temperature drops
- Reversible door
- Upper zone has 2 sliding shelves
- Lower zone has 3 sliding shelves and 1 base shelf



PRODUCT CODE

- Toughened UV protected glass door
- 2 Humidity control water tanks
- 100% CFC/HFC free
- Black cabinet interior and exterior
- Recessed for fitting furniture plinth
- Air ventilation through plinth grille
- Supplied with stainless steel universal plinth grille w:525mm

OPTIONAL EXTRAS

- Full height stainless steel grille with fixing brackets [GRILL/CLASS601]
- Visit caple.co.uk for full range

INSTALLATION

- Diagram [p.263]

CAPACITY

- 4.73 Cu Ft/134 Litre total net capacity
- 5.79 Cu ft/164 Litre total gross capacity
- Stores max. 46 Bordeaux style wine bottles 750ml [16 white and 30 red bottles]
- Bottle stacking diagrams available at caple.co.uk

Wi6133



SENSE AND CLASSIC UNDERCOUNTER SINGLE ZONE WINE CABINETS



Wi6141

PRODUCT CODE

Black Glass	Wi6141
Stainless Steel	Wi6140

DIMENSIONS

↔ w:595mm

PERFORMANCE

e Energy Class A
Energy consumption 145kWh/yr
Ambient temperature 16°C-32°C
Temperature range 5°C-18°C
Humidity range >65%RH
Quiet operation 43dB[A]

FINISH AVAILABLE

	Black Glass
	Stainless Steel

GENERAL FEATURES

- No-frost compressor cooling technology maintains a consistent temperature
- Single temperature zone stores red, white or sparkling wine
- Touch controls and LED display
- Converts into a can chiller using optional glass shelving
- UV/heat-free white LED lighting [switchable]
- Vibration free
- Adjustable height to fit 100-150mm plinth
- Stainless steel square handle
- Beech shelves
- Fan circulated cool air for even temperature distribution
- Reversible door
- 5 Sliding shelves and 1 base shelf
- Toughened UV protected glass door
- 1 Humidity control water tanks
- 100% CFC/HFC free



Wi6140

GENERAL FEATURES

- Black cabinet interior and exterior
- Recessed for fitting furniture plinth
- Air ventilation through plinth grille

Wi6141 UNIQUE FEATURES

- Black glass doors with gloss black door frame
- Supplied with stainless steel universal plinth grille w:525mm

Wi6140 UNIQUE FEATURES

- One piece stainless steel door
- Supplied with both stainless steel universal plinth grille w:525mm and full width grille

CAPACITY

- 5.15 Cu Ft/146 Litre total net capacity
- 5.79 Cu ft/164 Litre total gross capacity
- Stores max. 52 Bordeaux style wine bottles 750ml [8 bottles per sliding shelf, 6 bottles on base shelf, 14 on top shelf]
- Bottle stacking diagrams available at caple.co.uk

OPTIONAL EXTRAS

- 3 Frosted glass shelves with black plastic trim [GSHELFPACK/600]
- Full height stainless steel grille with fixing brackets [GRILL/CLASS601]
- Alternative black-spot bar handle [HANDLE3]
- Alternative curved handle [HANDLE4]

Visit caple.co.uk for full range

INSTALLATION

- Diagram [p.263]

SENSE AND CLASSIC UNDERCOUNTER SINGLE ZONE WINE CABINETS



Wi3124

PRODUCT CODE

Black Glass	Wi3124
Stainless Steel	Wi3123

DIMENSIONS

↔ w:295mm

PERFORMANCE

e Energy Class A
Energy consumption 140kWh/yr
Ambient temperature 16°C-32°C
Temperature range 5°C-18°C
Humidity range >65%RH
Quiet operation 43dB[A]

FINISH AVAILABLE

	Black Glass
	Stainless Steel

GENERAL FEATURES

- No-frost compressor cooling technology maintains a consistent temperature
- Single temperature zone stores red, white or sparkling wine
- Touch control and LED display
- Converts into a can chiller using optional glass shelving
- UV/heat-free white LED lighting [switchable]
- Vibration free
- Adjustable height to fit 100-150mm plinth
- One piece stainless steel door
- Stainless steel square handle
- Beech shelves
- Fan circulated cool air for even temperature distribution
- Reversible door
- 5 Sliding shelves and 1 base shelf

- Toughened UV protected glass door
- 1 Humidity control water tank
- 100% CFC/HFC free
- Black cabinet interior and exterior
- Recessed for fitting furniture plinth
- Air ventilation through plinth grille

Wi3124 UNIQUE FEATURES

- Black glass doors with gloss black door frame
- Supplied with stainless steel universal plinth grille w:2305mm

Wi3123 UNIQUE FEATURES

- One piece stainless steel door
- Supplied with both stainless steel universal plinth grille w:230mm and full width grille

CAPACITY

- 1.98 Cu Ft/56 Litre total net capacity
- 2.33 Cu ft/66 Litre total gross capacity
- Stores max.19 Bordeaux style wine bottles 750ml
- Bottle stacking diagrams available at caple.co.uk

OPTIONAL EXTRAS

- 3 Frosted glass shelves with black plastic trim [GSHELFPACK/300]
- Full height stainless steel grille with fixing brackets [GRILL/CLASS301]
- Alternative black-spot bar handle [HANDLE3]
- Alternative curved handle [HANDLE4]

Visit caple.co.uk for full range

INSTALLATION

- Diagram [p.264]



Wi3123

SENSE UNDERCOUNTER SINGLE ZONE WINE CABINET



PRODUCT CODE
Wi3122WH

DIMENSIONS
w:295mm

PERFORMANCE
e Energy Class B
 Energy consumption 190kWh/yr
 Ambient temperature 16°C-32°C
 Temperature range 5°C-18°C
 Humidity range >65%RH
 Quiet operation 43dB[A]

FINISH AVAILABLE
 White Glass

FEATURES

- No-frost compressor cooling technology maintains a consistent temperature
- Single temperature zone stores red, white or sparkling wine
- Electronic temperature control and LED display
- Converts into a can chiller using optional glass shelving
- UV/heat-free white LED lighting [switchable]
- Vibration free
- Adjustable height to fit 100-150mm plinth
- White glass door with gloss white door frame
- Supplied with both stainless steel square handle and black-spot bar handle
- Stainless steel fronted beech shelves



- Fan circulated cool air for even temperature distribution
- Reversible door
- 5 Sliding shelves and 1 base shelf
- Toughened UV protected glass door
- 1 Humidity control water tank
- 100% CFC/HFC free
- Black cabinet interior and exterior
- Recessed for fitting furniture plinth
- Air ventilation through plinth grille
- Supplied with stainless steel universal plinth grille w:230mm

CAPACITY

- 2.12 Cu Ft/60 Litre total net capacity
 - 2.33 Cu ft/66 Litre total gross capacity
 - Stores max.19 Bordeaux style wine bottles 750ml
- Bottle stacking diagrams available at cagle.co.uk

OPTIONAL EXTRAS

- 3 Frosted glass shelves with black plastic trim [GSHELFPACK/300]
 - Full height stainless steel grille with fixing brackets [GRILL/CLASS301]
- Visit cagle.co.uk for full range

INSTALLATION

- Diagram [p.264]

SENSE AND CLASSIC UNDERCOUNTER SINGLE ZONE WINE CABINETS



Wi154



Wi155

PRODUCT CODE
 Black Glass Wi154
 Stainless Steel Wi155

DIMENSIONS
 w:145mm

PERFORMANCE
e Energy Class B
 Energy consumption 185kWh/yr
 Ambient temperature 16°C-32°C
 Temperature range 5°C-18°C
 Humidity range >65%RH
 Quiet operation 44dB[A]

FINISH AVAILABLE
 Black Glass
 Stainless Steel

FEATURES

- No-frost compressor cooling technology maintains a consistent temperature
- Single temperature zone stores red, white or sparkling wine
- Electronic temperature control and LED display
- UV/heat-free white LED lighting [switchable]
- Vibration free
- Black glass door with gloss black door frame
- Fan circulated cool air for even temperature distribution
- Reversible door
- 6 Black wire shelves and 1 base shelf
- 100% CFC/HFC free
- Toughened UV protected glass door
- Black cabinet interior and exterior
- Electronic temperature control and LED display
- Air ventilation through plinth grille

WI154 UNIQUE FEATURES

- Black glass door with gloss black door frame
- Stainless steel black-spot bar handle

WI155 UNIQUE FEATURES

- One piece stainless steel door
- Curved stainless steel handle

CAPACITY

- 0.67 Cu ft/19 Litre total net capacity
 - 0.78 Cu ft/22 Litre total gross capacity
 - Stores max. 7 Bordeaux style wine bottles 750ml
 - Not suitable for some champagne bottles
- Bottle stacking diagrams available at cagle.co.uk

OPTIONAL EXTRAS

- Sense square stainless steel handle [HANDLE8]
 - Classic square stainless steel handle [HANDLE7]
- Visit cagle.co.uk for full range

INSTALLATION

- Diagram [p.264]

SENSE AND CLASSIC IN-COLUMN TRIPLE ZONE WINE CABINETS



WC1795

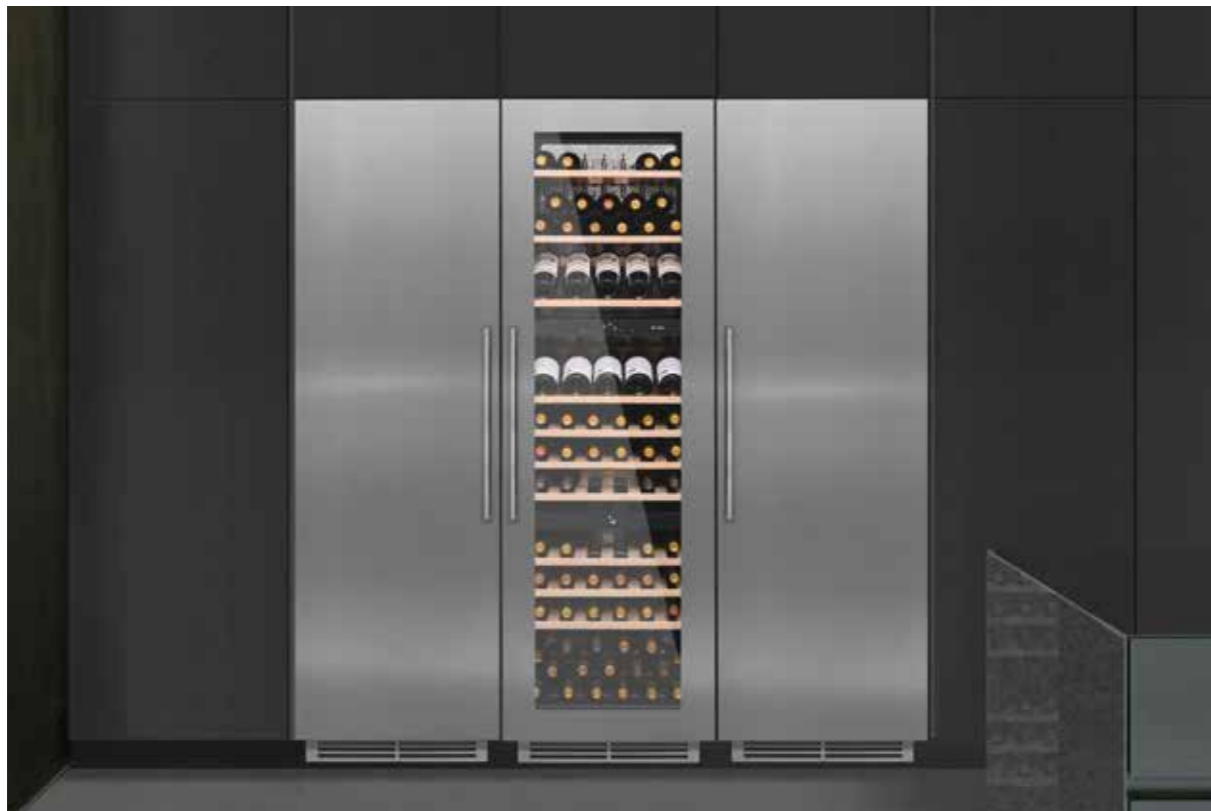

WC179

PRODUCT CODE

Black Glass	WC1795
Stainless Steel	WC179

DIMENSIONS

h:1788mm

FINISH AVAILABLE

- Black Glass
- Stainless Steel

PERFORMANCE

- Energy Class B
- Energy consumption 216kWh/yr
- Ambient temperature 16°C-32°C
- Temperature range upper zone 5°C-18°C, middle zone 5°C-10°C, lower zone 10°C-18°C
- Humidity range >65%RH
- Quiet operation 45dB[A]

FEATURES

- No-frost compressor cooling technology maintains a consistent temperature
- Triple stacked temperature zones for red, white and sparkling wine independently controlled
- Electronic temperature control and LED display
- Fan circulated cool air for even temperature distribution
- UV/heat-free white LED lighting [switchable]
- Vibration free
- Black glass door with black gloss frame
- Black cabinet interior and stainless steel back panel
- Square stainless steel handle
- Telescopic beech shelves
- High temperature alarm
- 2 Heaters raise internal temperature when external temperature drops
- Reversible door

- Upper zone has 2 sliding shelves and 1 display shelf
- Middle zone has 3 sliding shelves and 1 display shelf
- Lower zone has 3 sliding shelves and 1 base shelf
- Double stacked shelves
- 100% CFC/HFC free
- Toughened UV protected glass door
- 3 Humidity control water tanks
- Supplied with stainless steel universal plinth grille w:525mm
- Air ventilation through plinth grille

WC1795 UNIQUE FEATURES

- Black glass doors with gloss black door frame
- Supplied with both square and curved stainless steel handle

WC179 UNIQUE FEATURES

- One piece stainless steel doors
- Square stainless steel handle

CAPACITY

- 8.69 Cu ft/246 Litre total net capacity
- 10.14 Cu ft/287 Litre total gross capacity
- Stores max. 89 Bordeaux style wine bottles 750ml [29 bottles on upper zone, 25 bottles on middle zone and 35 bottles on lower zone]
- Bottle stacking diagrams available at caple.co.uk

OPTIONAL EXTRAS

- Alternative black-spot handle [HANDLE3]
 - Curved stainless steel handle [HANDLE4]
 - Sense square stainless steel handle [HANDLE8]
 - Classic square stainless steel handle [HANDLE7]
- Visit caple.co.uk for full range

INSTALLATION

- Diagram [p.265]

SENSE AND CLASSIC IN-COLUMN DUAL ZONE WINE CABINETS



WC6520



WC6510

PRODUCT CODE

Black Glass WC6520
Stainless Steel WC6510

DIMENSIONS

h:886mm

PERFORMANCE

e Energy Class B
Energy consumption 198kWh/yr
Ambient temperature 16°C-32°C
Temperature range upper zone 5°C-10°C, lower zone 10°C-18°C
Humidity range >65%RH
Quiet operation 45dB[A]

FINISH AVAILABLE

Black Glass
Stainless Steel

FEATURES

- No-frost compressor cooling technology maintains a consistent temperature
- Dual stacked temperature zones, independently controlled [upper zone wine, lower zone]
- Touch controls and LED display
- UV/heat-free white LED lighting [switchable]
- Vibration free
- Black glass door with gloss black door frame
- Stainless steel square handle
- Beech shelves
- Fan circulated cool air for even temperature distribution
- Heater raises internal temperature when external temperature drops
- Reversible door
- Upper zone has 3 sliding shelves
- Lower zone has 3 sliding shelves and 1 sliding base shelf

FEATURES

- 100% CFC/HFC free
- Toughened UV protected glass door
- 2 Humidity control water tanks
- Black cabinet interior and exterior
- Audible door alarm when left open

WC6520 UNIQUE FEATURES

- Black glass doors with gloss black door frame

WC6510 UNIQUE FEATURES

- One piece stainless steel doors

CAPACITY

- 4.13 Cu ft/117.1 Litre total net capacity
 - 4.94 Cu ft/140.1 Litre total gross capacity
 - Stores max. 41 Bordeaux style wine bottles 750ml [18 white bottles on upper zone, and 23 red bottles on lower zone]
- Bottle stacking diagrams available at caple.co.uk

INSTALLATION

- Diagram [p.265]



CLASSIC IN-COLUMN SINGLE ZONE WINE CABINET

PRODUCT CODE

WC6500

DIMENSIONS

h:886mm

FINISH AVAILABLE

Stainless Steel

PERFORMANCE

e Energy Class A
Energy consumption 146kWh/yr
Ambient temperature 16°C-32°C
Temperature range 5°C-18°C
Humidity range >65%RH
Quiet operation 45dB[A]

FEATURES

- No-frost compressor cooling technology maintains a consistent temperature
- Single temperature zone stores red, white or sparkling wine
- Touch control and LED display
- UV/heat-free white LED lighting [switchable]
- Vibration free
- One piece stainless steel door
- Black cabinet interior and exterior
- Stainless steel square handle
- Beech shelves
- Fan circulated cool air for even temperature distribution
- Reversible door
- 7 Sliding shelves and 1 base shelf
- 100% CFC/HFC free
- Toughened UV protected glass door
- 1 Humidity control water tank
- Audible door alarm when left open

CAPACITY

- 4.38 Cu ft/124 Litre total net capacity
 - 5.41 Cu ft/153 Litre total gross capacity
 - Stores max. 47 Bordeaux style wine bottles 750ml
- Bottle stacking diagrams available at caple.co.uk

INSTALLATION

- Diagram [p.265]

SENSE AND CLASSIC IN-COLUMN SINGLE ZONE WINE CABINETS



WC6410



WC6400

PRODUCT CODE

Black Glass	WC6410
Stainless Steel	WC6400

DIMENSIONS

h:455mm

FINISH AVAILABLE

- Black Glass
- Stainless Steel

PERFORMANCE

e Energy Class A
 Energy consumption 139kWh/yr
 Ambient temperature 16°C-32°C
 Temperature range 5°C-18°C
 Humidity range >65%RH
 Quiet operation 43dB[A]

FEATURES

- No-frost compressor cooling technology maintains a consistent temperature
- Single temperature zone for red or white wine
- Touch control and LED display
- UV/heat-free white LED lighting [switchable]
- Vibration free
- Stainless steel square handle
- Beech shelves
- Fan circulated cool air for even temperature distribution
- Reversible door
- 3 Sliding shelves and 1 base shelf
- 100% CFC/HFC free
- Toughened UV protected glass door
- 1 Humidity control water tank
- Audible door alarm when left open

WC6410 UNIQUE FEATURES

- Black glass doors with gloss black door frame

WC6400 UNIQUE FEATURES

- One piece stainless steel door

CAPACITY

- 1.91 Cu ft/54 Litre total net capacity
 - 2.08 Cu ft/59 Litre total gross capacity
 - Stores max. 21 Bordeaux style wine bottles 750ml
- Bottle stacking diagrams available at caple.co.uk

INSTALLATION

- Diagram [p.265]



SENSE FREESTANDING TRIPLE ZONE WINE CABINET

PRODUCT CODE

WF1549

DIMENSIONS

h:1762mm

FINISH AVAILABLE

- Black Glass

PERFORMANCE

e Energy Class C
 Energy consumption 290kWh/yr
 Ambient temperature 16°C-32°C
 Temperature range upper zone 5°C-18°C, middle zone 5°C-12°C, lower zone 12°C-18°C
 Humidity range >65%RH
 Quiet operation 45dB[A]

FEATURES

- No-frost compressor cooling technology maintains a consistent temperature
- Triple stacked temperature zones for red, white or sparkling wine, independently controlled
- Electronic temperature control and LED display
- UV/heat-free white LED lighting [switchable]
- 100% CFC/HFC free
- Vibration free
- Fan circulated cool air for even temperature distribution
- 2 Heaters raise internal temperature when external temperature drops
- Reversible door
- Upper zone has 1 sliding shelf and 1 display shelf
- Middle zone has 2 sliding shelves and 1 display shelf
- Lower zone has 3 sliding shelves and 1 base shelf

- Toughened UV protected glass door
- 3 Humidity control water tanks
- Door lock
- Air ventilation through plinth grille

DESIGN

- Black glass door with gloss black door frame
- Stainless steel, black-spot feature bar handle
- Telescopic shelves
- Black cabinet interior and exterior

CAPACITY

- 14.23 Cu ft/404 Litre total net capacity
- 15.86 Cu ft/449 Litre total gross capacity
- Stores max. 132 Bordeaux style wine bottles 750ml [43 bottles on upper zone, 45 bottles on middle zone and 44 bottles on lower zone]

INSTALLATION

- Diagram [p.266]



CLASSIC FREESTANDING TRIPLE ZONE WINE CABINET

PRODUCT CODE

WF1548

DIMENSIONS

h:1762mm

PERFORMANCE

e Energy Class C
 Energy consumption 290kWh/yr
 Ambient temperature 16°C-32°C
 Temperature range upper zone 5°C-18°C, middle zone 5°C-12°C, lower zone 12°C-18°C
 Humidity range >65%RH
 Quiet operation 45dB[A]

FINISH AVAILABLE

Stainless Steel

FEATURES

- No-frost compressor cooling technology maintains a consistent temperature
- Triple stacked temperature zones for red, white or sparkling wine, independently controlled
- Electronic temperature control and LED display
- UV/heat-free white LED lighting [switchable]
- 100% CFC/HFC free
- Vibration free
- Fan circulated cool air for even temperature distribution
- 2 Heaters raise internal temperature when external temperature drops
- Reversible door
- Upper zone has 1 sliding shelf and 1 display shelf
- Middle zone has 2 sliding shelves and 1 display shelf
- Lower zone has 3 sliding shelves and 1 base shelf

- Toughened UV protected glass door
- 3 Humidity control water tanks
- Door lock
- Air ventilation through stainless steel plinth grille

DESIGN

- One piece stainless steel door
- Stainless steel fronted telescopic beech shelves
- Curved stainless steel handle
- Black cabinet interior and exterior

CAPACITY

- 14.23 Cu ft/404 Litre total net capacity
- 15.86 Cu ft/449 Litre total gross capacity
- Stores max. 132 Bordeaux style wine bottles 750ml [43 bottles on upper zone, 45 bottles on middle zone and 44 bottles on lower zone]

INSTALLATION

- Diagram [p.266]



CLASSIC FREESTANDING SINGLE ZONE WINE CABINET

PRODUCT CODE

WF333

DIMENSIONS

h:840mm

PERFORMANCE

e Energy Class A
 Energy consumption 144kWh/yr
 Temperature range 5°C-18°C
 Ambient temperature 16°C-32°C
 Humidity range >65%RH
 Quiet operation 44dB[A]

FINISH AVAILABLE

Stainless Steel

FEATURES

- No-frost compressor cooling technology maintains a consistent temperature
- Single temperature zone for red or white wine
- Electronic temperature control and LED display
- Interior light
- 100% CFC/HFC free
- 3 Full shelves and 1 half shelf
- Toughened UV protected glass door
- 1 Humidity control water tank
- Reversible door
- Top and side heat dispersion

DESIGN

- One piece stainless steel door
- Curved stainless steel handle
- Stainless steel fronted telescopic beech shelves
- Black cabinet interior and exterior

CAPACITY

- 4.39 Cu ft/124 Litre total net capacity
- 4.87 Cu ft/138 Litre total gross capacity
- Stores max. 39 Bordeaux style wine bottles 750ml [6 bottles on top shelf, 12 bottles double stacked on middle two shelves and 9 bottles double stacked on the bottom shelf]

INSTALLATION

- Diagram [p.266]

WASHING

Dishwashers	216
Washing Machines	225
Washer Dryer	228
Tumble Dryers	230





Taking the chore out of washing

Who says that functional objects can't look fantastic? That's why we've designed our dishwasher and laundry appliances with an eagle eye on performance and style

Caple is renowned for ultra stylish looks, hi-tech and all-round ease of use. With fast, efficient clothes washing and drying and sparkling clean dishes, our appliances will always get the job done beautifully with minimal effort.

WASH HOWEVER YOU WISH

Our range of washing appliances gives you all the options you need to fit in with your kitchen and your budget. What's on your wish list? An appliance that makes the most of minimal space? One that can cope with a large family? Or super stylish looks? We tick all your boxes.



Our dishwashers are exceptionally versatile, using clever technology to deal with any type of load. Our washing machines and washer dryers make light work of all your laundry needs with features like allergy care, stain reduction and extra large doors. What's more, Caple tumble dryers can be kept neatly behind furniture doors for a flawless finish.



Dishwashers

Our machines don't just leave your dishes sparkling, they also come with at least an A+' rating for energy and A for wash and drying performance.



PERFORMANCE WITH SHINE

Whether it's a quick wash or something more heavy-duty, every Caple dishwasher is designed to perform well. All models are fully integrated to tuck away behind your kitchen doors and are at least A+ energy rated, with the top of the range model now an amazing A+++.



WATER CONSUMPTION

The entire range has low water consumption figures, which is not only great for the environment but your pocket also. The Auto Wash programme on the Di491 uses an astonishingly low 8 litres of water.



POWER WASH AND AUTO WASH

Exclusive to the Di651. Power Wash, when used with either intensive, normal, economy, glass and one hour express programmes, helps break through heavily soiled loads by increasing washing temperature and duration.

Auto wash on Di651 and Di491 have sensors checking the level of cleanliness of the load, saving you time, energy and water.



ADJUSTABLE UPPER BASKET

You can change the height of the upper basket [even with full loads] with the simple release of two conveniently placed levers. This is available on Di651, Di627 and Di491 models.



ALTERNATIVE WASH

This is available on Di651 and Di491 allowing you to select either the upper or lower baskets for the load. You'll save water and energy with smaller loads.



INTERNAL LED LIGHT

Activated when the door is opened, it illuminates the inside.



DELAY TIMER

Allows you to delay the start time for between 1-24 hours.

REDUCE YOUR WATER AND ENERGY USAGE

The Half Load function on our models is ideally suited to small loads, unlike traditional Half Load programmes [which usually only use one basket] reducing energy and water use.

AQUASTOP

Automatically cuts off the water at the first sign of a leak, helping to avoid costly water damage.

Features

FLEXIBLE CUTLERY TRAY

Models Di651, Di627 and Di491 feature clever cutlery trays that sit at the top of the dishwasher freeing up more space in the lower basket. On the 600mm models you can choose from five set-up options, [shown below] depending on what is in the basket below.





FULLY INTEGRATED DISHWASHER



PRODUCT CODE

Di651

DIMENSIONS

↔ w:600mm

PERFORMANCE

e Energy Class A+++
 Wash Class A
 Drying performance A
 Max. noise level 40dB[A]
 Annual energy consumption 241kWh/yr
 Annual water consumption 2800 Litres
 Water consumption [economy] from 10 Litres
 Energy consumption per cycle [economy] 0.84kWh

FINISH AVAILABLE

■ Stainless steel control panel with LCD display

PROGRAMMES

7 Programmes
 *Normal/55°C
 *Intensive/60°C
 *Economy/45°C
 90min express/65°C
 Auto/ 45-55°C
 Glass/40°C
 Rapid/45°C

FUNCTIONS

- Express wash
- Extra drying / Turbo drying
- Power wash
- Alternative wash
- Delayed timer 1-24hr

FEATURES

- 15 Place settings
- Max. plate diameter 30cm
- Stainless steel inner door and interior
- Stainless steel direct touch control panel
- Programme status light
- Internal light
- Top cutlery tray
- Titanium grey baskets
- Electronic salt and rinse aid warning light
- Cold water connection
- 3 spray levels
- Hidden heating element
- Easy adjustable upper basket
- Sliding door dispenser
- Easy clean filter system
- 6 Level water softening system
- Water overflow protection system
- Aquastop

INSTALLATION

- Diagram [p.266]
- Voltage 220 - 240V
- Rated load 1.93kW
- Fuse rating 10A

Features

Due to the whisper quiet nature of the Di651, this appliance has a convenient programme status light [shown below] projecting onto the floor during the cycle. This light turns off when complete.

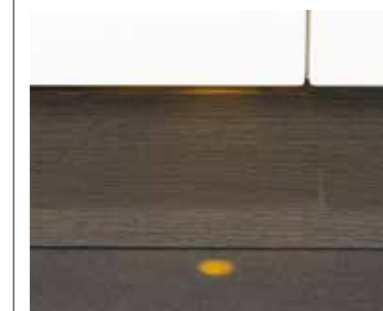

Easy adjustable upper basket [shown below] on Di651, Di627 and Di491.





FULLY INTEGRATED DISHWASHER



PRODUCT CODE
Di627

FUNCTIONS
- Delayed timer 1-24hr
- Half load

DIMENSIONS
↔ w:600mm

PERFORMANCE

e Energy Class A++
Wash Class A
Drying performance A
Max. noise level 49dB
Annual energy consumption 266kWh/yr
Annual water consumption 3080 Litres
Water consumption [economy] 11 Litres

FINISH AVAILABLE

Silver control panel with electronic display

PROGRAMMES

6 Programmes
Normal/55°C
Intensive/65°C
Economy/45°C
90min express/60°C
Glass/40°C
Rapid/40°C

INSTALLATION

- Diagram [p.266]
- Voltage 230V
- Rated load 1.93kW
- Fuse rating 13A

FULLY INTEGRATED DISHWASHER



PRODUCT CODE
Di631

FUNCTIONS
- Delay timer 3, 6 or 9hrs

DIMENSIONS
↔ w:600mm

PERFORMANCE

e Energy Class A+++
Wash Class A
Drying performance A
Max. noise level 49dB
Annual energy consumption 258kWh/yr
Annual water consumption 3080 Litres
Water consumption [economy] 11 Litres
Energy consumption per cycle [economy] 0.91kWh

FINISH AVAILABLE

Black gloss door top control panel

PROGRAMMES

5 Programmes
Normal/55°C
Intensive/65°C
Economy/50°C
1 hour/60°C
Rapid/40°C

FEATURES

- 12 Place settings
- Max. plate diameter 30cm
- Stainless steel inner door and interior
- Titanium grey baskets
- Salt and rinse aid warning light
- Cold water connection
- Hidden heating element
- Adjustable upper basket
- Easy clean filter system
- 6 Level water softening system
- Water overflow protection system

INSTALLATION

- Diagram [p.266]
- Voltage 230V
- Rated load 1.93kW
- Fuse rating 13A

FULLY INTEGRATED DISHWASHER



PRODUCT CODE
Di491

FUNCTIONS
- Delayed timer 1-24hr
- Alternative wash
- Extra drying
- Extra wash
- Power wash
- Energy saving mode

DIMENSIONS
↔ w:450mm

PERFORMANCE

e Energy Class A+++
Wash Class A
Drying performance A
Max. noise level 42dB
Annual energy consumption 188kWh/yr
Annual water consumption 2240 Litres
Water consumption [economy] 8 Litres
Energy consumption per cycle [economy] 0.66kWh

FINISH AVAILABLE

Stainless steel control panel with LED display

PROGRAMMES

8 Programmes
Auto/45-55°C
Normal/55°C
Intensive/60°C
Economy/45°C
90min/65°C
Glass/40°C
Rapid/45°C
Pre-wash

FEATURES

- 10 Place settings
- Max. plate diameter 30cm
- Stainless steel inner door and interior
- Internal light
- Top cutlery tray
- Titanium grey baskets
- Cold water connection
- Hidden heating element
- Easy adjustable upper basket
- Easy clean filter system
- Electronic salt and rinse aid warning light
- 6 Level water softening system
- Water overflow protection system
- Aquastop

INSTALLATION

- Diagram [p.265]
- Voltage 220-240V
- Rated load 2.1kW
- Fuse rating 10A

FULLY INTEGRATED DISHWASHER



PRODUCT CODE
Di481

FUNCTIONS
- Delayed timer 3, 6 or 9hrs

DIMENSIONS
↔ w:450mm

PERFORMANCE

e Energy Class A++
Wash Class A
Drying performance A
Max. noise level 49dB
Annual energy consumption 197kWh/yr
Energy consumption per cycle 0.74kWh/cycle
Annual water consumption 2520 Litres
Water consumption [economy] 9 Litres

FINISH AVAILABLE

Black gloss door top control panel

PROGRAMMES

5 Programmes
Normal/55°C
Intensive/65°C
Economy/50°C
1 Hour express/60°C
Rapid/40°C

FEATURES

- 9 Place settings
- Max. plate diameter 30cm
- Stainless steel inner door and interior
- Titanium grey baskets
- Salt and rinse aid warning light
- Cold water connection
- Hidden heating element
- Adjustable upper basket
- Easy clean filter system
- 6 Level water softening system
- Water overflow protection system

INSTALLATION

- Diagram [p.267]
- Voltage 230V
- Rated load 1.93kW
- Fuse rating 13A



Laundry

A reliable washing machine and tumble dryer is an absolute must for any family. We've taken things further, with a range that's packed with features, good looks and performance.

WASHING MACHINES

Choose from a selection of integrated machines that tuck neatly away. Whichever you opt for, you can be sure it will do the job in style. All our machines use the most advanced technology to make laundry day just that bit easier.

DIGITAL DISPLAY

Included on all models. Shows the programme phase, spin speed and any extra functions selected.



EXTRA LARGE DOORS

Makes loading and unloading much easier.



MY CYCLE

Create and easily access your most frequently used programme.



SUPERIOR FABRIC PROTECTION

The new Caple Diamond+ Drum offers superior fabric protection, allowing clothes to gently glide across the surface preventing rips, laddering and pilling.



ELECTRONIC WASHING MACHINE



PRODUCT CODE
WMi3005

DIMENSIONS
w:600mm

PERFORMANCE

e Energy Class A+++
Wash Class A
Spin efficiency B
1400rpm max.
spin speed
11000 Litre annual
water consumption
Est. annual energy
consumption 196kWh/yr
Max. noise level wash
57dB, spin 76dB

FINISH AVAILABLE
 White

PROGRAMMES

16 Programmes
Cotton Intensive
Cotton 60°C
Cotton 40°C
Cotton 20°C
15min Quick wash
Eco
Rinse
Baby care
Sports
Synthetic

Mixed
Delicate
Wool
Drain
Spin
My Cycle

7 Options

Delay timer [up to 24hrs]
Pause
Intense
Spin speed selection
Temperature selection
Pre wash
Extra rinse

FEATURES

- Cold fill
- 15 minute fast wash
- Digital display
- 310mm extra large door
- Door safety lock
- Programme time remaining
- Variable spin speed
- Stainless steel Diamond+ drum
- Anti-overflow protection
- Foam control

CAPACITY

- 8kg washing capacity

INSTALLATION

- Diagram [p.267]
- Rated load 2.0kW
- Fuse rating 10A

ELECTRONIC WASHING MACHINE



PRODUCT CODE
WMi3000

DIMENSIONS
w:600mm

PERFORMANCE

e Energy Class A++
Wash Class A
Spin efficiency B
1200rpm max.
spin speed
9240 Litre annual
water consumption
Est. annual energy
consumption 173kWh/yr
Max. noise level wash
57dB, spin 74dB

FINISH AVAILABLE
 White

PROGRAMMES

16 Programmes
Cotton Intensive
Cotton 60°C
Cotton 40°C
Cotton 20°C
15min Quick wash
Eco
Rinse
Baby care
Sports
Synthetic

Mixed
Delicate
Wool
Drain
Spin
My Cycle

7 Options

Delay timer [up to 24hrs]
Pause
Intense
Spin selection
Temperature selection
Pre wash
Extra rinse

FEATURES

- Cold fill
- 15mins fast wash
- Digital display
- 300mm extra large door
- Door safety lock
- Programme time remaining
- Variable spin speed
- Stainless steel Diamond+ drum
- Anti-overflow protection
- Foam control

CAPACITY

- 6kg washing capacity

INSTALLATION

- Diagram [p.267]
- Rated load 2.0kW
- Fuse rating 10A

WASHER DRYER

Our integrated washer dryer offers multiple programmes that are easy to operate, meeting all your laundry needs with minimal fuss.

ELECTRONIC CONTROLS

Simple controls mean you can change between options at the click of a button.

DOOR SAFETY LOCK

Our machine operates at high temperatures during mid-cycle. The door will remain locked until the clothes cool 53°C.

STAIN REDUCTION

Uses advanced technology to maximise cleaning action, keeping your whites looking fresher for longer.



ELECTRONIC CONDENSER WASHER DRYER



PRODUCT CODE
WDi2203

DIMENSIONS
w:600mm

PERFORMANCE

e Energy Class B
Wash Class A
Spin efficiency B
1200rpm max. spin speed
98 Litre water consumption
[wash and dry cycle]
Est. energy to wash and dry
full load 4.84kWh
Max. noise level wash 58dB,
spin 72dB, dry 57dB

FINISH AVAILABLE
 White

PROGRAMMES

11 Programmes
Fast wash 15mins
Cotton
Synthetic
Wool
Delicate
Underwear
Pre-wash
Spin
Refresh
Dry
Self-clean

7 Options

Delay timer
Pause
Spin selection
Temperature selection
Intense
Extra rinse
Dry

FEATURES

- Final cool down tumble
- Cold fill
- 15 Minute fast wash
- Digital display
- Electronic controls
- 320mm extra large door
- Door safety lock
- Programme time remaining
- Variable spin speed
- Automatic variable load
- Stainless steel drum
- Anti-overflow protection
- Pause function

CAPACITY

- 6kg washing, 3kg drying capacity

INSTALLATION

- Diagram [p.267]
- Rated load 2.0kW
- Fuse rating 13A

TUMBLE DRYERS

Caple tumble dryers use state-of-the-art technology to make every task effortless.



Our fully integrated tumble dryers offer two heat settings and a venting system for the best possible performance. The TDi111 also has sensors in the drum that constantly check moisture levels, so the machine only stops when clothes are completely dry. Other handy features include a reverse tumble action, six levels of dryness and an easy-access fluff filter.

FULLY INTEGRATED SENSOR VENTED TUMBLE DRYER



PRODUCT CODE

TDi111

DIMENSIONS

↔ w:600mm

PERFORMANCE

e Energy Class C
Est. annual energy consumption 519kWh/yr
Average energy by cycle 4.39kWh
Max. noise level 62dB

FINISH AVAILABLE

White

OPTIONS

6 **Sensor drying levels**
Extra dry
Cupboard dry
Mid dry
Extra iron dry
Iron dry
Damp dry

FEATURES

- Vented drying
- 2 Heat settings
- 30 minute timed drying with heat
- 30 minute refresh
- Reverse tumble action
- Final cool down tumble
- Easy access fluff filter
- Rear vented only
- Integral extendable 2.4m hose and wall outlet
- Reversible appliance and furniture door
- Adjustable legs

CAPACITY

- 7kg drying capacity

INSTALLATION

- Diagram [p.267]
- Electrical connection
- Rated load 2.7kW
- Fuse rating 13A

FULLY INTEGRATED VENTED TUMBLE DRYER



PRODUCT CODE

TDi101

DIMENSIONS

↔ w:600mm

PERFORMANCE

e Energy Class C
Est. annual energy consumption 459kWh/yr
Max. noise level 62dB

FINISH AVAILABLE

White

FEATURES

- Vented drying
- 2 Heat settings
- Reverse tumble action
- Final cool down tumble
- Easy access fluff filter
- Rear vented only
- Integral extendable 2.4m hose and wall outlet
- Reversible appliance and furniture door
- Adjustable legs

CAPACITY

- 6kg drying capacity

INSTALLATION

- Diagram [p.267]
- Electrical connection
- Rated load 2.7kW
- Fuse rating 13A

PLINTH HEATERS



PRODUCT CODE
PH500H

DIMENSIONS

Grille: 495 x 100mm
Heater: 320 x 400mm
[including pipe work] Plinth
cut out: 360 x 96mm

FUNCTIONS

- 500mm hydronic plinth heater [central heating]
- Stainless steel grille
- 2 speed fan
- Summer setting [fan circulates air round the room]
- Up to 24% more efficient than standard radiators
- Auto switch on
- Easy install
- Low noise

CONNECTIONS

- Fuse rating: 3amp
- Voltage: 220-240 / 50hz
- Heat output: 3057 - 3979 Btu [0.9 - 1.17kW]
- Maximum working pressure: 8bar [1Mpa]

OPTIONAL EXTRAS

- White plinth grille available [PHHGRILL/WH]

Visit caple.co.uk for full range

PRODUCT CODE
PH500E

DIMENSIONS

Grille: 495 x 100mm
Heater: 320 x 200mm
Plinth cut out:
360 x 96mm

FUNCTIONS

- 500mm electric plinth heater
- Stainless steel grille
- 2 speed fan
- Easy install
- Low noise

CONNECTIONS

- Fuse rating: 10amp
- Voltage: 220-240 / 50hz
- Heat output: 940 -1990w

OPTIONAL EXTRAS

- White plinth grille available [PHHGRILL/WH]

Visit caple.co.uk for full range

Features

WHITE GRILLE

Optional extra plinth grille finished in white.

PHEGRILL/WH
PHHGRILL/WH



FOOD WASTE DISPOSAL

A waste disposer hidden away under the sink can help you recycle your food scraps and leftovers like potato peelings, chicken bones, egg shells and tea bags. It's clean, it's green and it leaves less to clutter up your bin. It also reduces any decomposing food odours.



It couldn't be easier or more convenient to use. Simply turn on the cold tap and the disposer then empty everything into the sink. The disposer grinds the food waste into fine particles and flushes the waste away down the drain.



Since more than 25% of household refuse is food, that means much less rubbish to take away and clog up our landfill sites. It also means a reduction in the amount of greenhouse gases emitted. Waste from your disposer can actually be recycled into a soil conditioner once it reaches the water treatment plant, so you will be making a positive contribution to your environment.

FOOD WASTE DISPOSAL UNITS



PRODUCT CODE
WDU050

DIMENSIONS
 w:175mm
 d:175mm
 h:372mm

FEATURES

- 0.5hp waste disposal unit
- Continuous feed
- High speed magnet motor
- Overload protection
- Corrosion resistant 3 stage grinding system
- Easy mount installation
- Sound insulation
- 2 Year guarantee
- Suitable for air switch [WDAIR - see opposite]

OPTIONAL EXTRAS

- Air switch [WDAIR] for WDU050 only
- Basket strainer waste decorative cover [CWC2]
- Visit cople.co.uk for full range

PRODUCT CODE
WDU075

DIMENSIONS
 w:216mm
 d:216mm
 h:400mm

FEATURES

- 0.75hp waste disposal unit
- Continuous feed
- High speed magnet motor
- Overload protection
- Corrosion resistant 3 stage grinding system
- Easy mount installation
- Sound insulation
- 2 Year guarantee
- Air switch [WDAIR] included

OPTIONAL EXTRAS

- Basket strainer waste decorative cover [CWC2]
- Visit cople.co.uk for full range

PRODUCT CODE
WDU100

DIMENSIONS
 w:216mm
 d:216mm
 h:437mm

FEATURES

- 1.0hp waste disposal unit
- Continuous feed
- High speed magnet motor
- Overload protection
- Corrosion resistant 3 stage grinding system
- Easy mount installation
- Sound insulation
- 3 Year guarantee
- Air switch [WDAIR] included

OPTIONAL EXTRAS

- Basket strainer waste decorative cover [CWC2]
- Visit cople.co.uk for full range

Features

WDAIR

The chrome air switch is an optional extra with the WDU050 and comes as standard with the WDU075 and WDU100.



WDAIR



CWC2

INSTALLATION DIAGRAMS

SINGLE OVENS
C2481SS

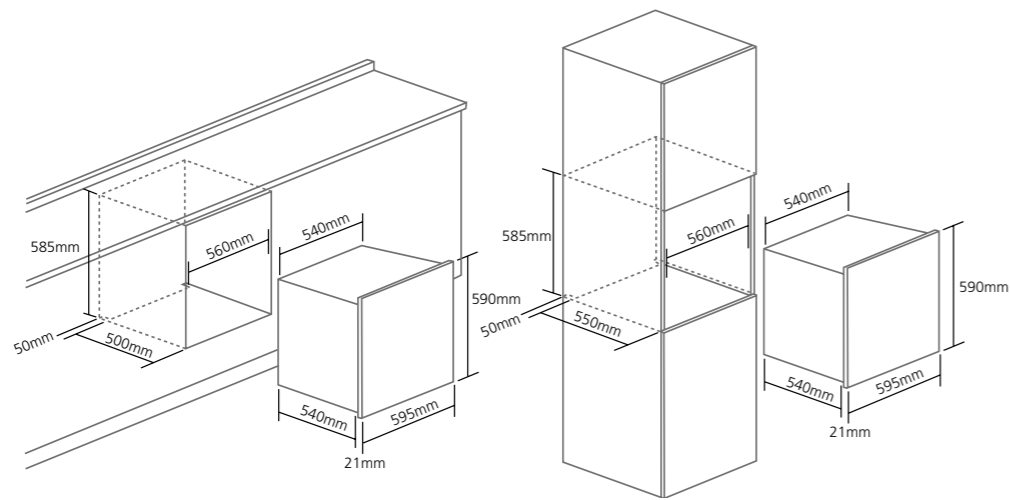

C2161SS / C2151SS / C2150WH

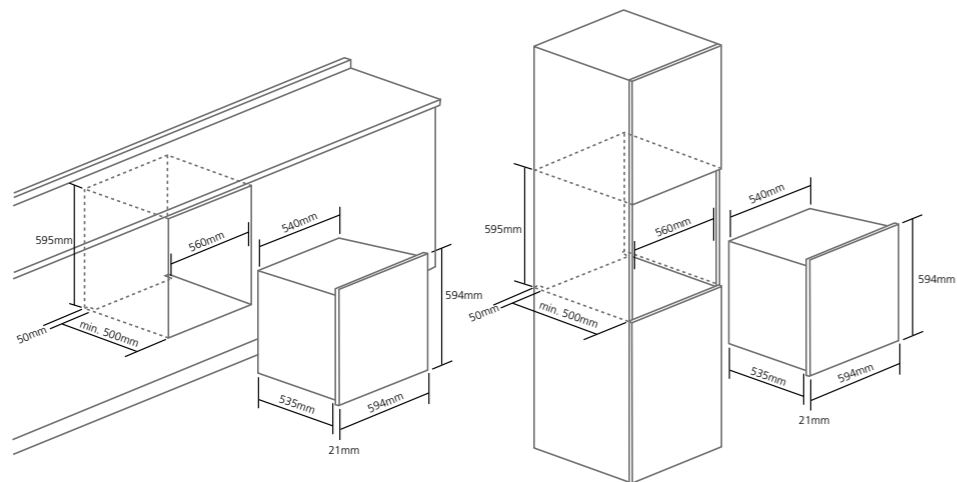

SINGLE OVENS
C2901

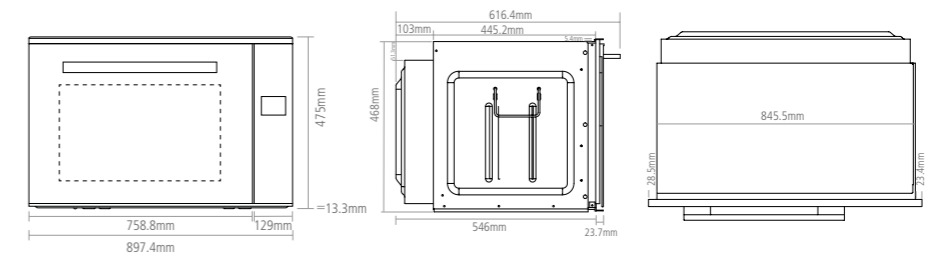
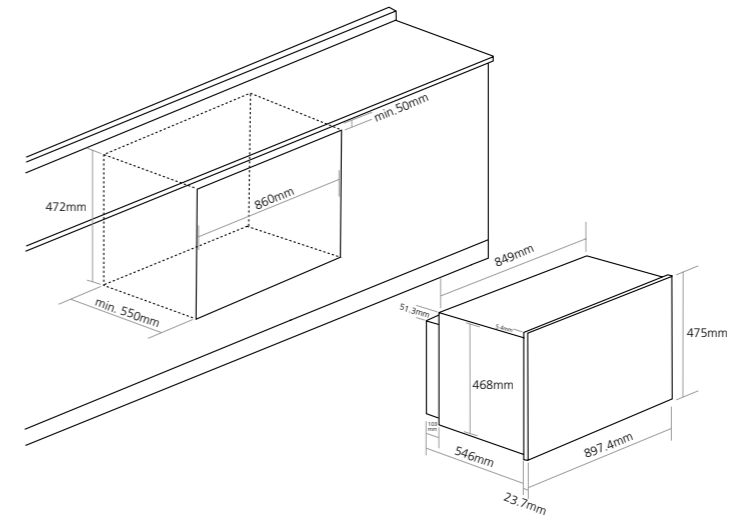

C2401 / C2105 / C2101 / C2362

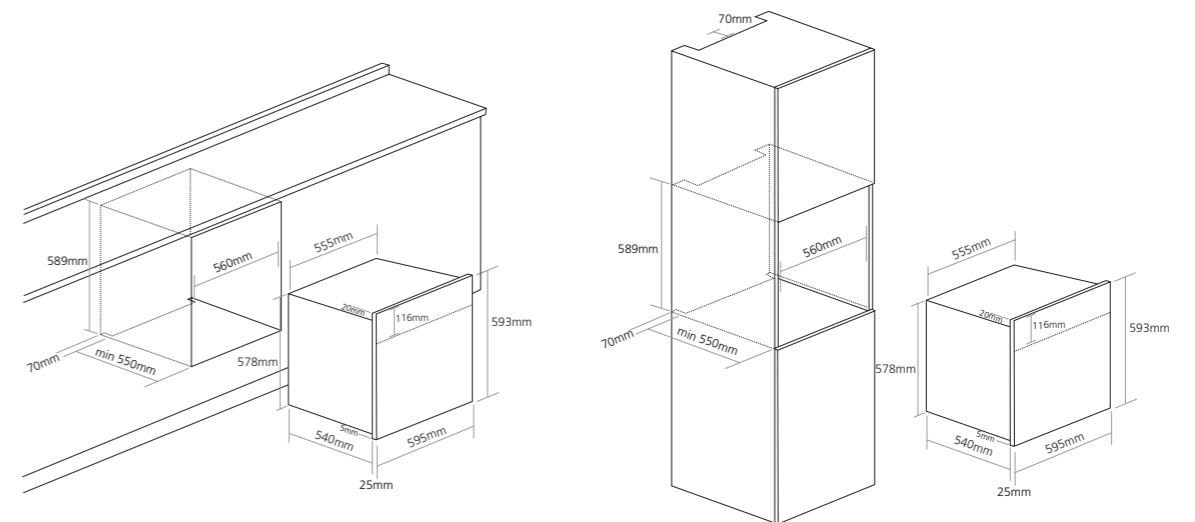

We recommend that when installing a stack or quad of products, a pair of our installation brackets [OVEN/BRACKETS] are purchased to support the upper product ensuring a seamless fit for each appliance when one is on top of the other.

We recommend that when installing a stack or quad of products, a pair of our installation brackets [OVEN/BRACKETS] are purchased to support the upper product ensuring a seamless fit for each appliance when one is on top of the other.

SINGLE OVENS

C2219

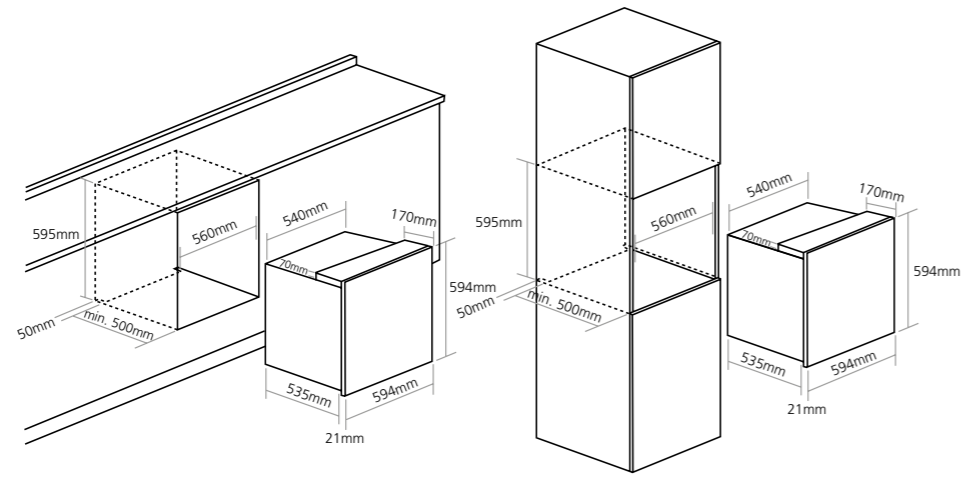

C2238 / C2236 / C2233 / C2233BK / C2230

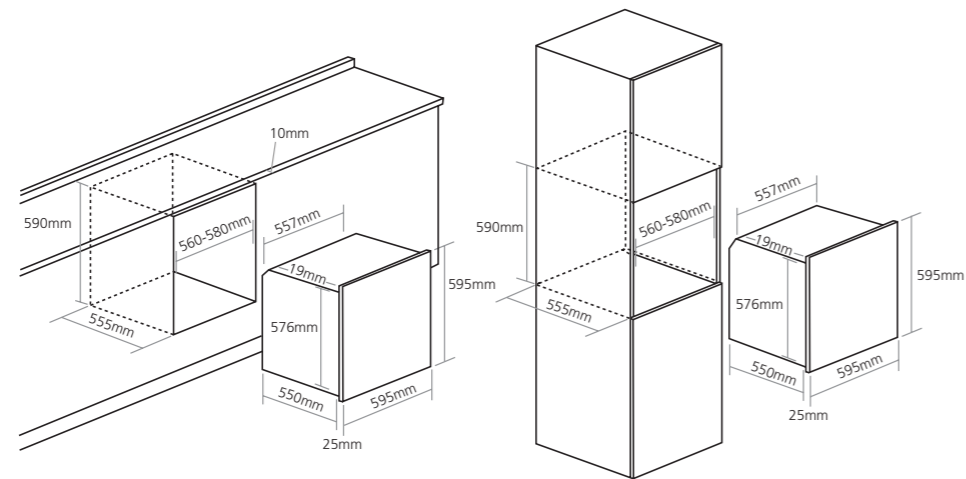

C2512

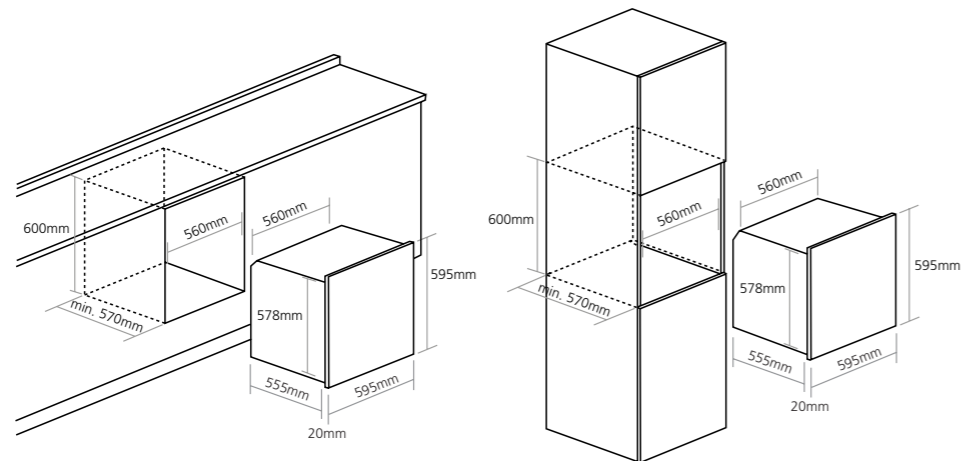

DOUBLE OVENS

C3371 / C3248 / C3245

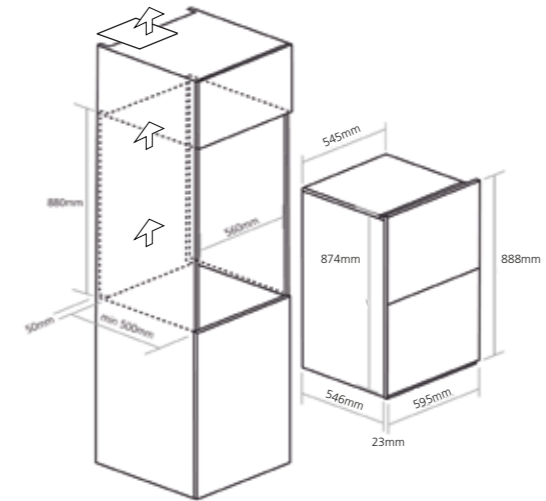

BUILT-UNDER DOUBLE OVENS

C4360

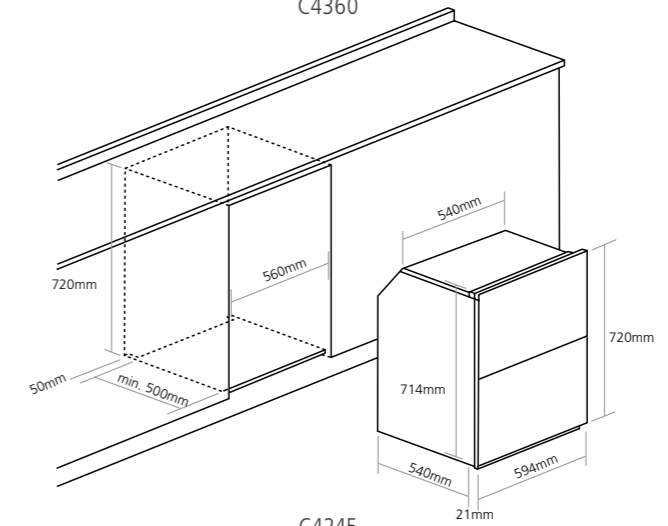

C4245

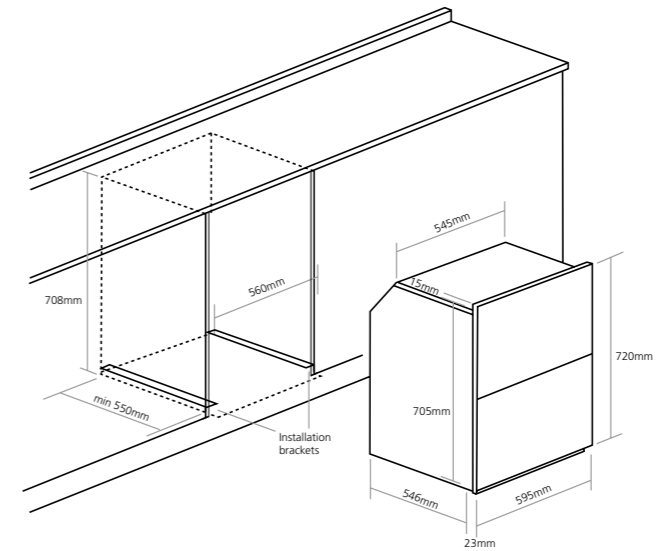

We recommend that when installing a stack or quad of products, a pair of our installation brackets [OVEN/BRACKETS] are purchased to support the upper product ensuring a seamless fit for each appliance when one is on top of the other.

We recommend that when installing a stack or quad of products, a pair of our installation brackets [OVEN/BRACKETS] are purchased to support the upper product ensuring a seamless fit for each appliance when one is on top of the other.

STEAM OVENS

SO210SS / SO209WH

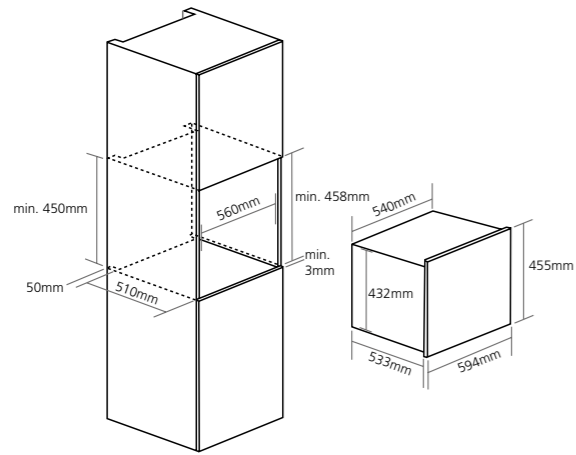

SO110

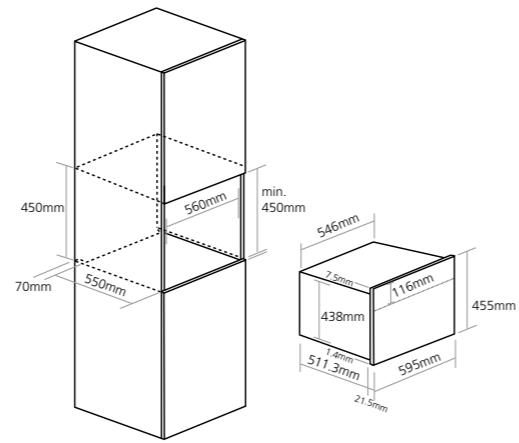

MICROWAVES

CM119

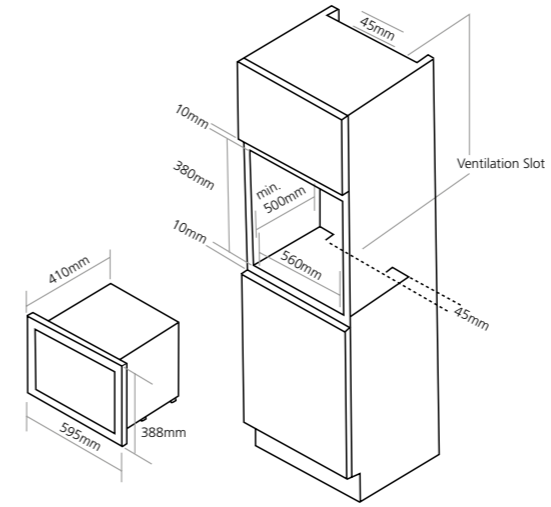

CM126

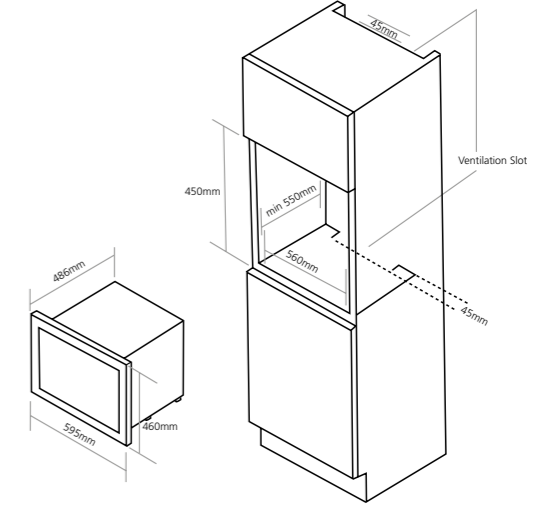

MICROWAVES

CM210SS / CM209WH

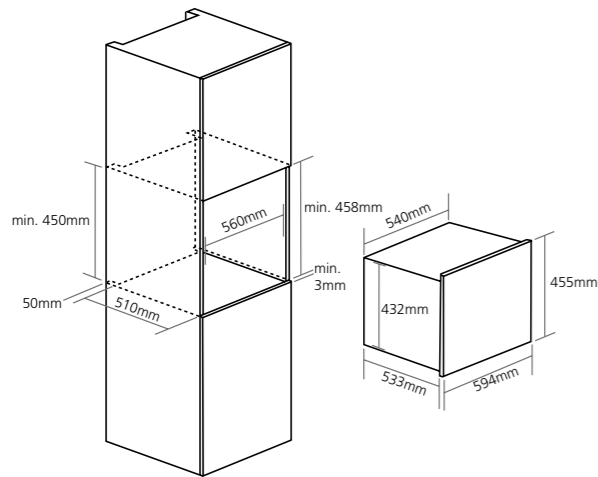

CM110 / CM108

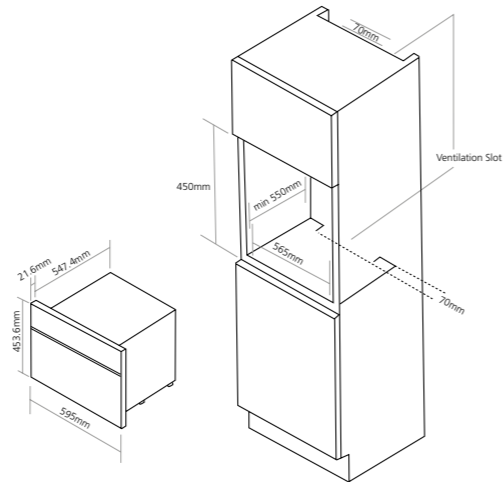

CM120

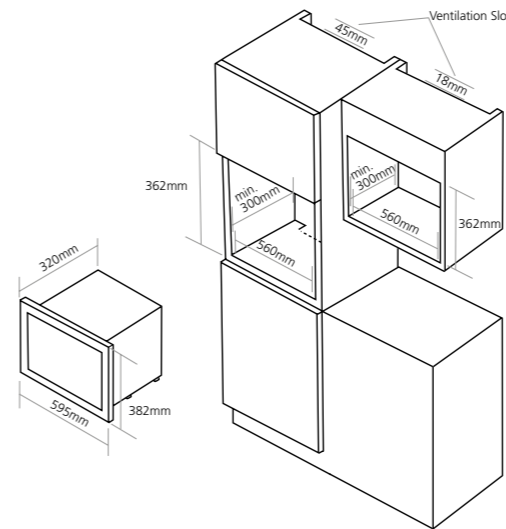

CM123 / CM123BK

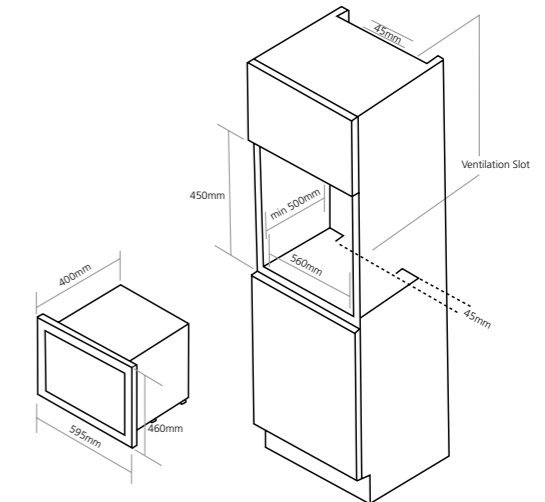

CM140

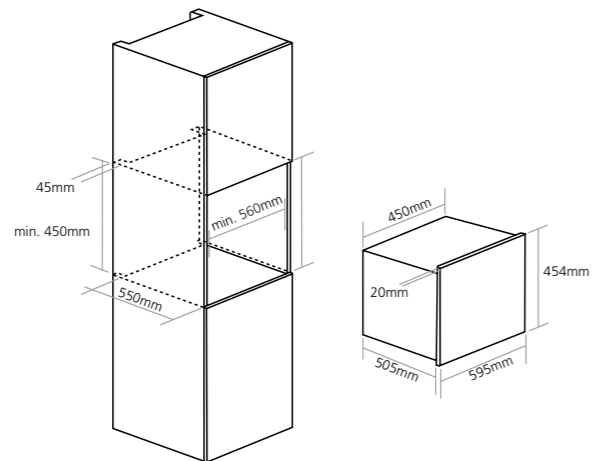

COFFEE MACHINES

CM471SS / CM471WH

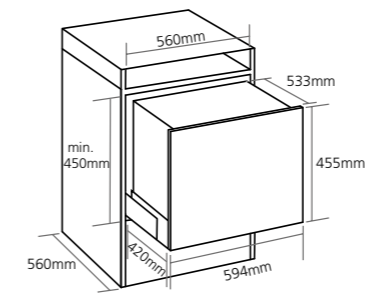

CM465

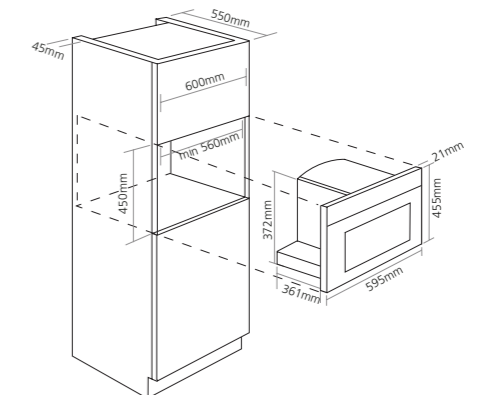

We recommend that when installing a stack or quad of products, a pair of our installation brackets [OVEN/BACKETS] are purchased to support the upper product ensuring a seamless fit for each appliance when one is on top of the other.

We recommend that when installing a stack or quad of products, a pair of our installation brackets [OVEN/BACKETS] are purchased to support the upper product ensuring a seamless fit for each appliance when one is on top of the other.

WARMING DRAWERS

WD140BK

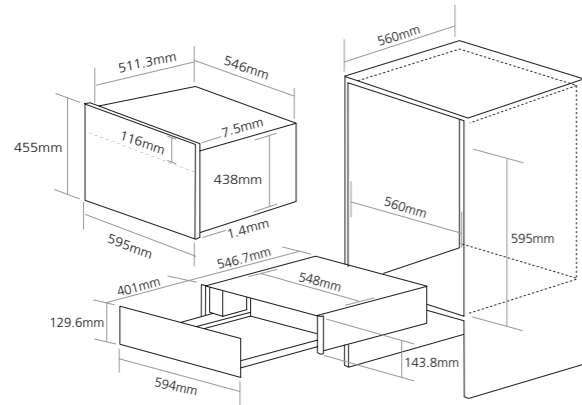

WMD1356 / WMD1355WH

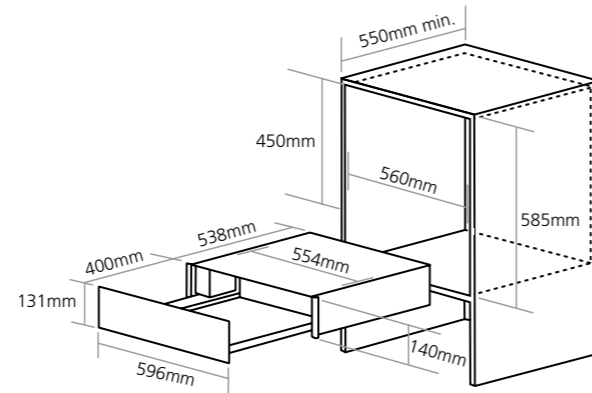

WMD2954

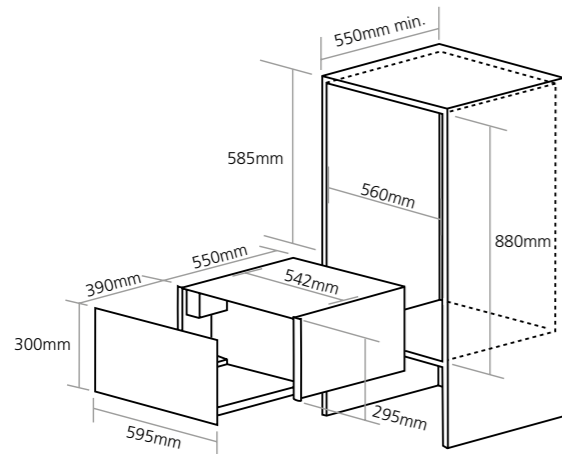

WMD1354

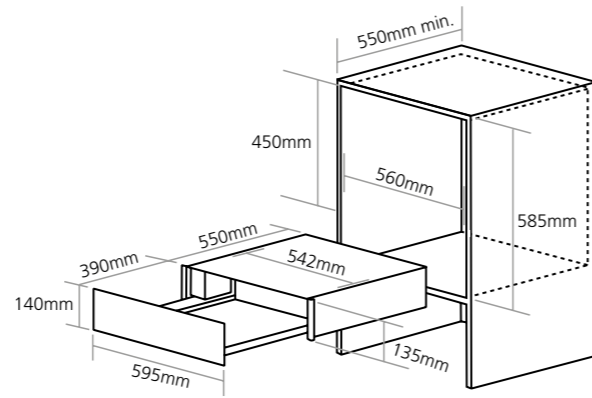

STORAGE DRAWER

SD1356

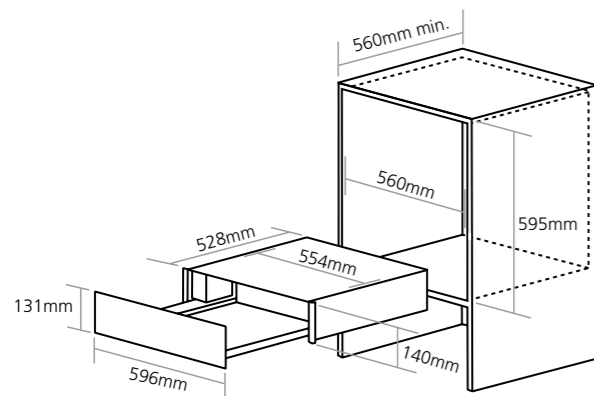

RANGE COOKERS

CR9228 / CR9209 / CR9111 / CR9109

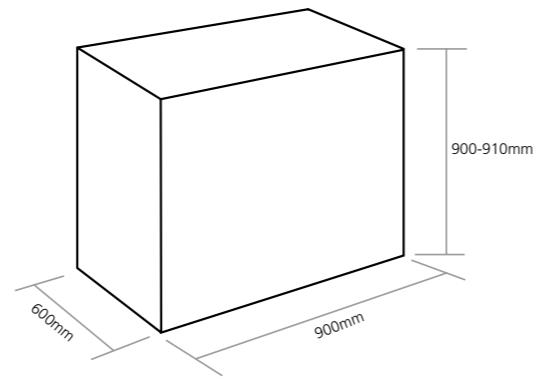

INDUCTION HOBS

C970i

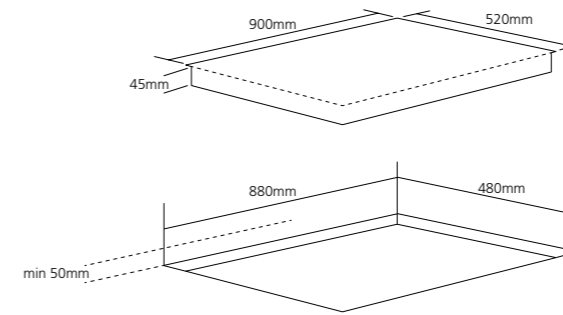

C896iBK

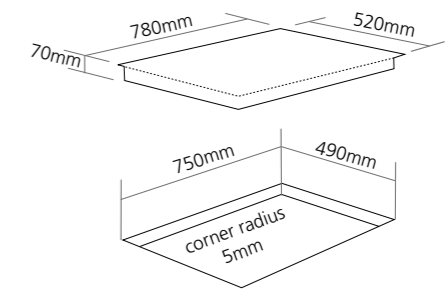

C895iWH

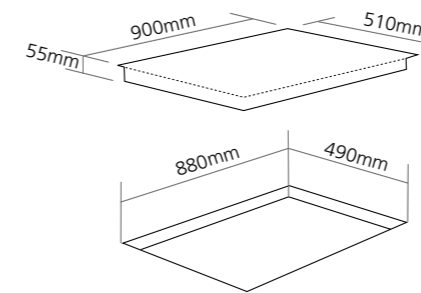

C875i

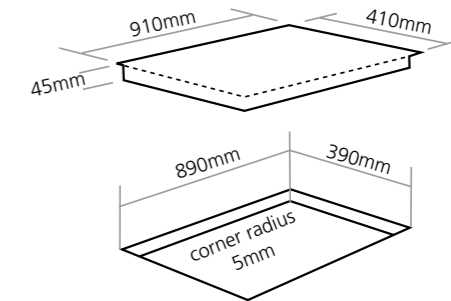

A minimum ventilation of 100cm² is required

C900i

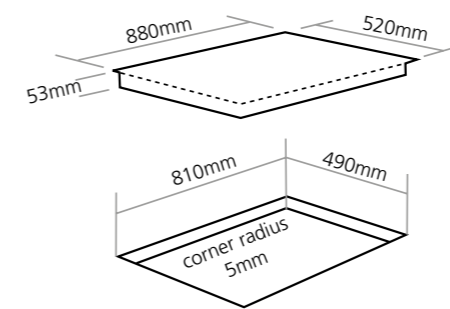

C867i

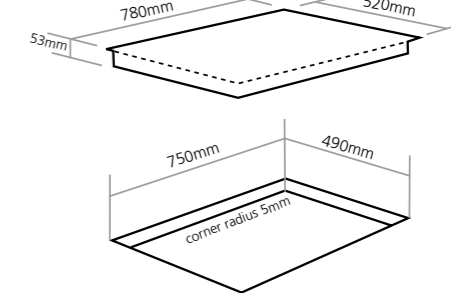

A minimum ventilation of 100cm² is required

C950i

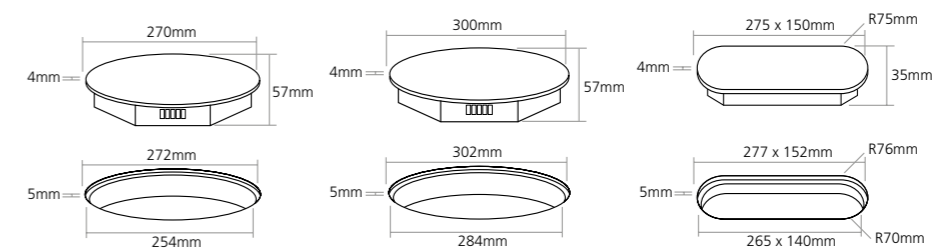

Induction hobs C950i - All 4 zones must be installed.

Induction hobs C950i, C875i, C900i, C970i and C867i:

A minimum gap of 20mm is required beneath the hob fans, and a 4mm gap must be left under the worktop at the front of the hob for ventilation.

INDUCTION HOBS

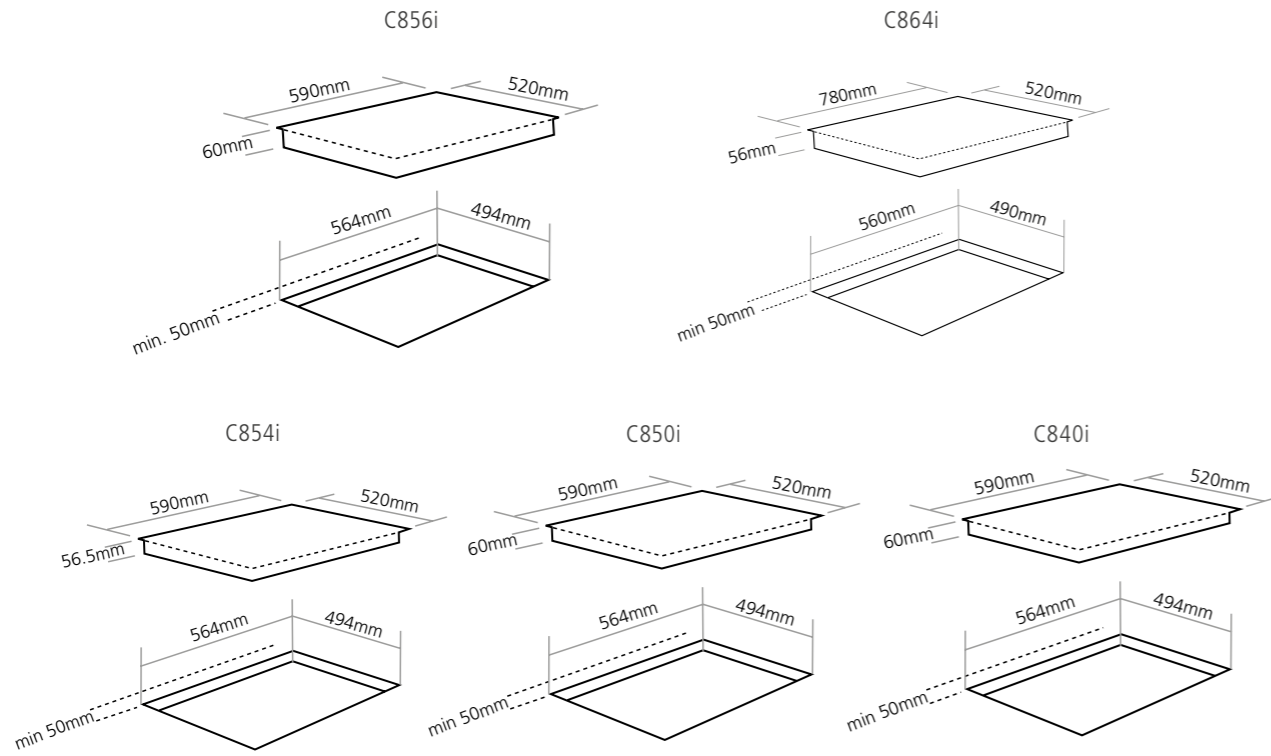

Induction hobs C856i, C864i, C854i, C850i and C840i:
 A minimum gap of 50mm required beneath the hob fans, and a 5mm gap must be left under the worktop at the front of the hob for ventilation.

ELECTRIC HOBS

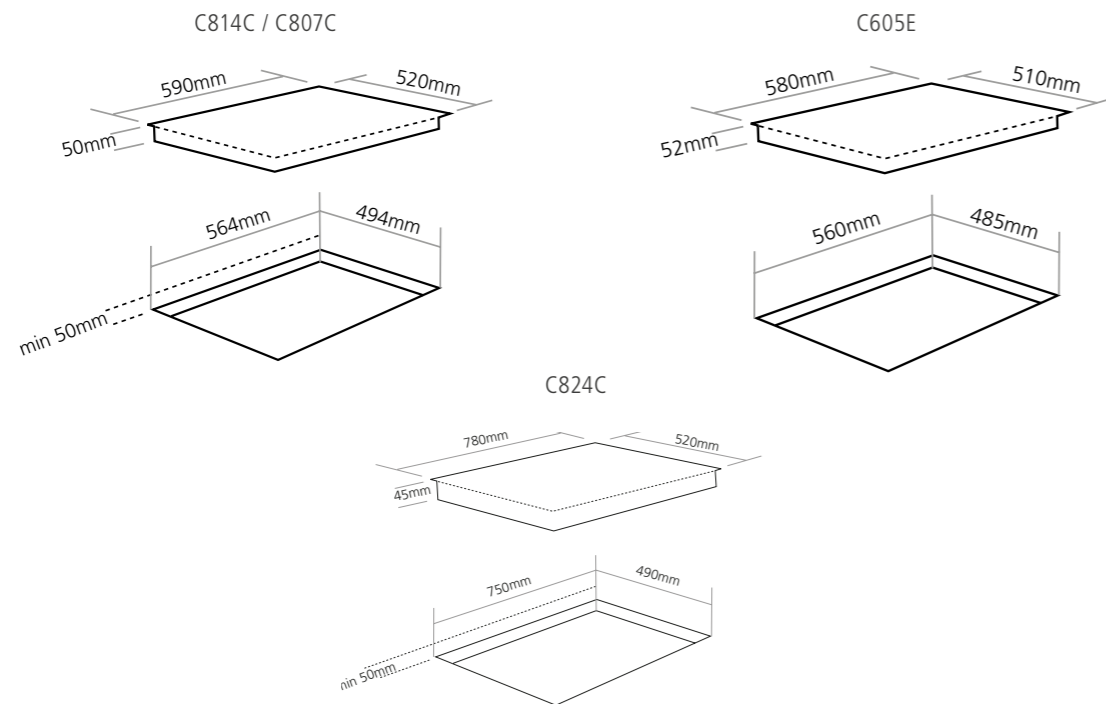

GAS HOBS

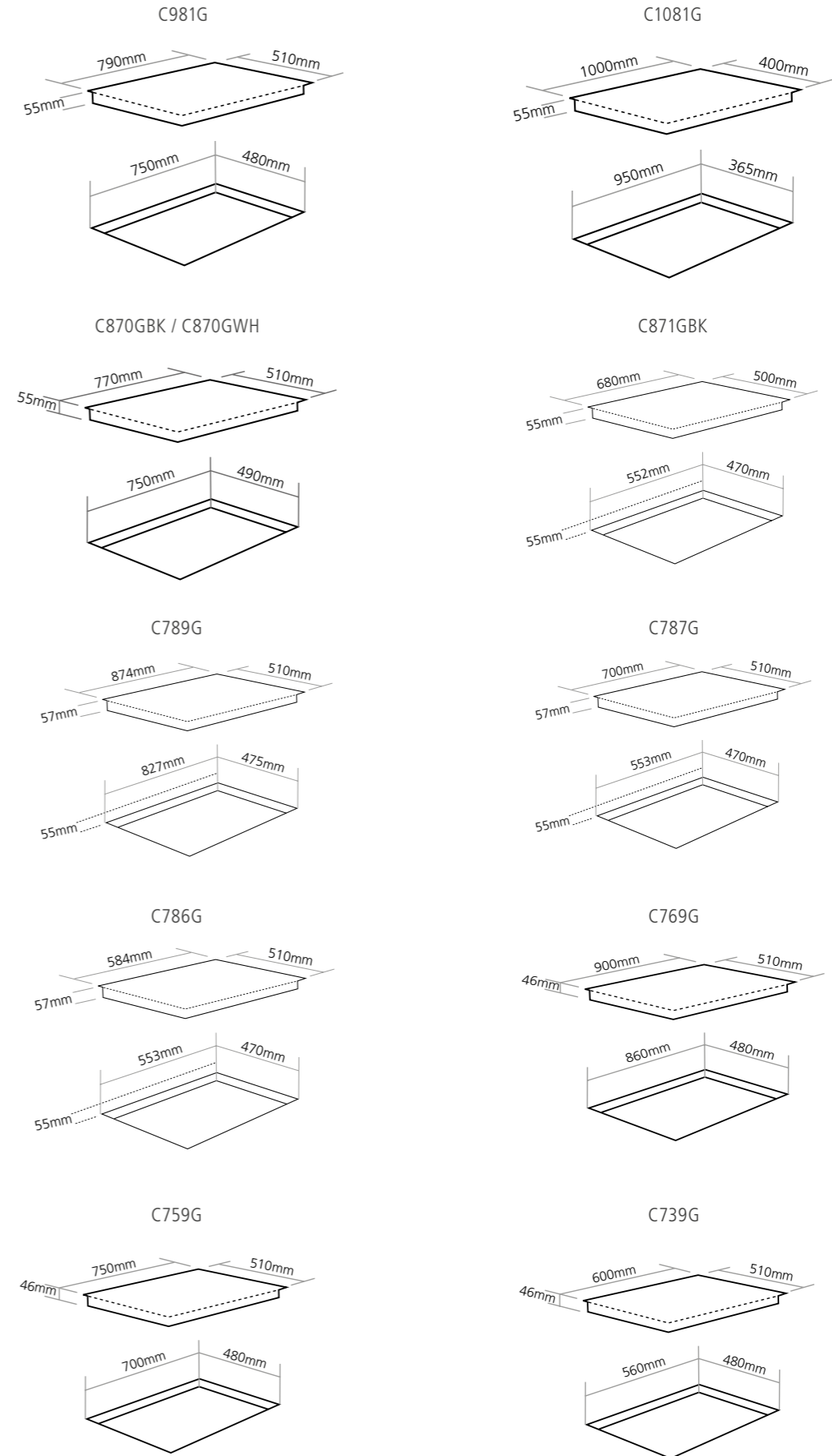



GAS HOBS

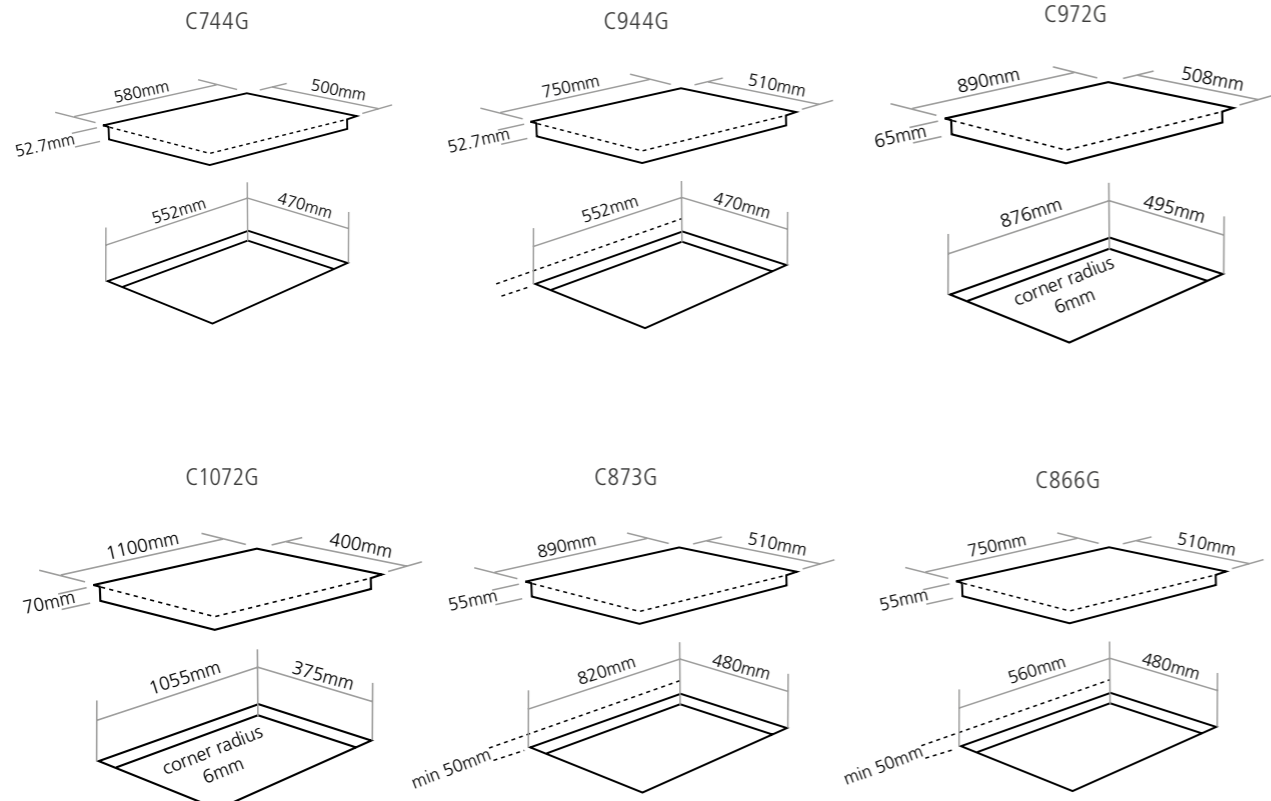

MODULAR HOBS

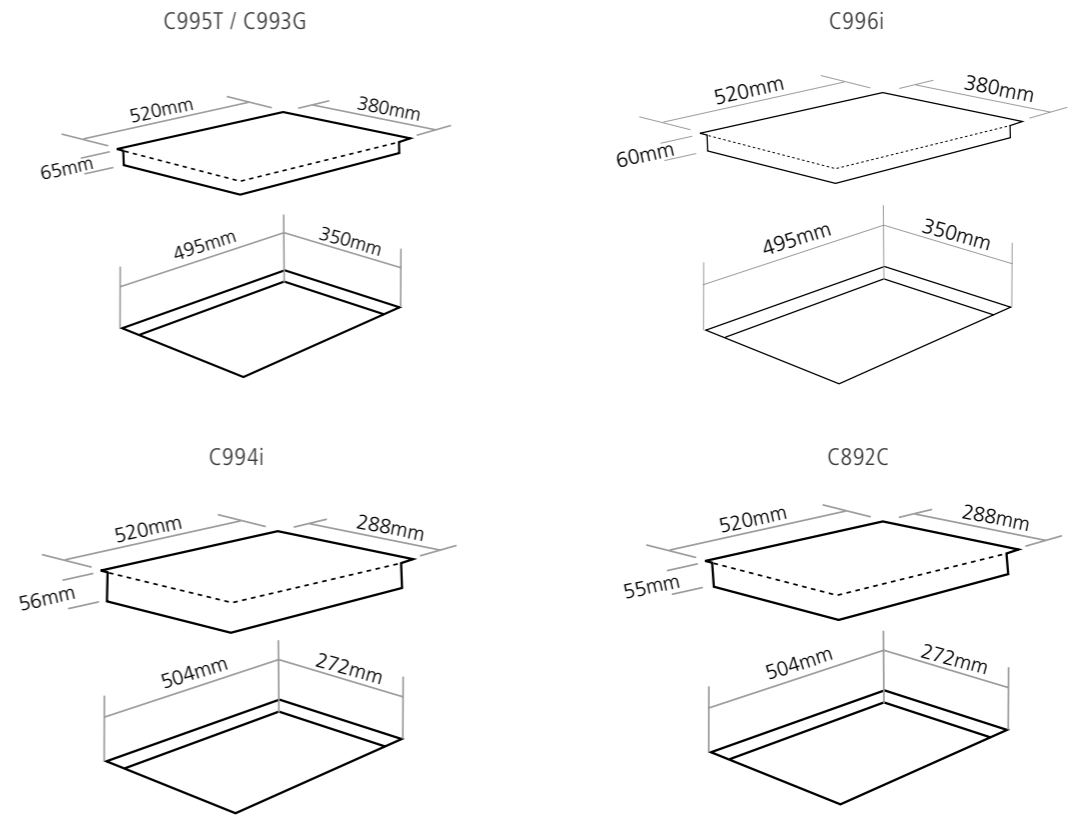

If installed without a gap in between, cut-out width = [no. of hobs - 1] x 288mm] + 268mm

INDUCTION DOWNDRAFT HOB

DD940BK

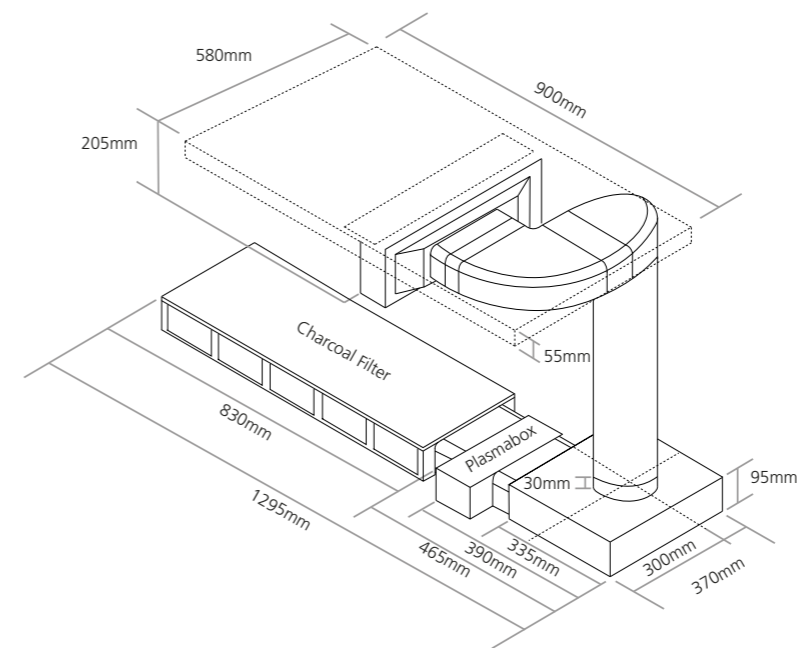

INSTALLATION

Example A

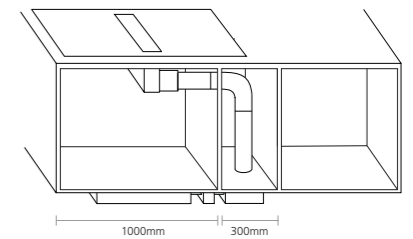

Example B

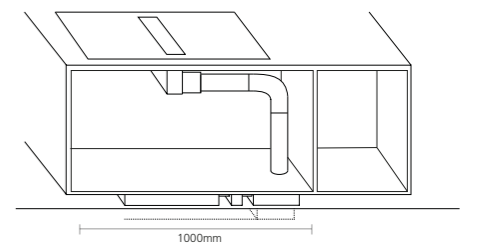



INDUCTION DOWNDRAFT HOB

DD935BK

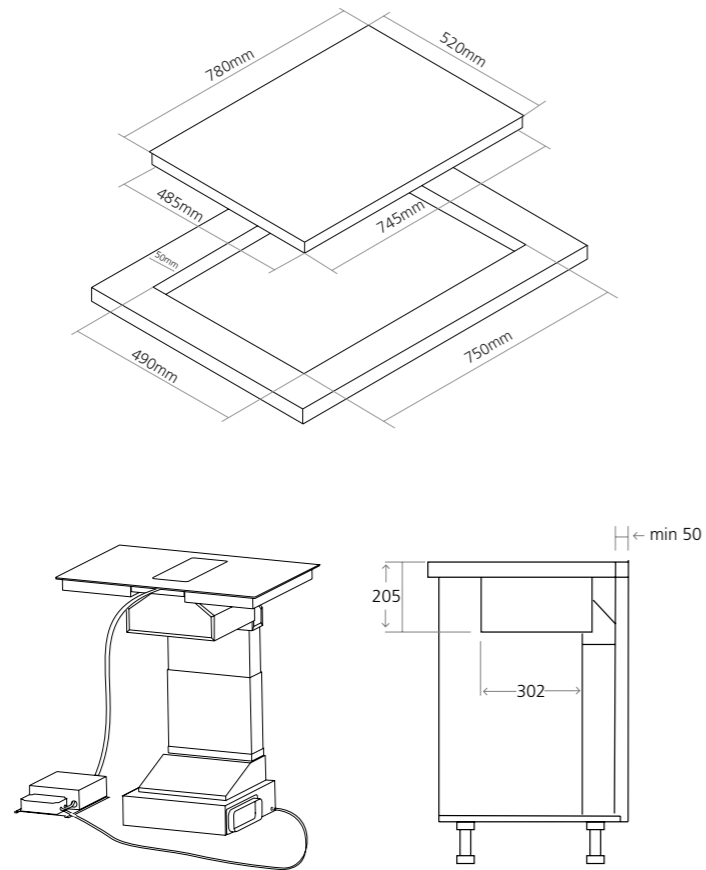

DOWNDRAFT EXTRACTORS

DD120BK

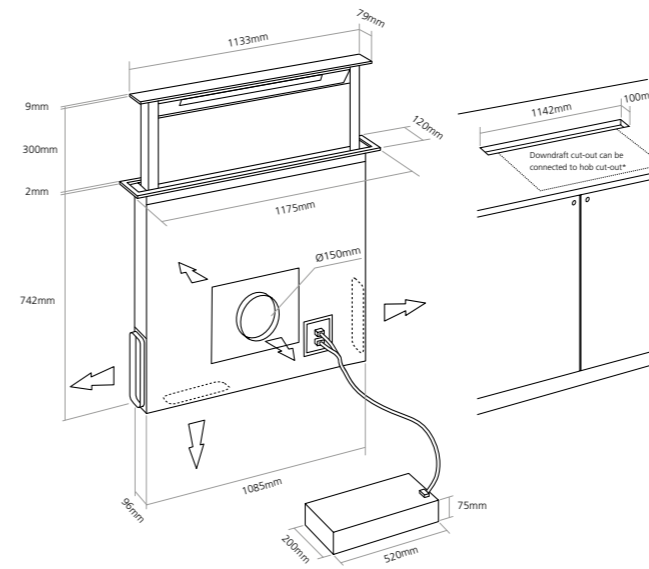

DD925CO

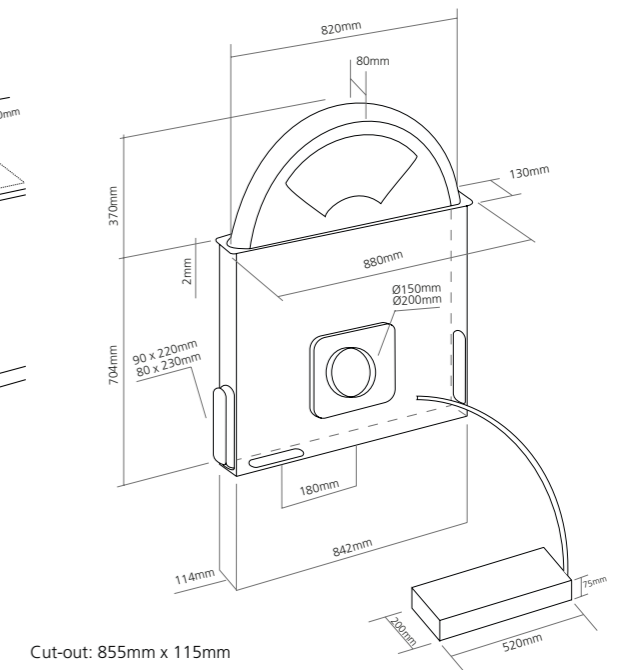

Cut-out: 855mm x 115mm

DD931BK

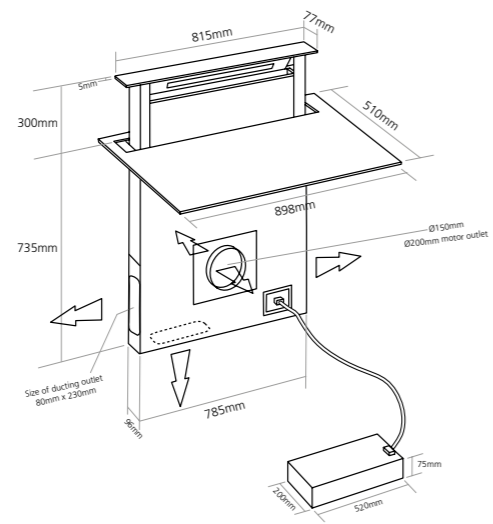

DD921BK

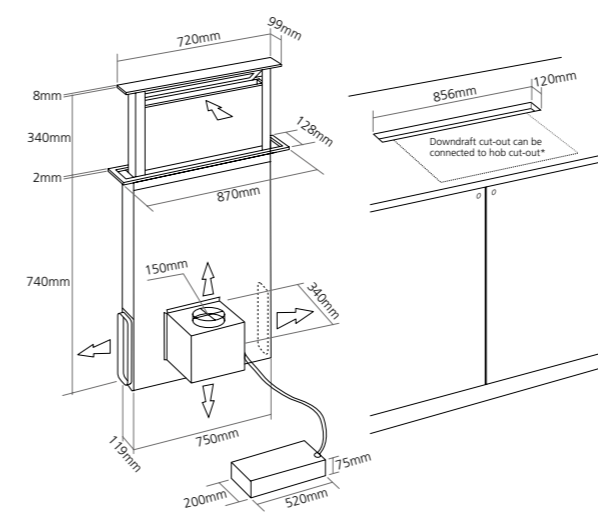

DD911SS / DD911WH / DD911BK

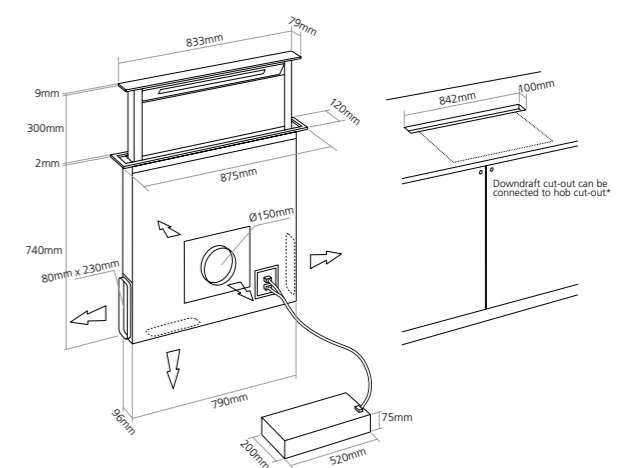

*For electric hobs only. A 50mm gap is required for gas hobs.



DOWNDRAFT EXTRACTORS

DD901BK

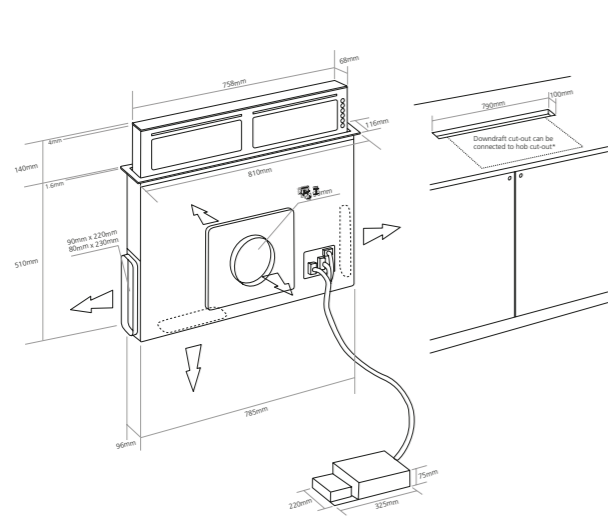

DD522BK

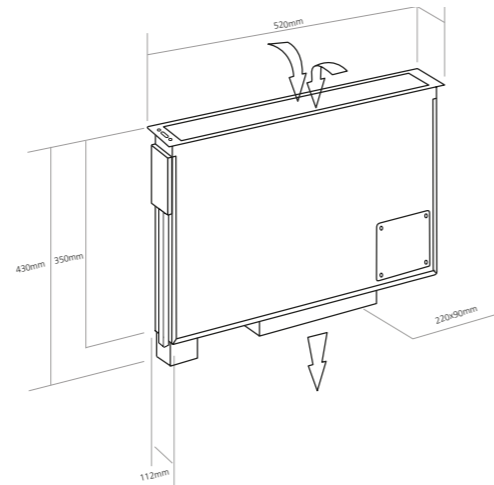

DD606SS / DD606BK

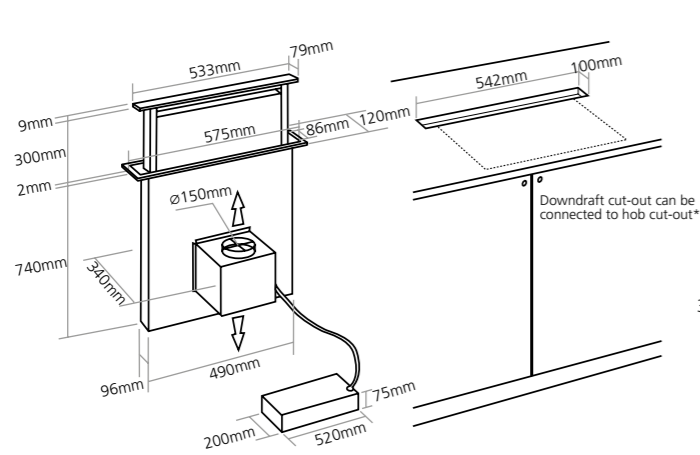

DD903BK

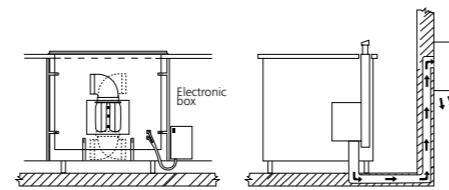
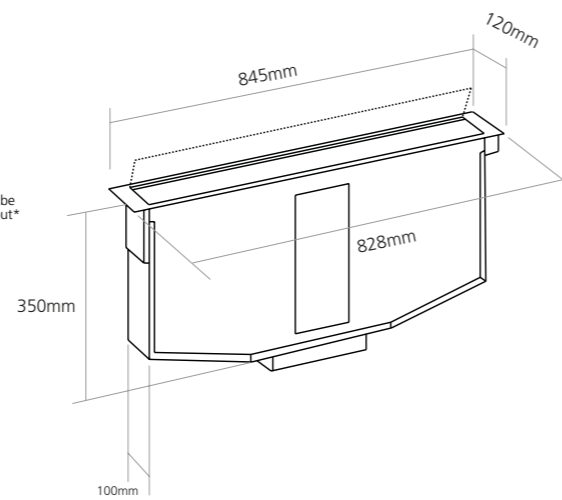

INSTALLATION MADE EASY

Minimum cabinet depth depends on orientation, hob type and worktop material.

Cabinet base may need to be cut or routed to accommodate height of unit.

If positioned behind a hob, minimum cabinet width for DD522/606 extractors is 600mm, for DD903/911/921 allow 900mm and for DD120BK 1200mm is required.

If positioned alongside a hob, the cabinet may need to be reinforced to strengthen where the base has been modified.

The hood can be fitted right up to an electric hob [50mm gap required for gas hobs], but always ensure that the independent electronics box in the cupboard below is installed at least 650mm from the heat source.

The hood can be ducted from both sides enabling the downdraft to be positioned behind a hob and under-counter oven.

*For electric hobs only. A 50mm gap is required for gas hobs.

CEILING HOODS

CE1000

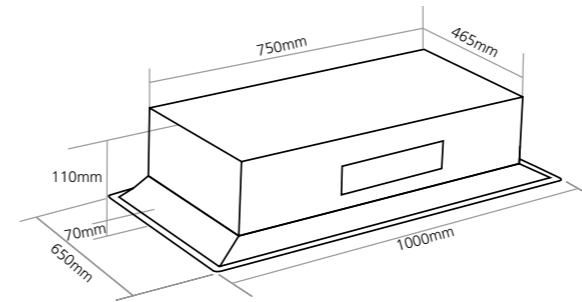

CE1122SS/CE1121

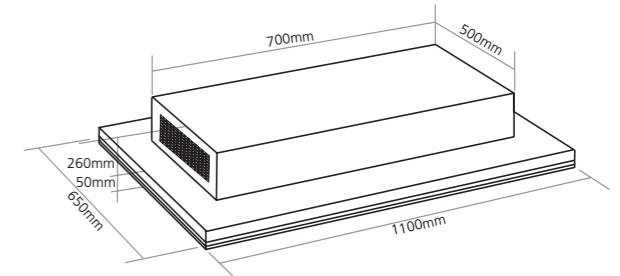

Minimum build in depth 215mm

CE1101

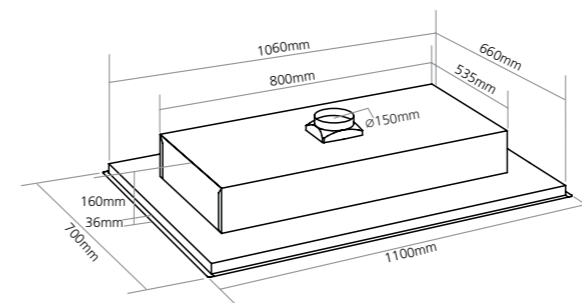

Minimum build in depth 270mm

CE902SS / CE902WH

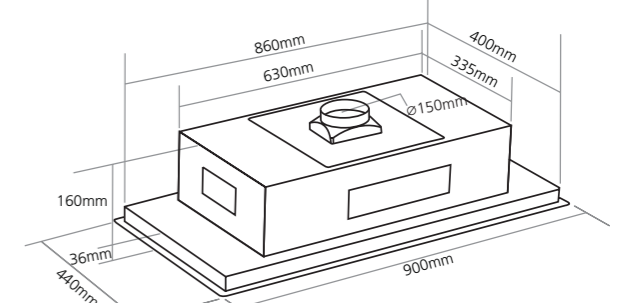

Minimum build in depth 270mm

EXTRACTION MOTORS

DDMEXT11

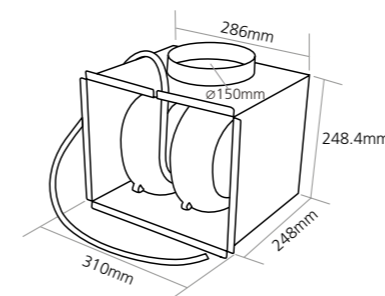

DDMEXT21

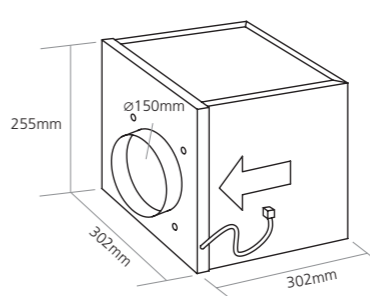

DDMEXT25

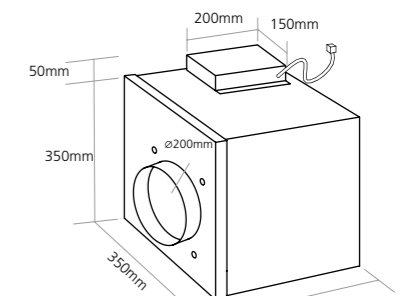

DDMEXT28

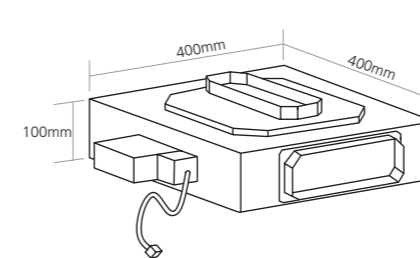

DDMEXT30

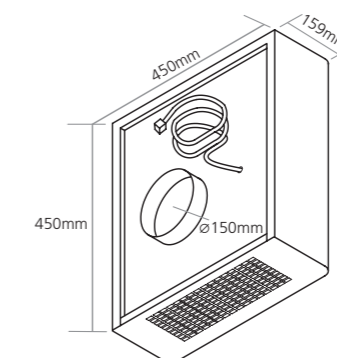

DDMEXT40

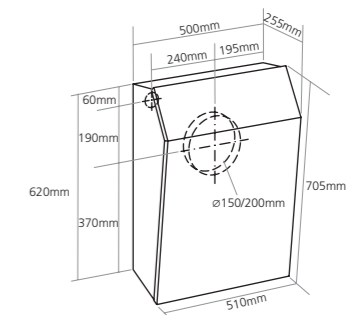

ISLAND HOODS

CR700 / CR700WH / CR700SL

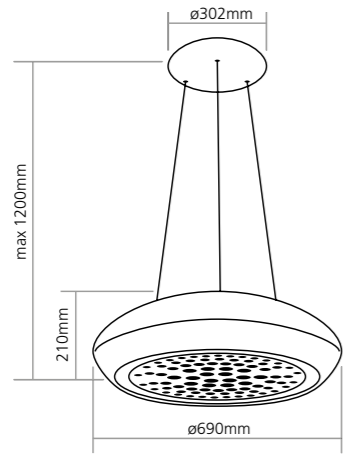

CR750CO / CR750WH / CR750SL

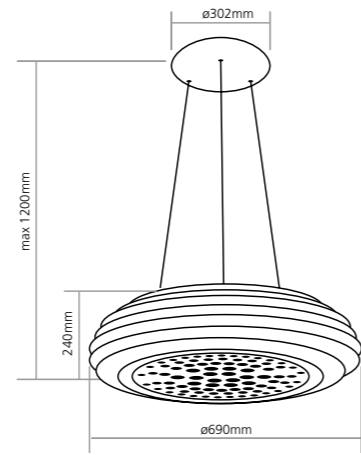

ZAL48SL / ZAL48CO / ZAL48BK

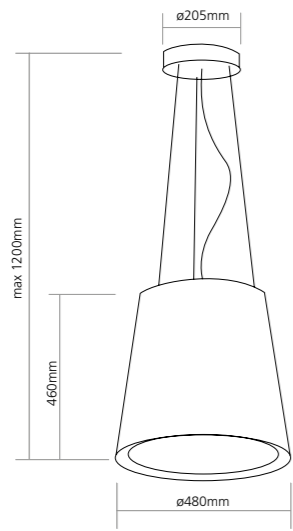

Pi402

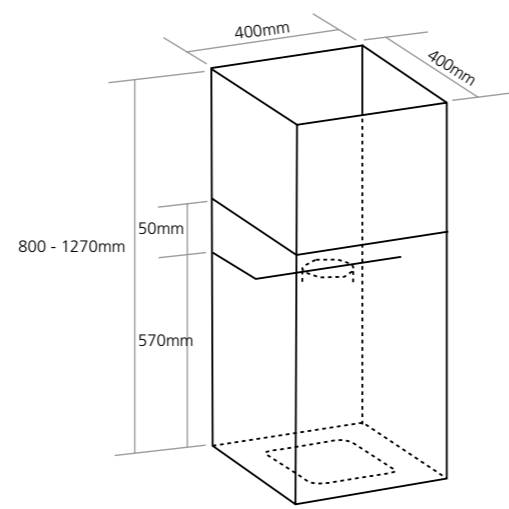

ISLAND HOODS

Zi922

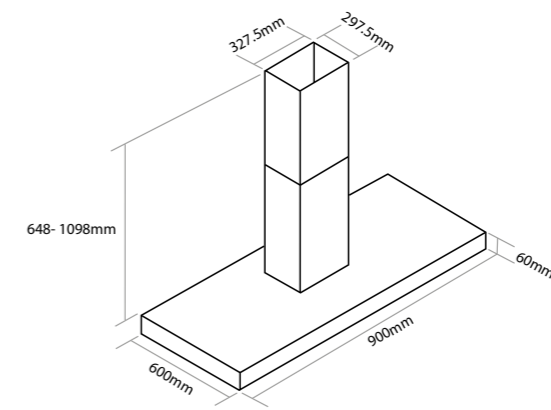

CGi921

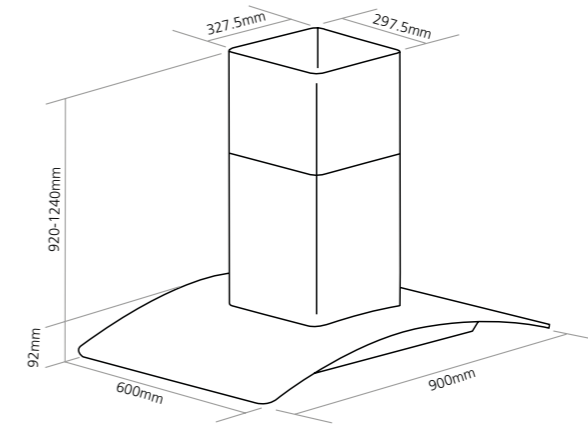

Oi363

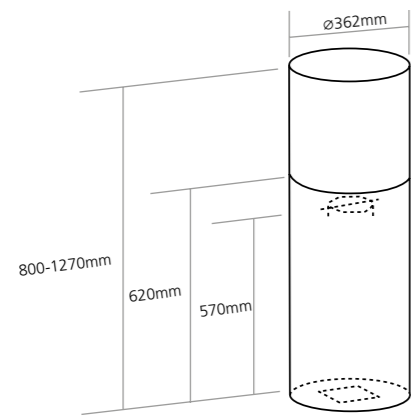

BXi911

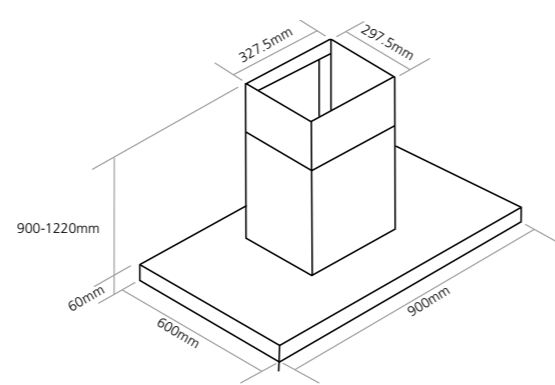

CGi920/RED

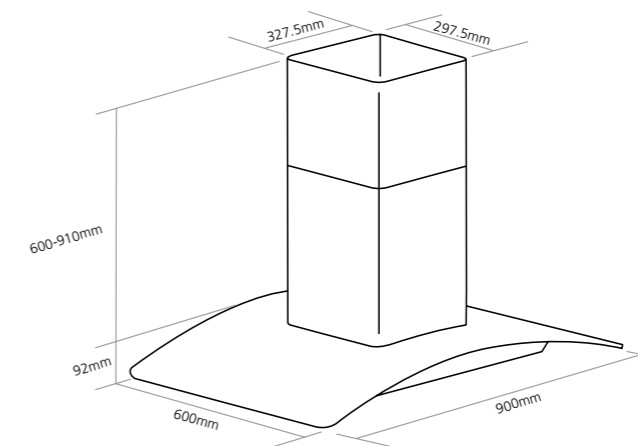

Note: Suitable to be installed in a standard room height of 2.3m

WALL CHIMNEY HOODS

MOT912

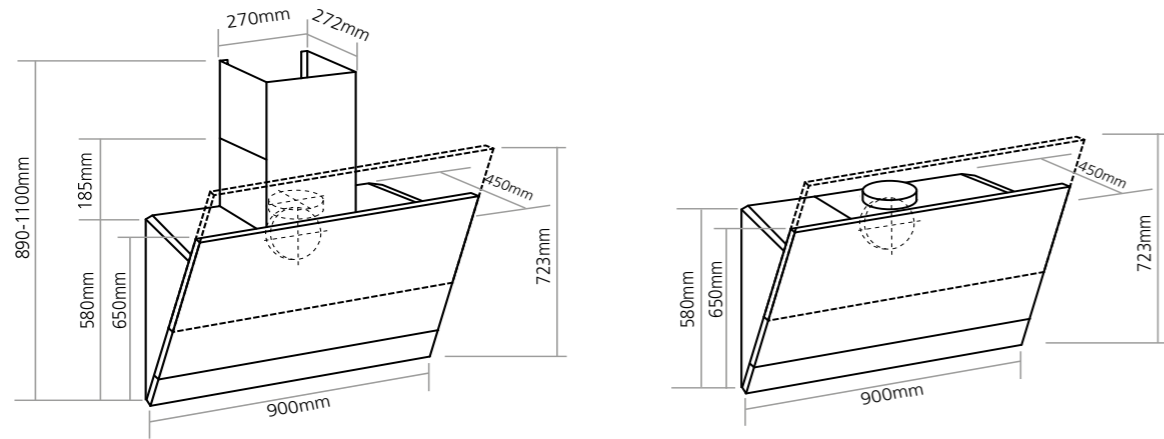

WALL CHIMNEY HOODS

ZZ801

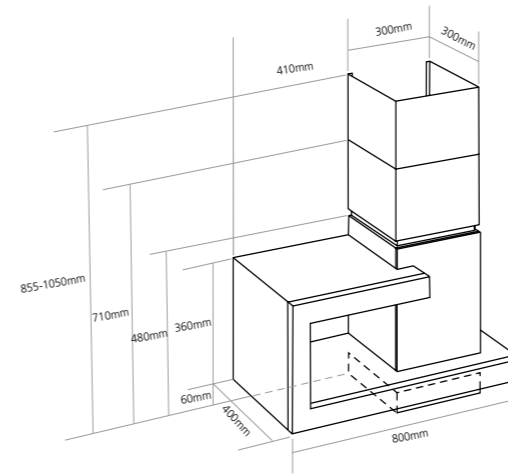

ZC922

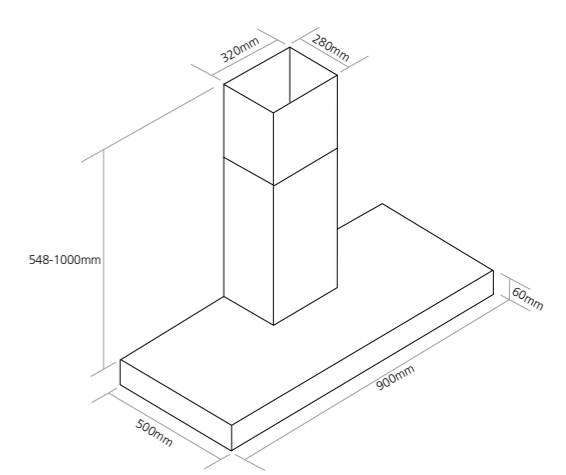

OM600

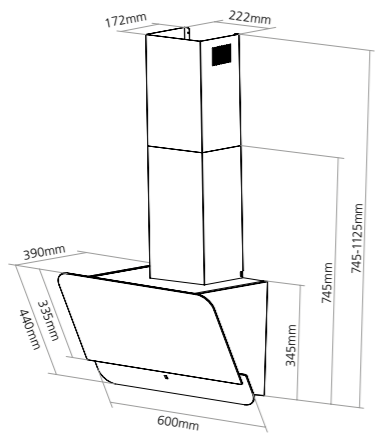

OM900

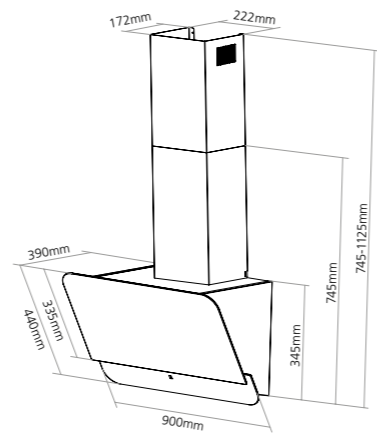

ZC622

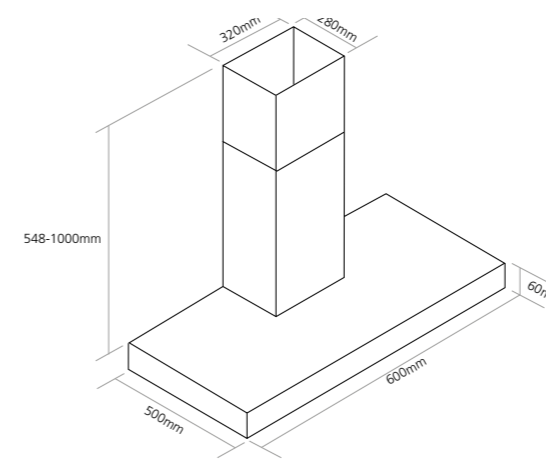

FGC920 / FGC720 / FGC620

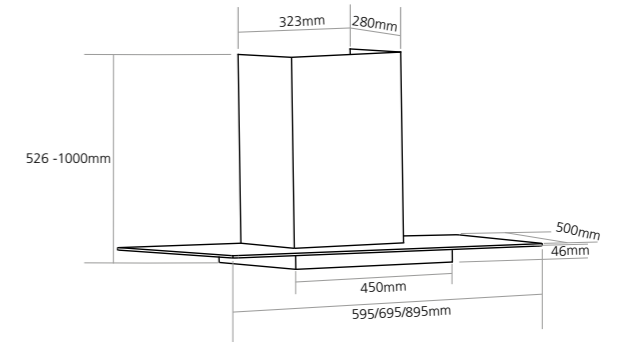

AS911BK / AS611BK

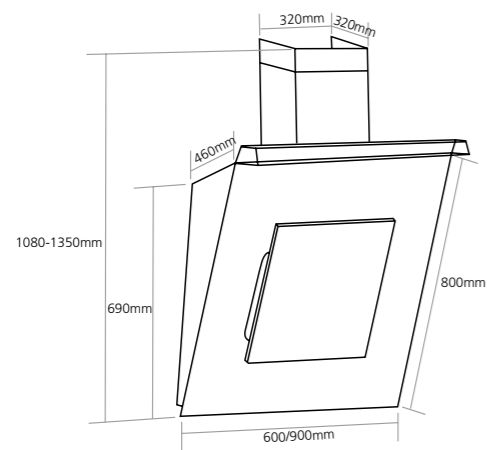

SP911BK / SP911SS / SP611BK / SP611SS

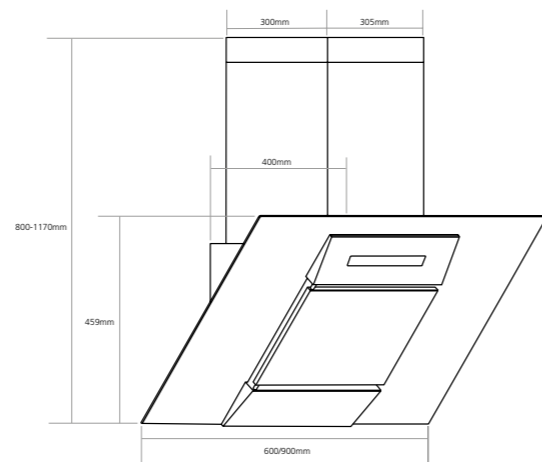

LUC600

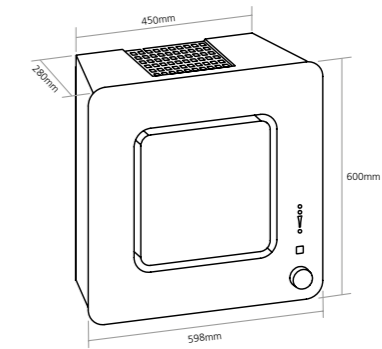
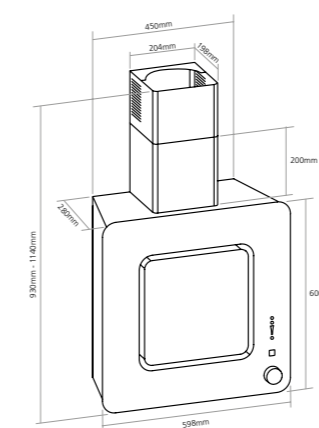

650mm space for electric hobs and 760mm space for gas hobs required from worktop to the mesh filter behind the centre glass panel. From the lowest point of the hood the distance required is 450mm for electric hobs and 550mm for gas hobs.

WALL CHIMNEY HOODS

CGC910BK / CGC910SS / CGC710BK / CGC710SS

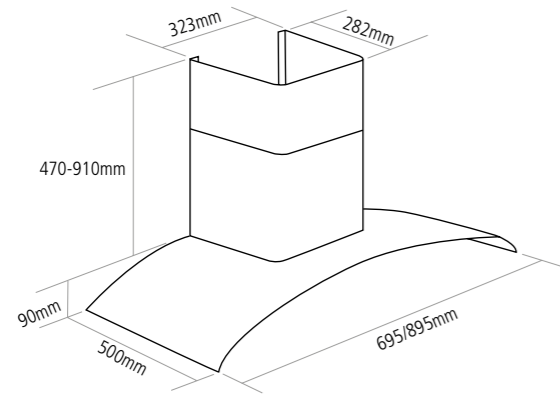

CGC610BK / CGC610SS

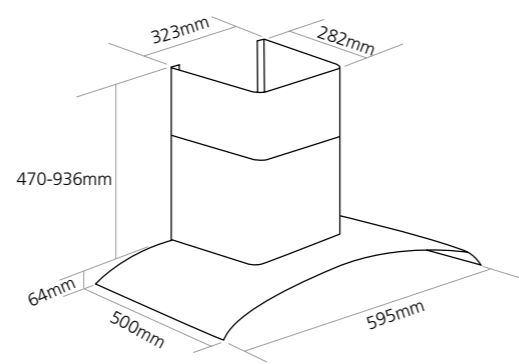

BXC911 / BXC611

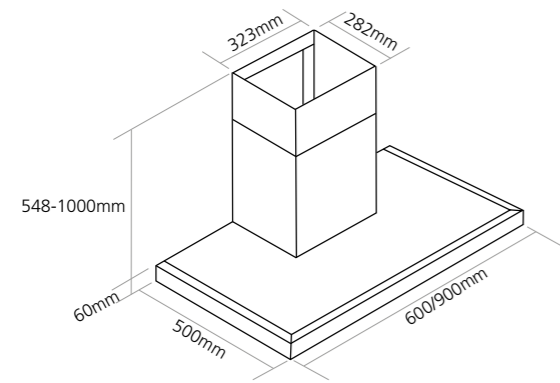

CCH100 / CCH900BK / CCH900SS
CCH700 / CCH600BK / CCH600SS

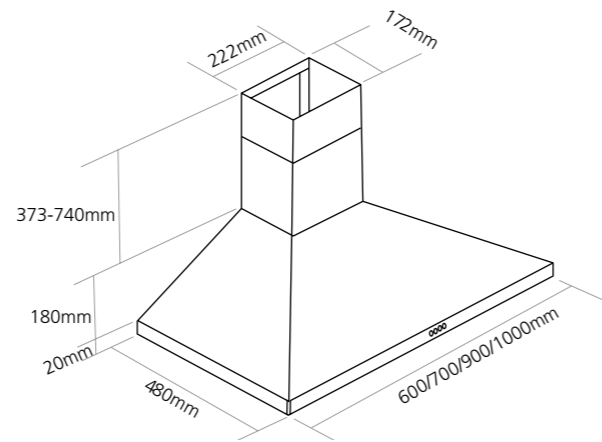

INTEGRATED HOOD

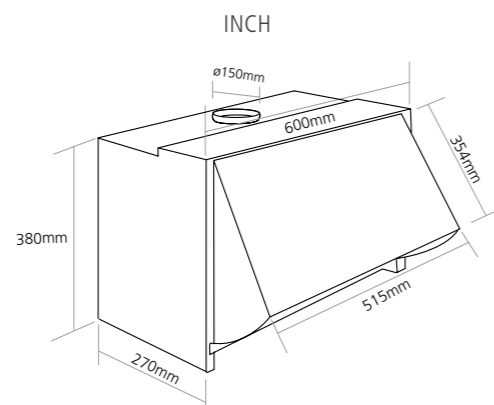

BUILT UNDER HOODS/CONVENTIONAL HOODS

TBU850

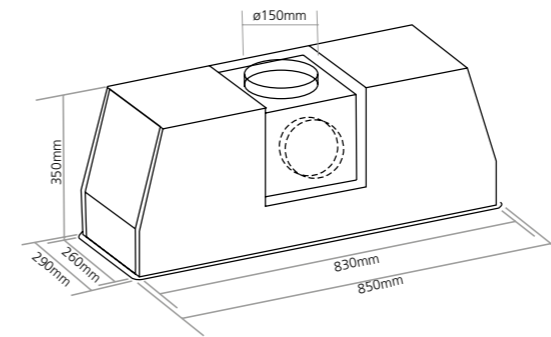

ST853

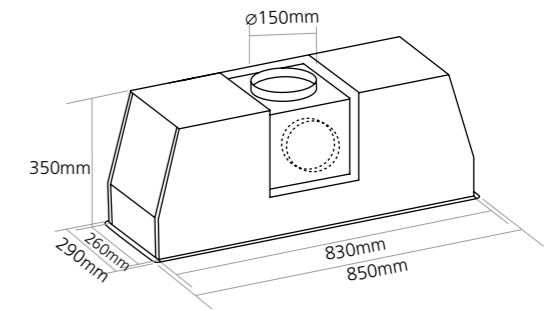

ST523

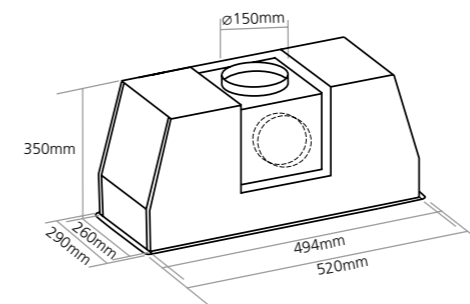

BU521

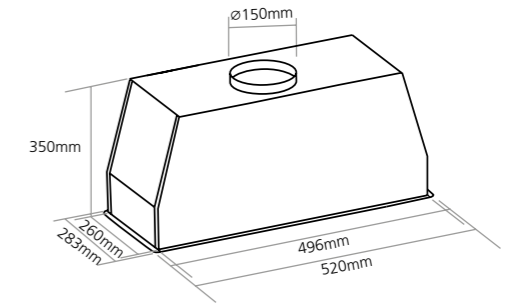

TSCH600

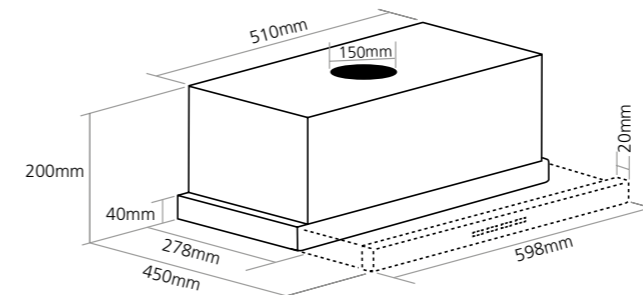

FSCHSS7

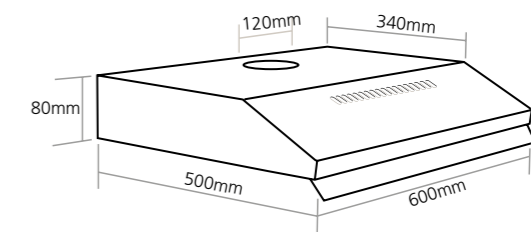

BUCH

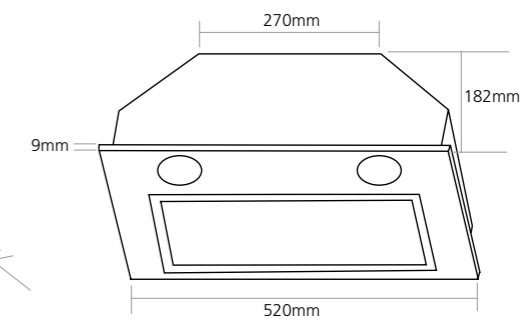
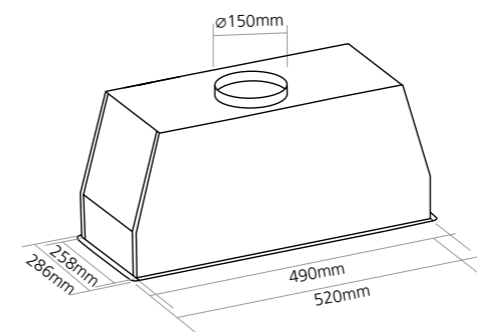



PROFESSIONAL REFRIGERATION

CAFF60 FREESTANDING

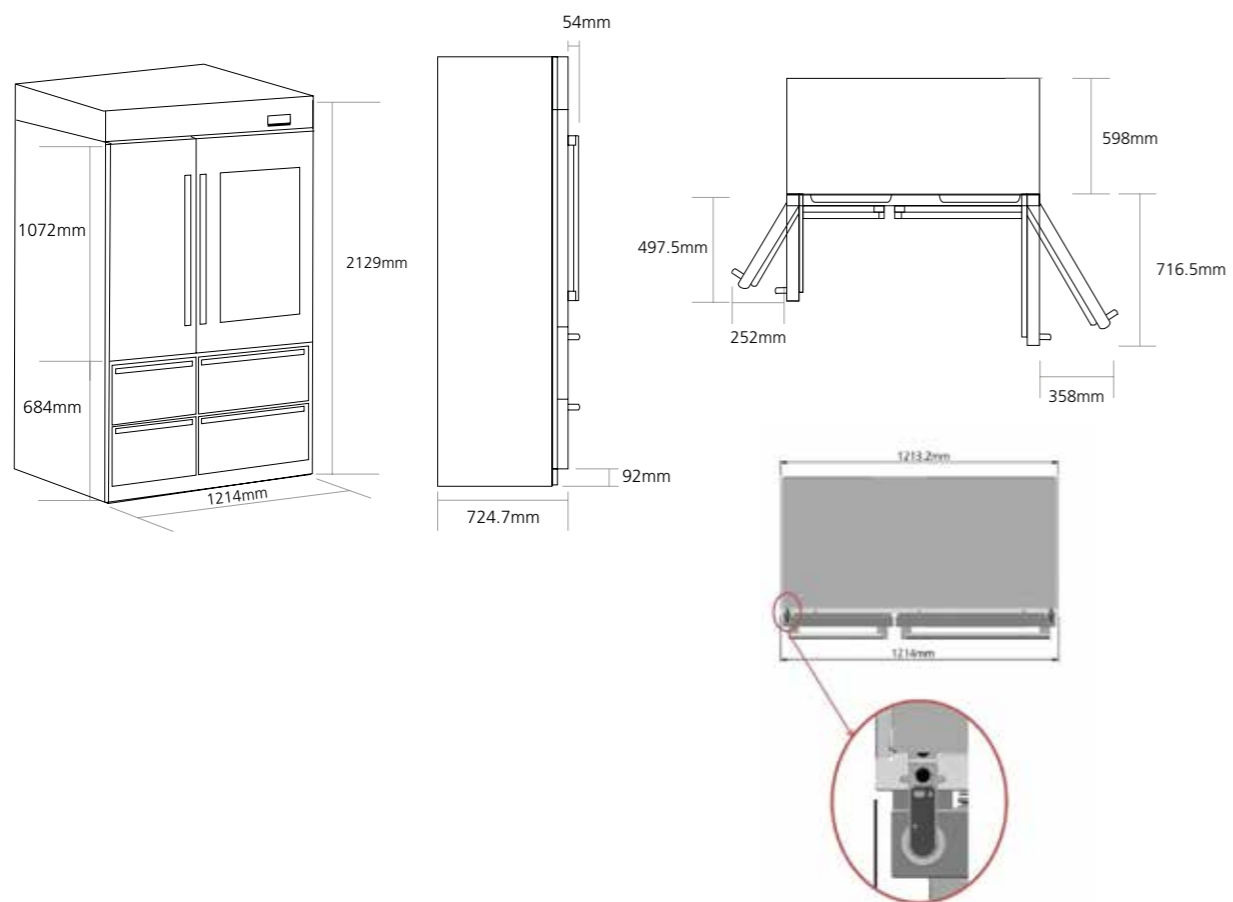

CAFF60 BUILT-IN

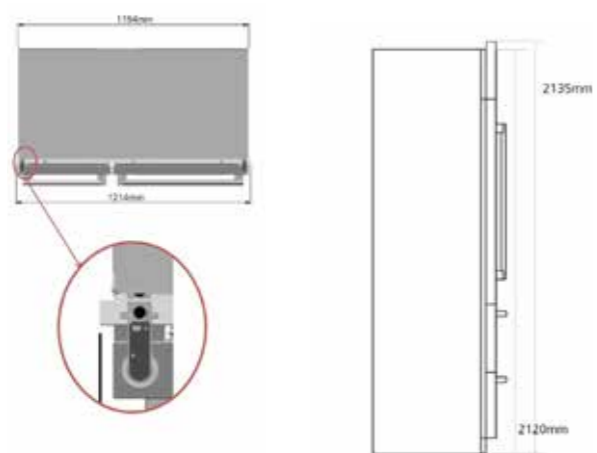

NOTE: refer to the installation instructions for the full details

FRENCH DOOR FRIDGE FREEZER

CAFF41

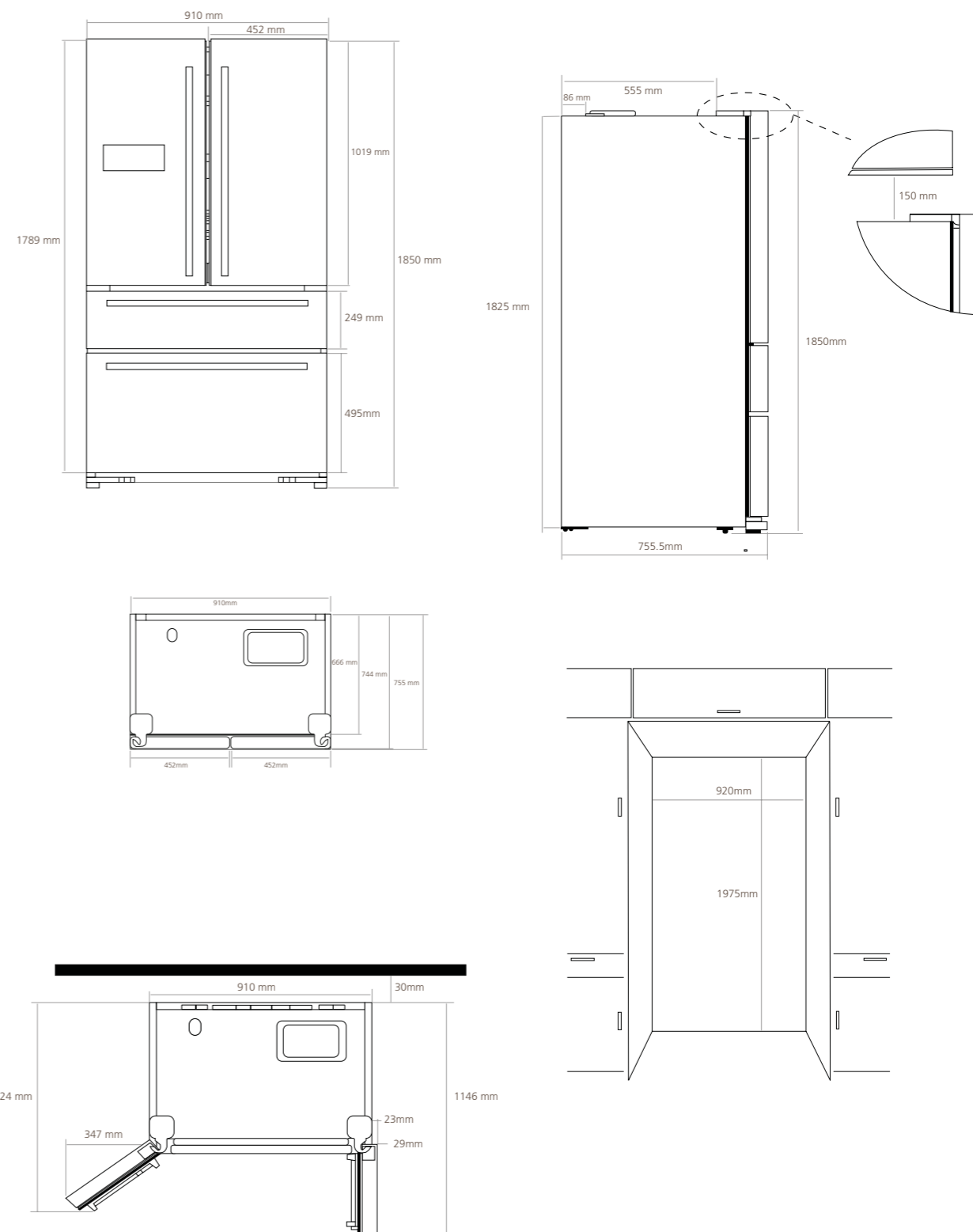



SIDE-BY-SIDE FRIDGE FREEZERS

CAFF27

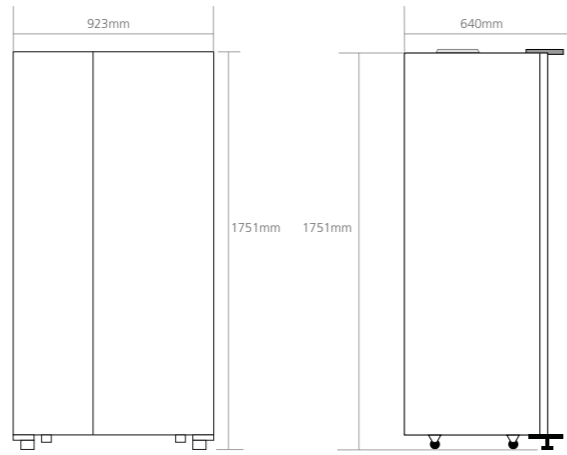

CAFF23

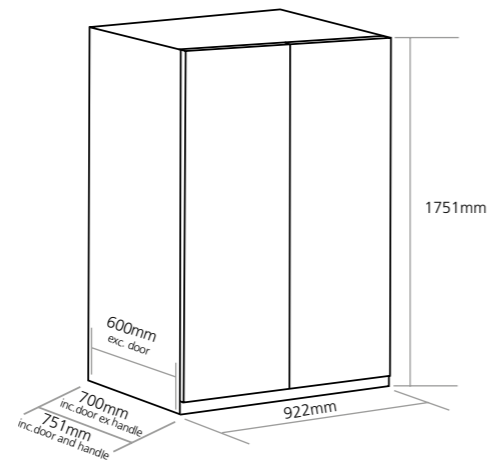

CAFF207SS / CAFF207BK

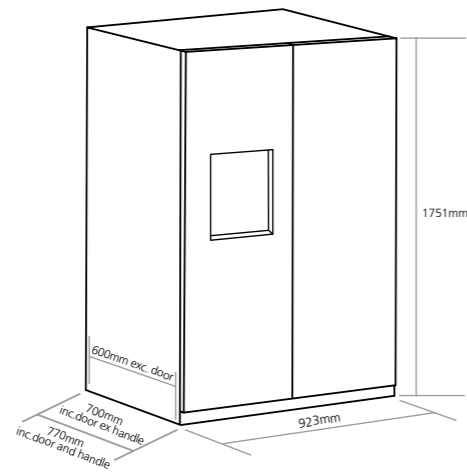

FREESTANDING REFRIGERATION

RFF730

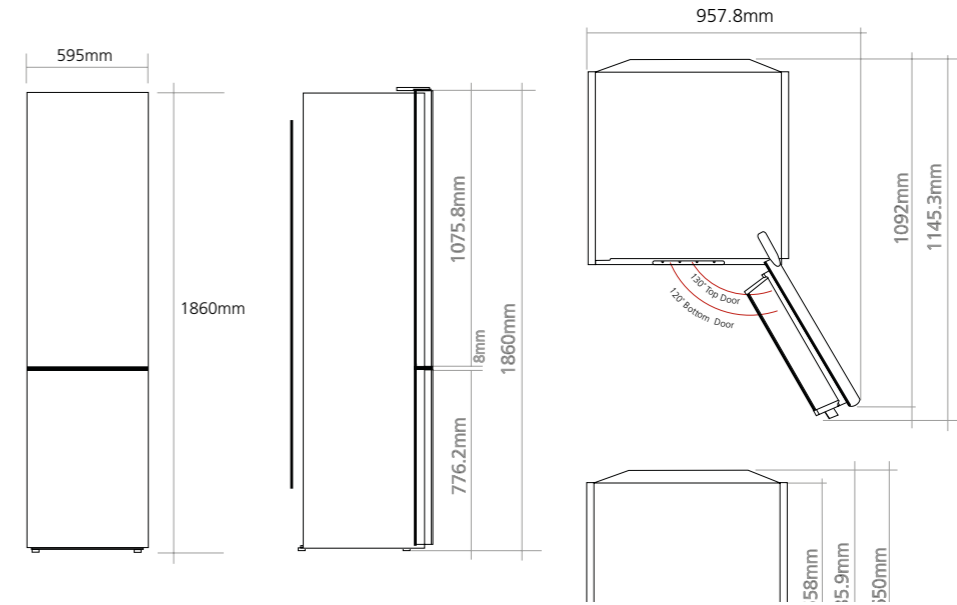

IN-COLUMN INTEGRATED REFRIGERATION

Ri737 / Ri735

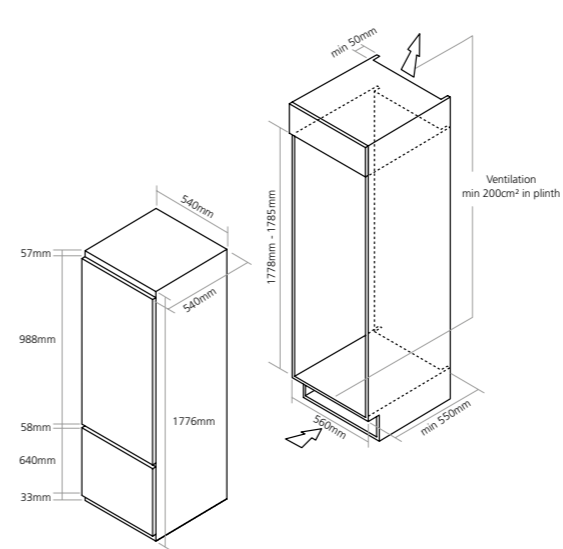

Ri558 / Ri556

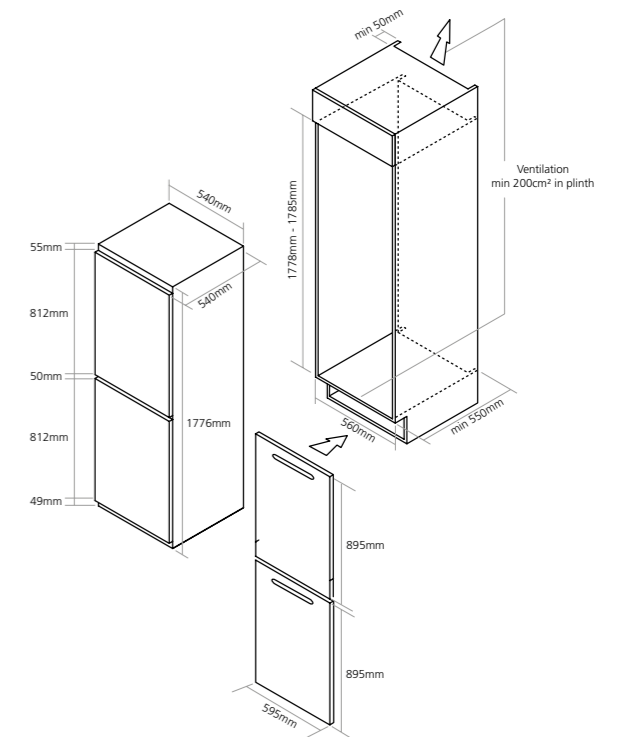

IN-COLUMN INTEGRATED REFRIGERATION

RiL1795 / RiF1795

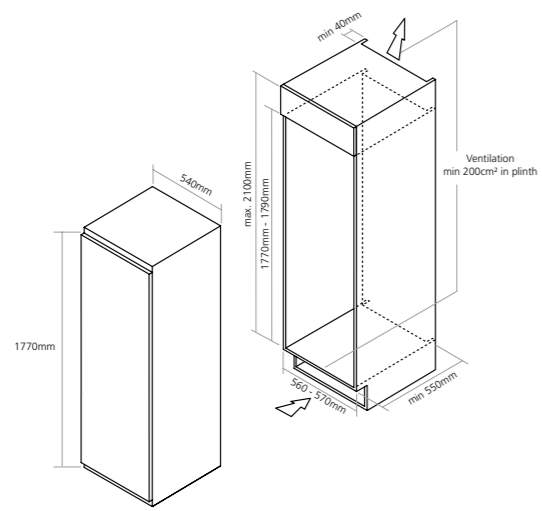

RiL891 / RiF89

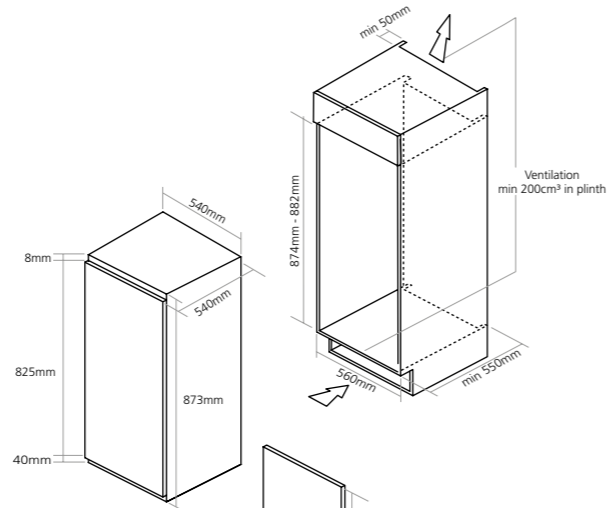

RiL124 / RiF123

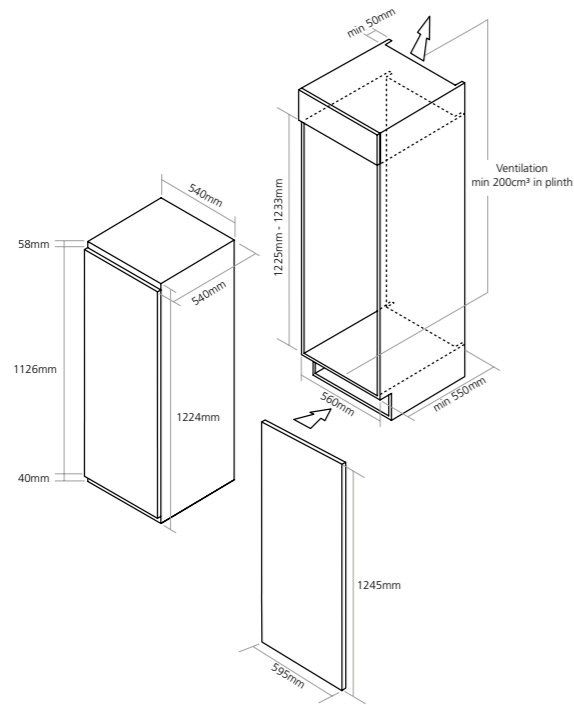

BUILT-UNDER INTEGRATED REFRIGERATION

RBL4 / RBF4 / RBR6

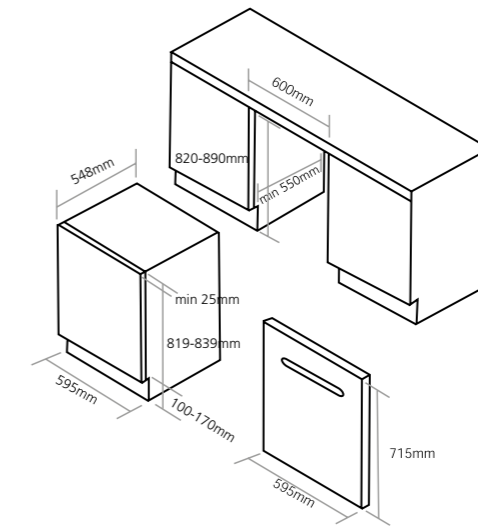

UNDERCOUNTER WINE CABINETS

Wi6233 / Wi6232

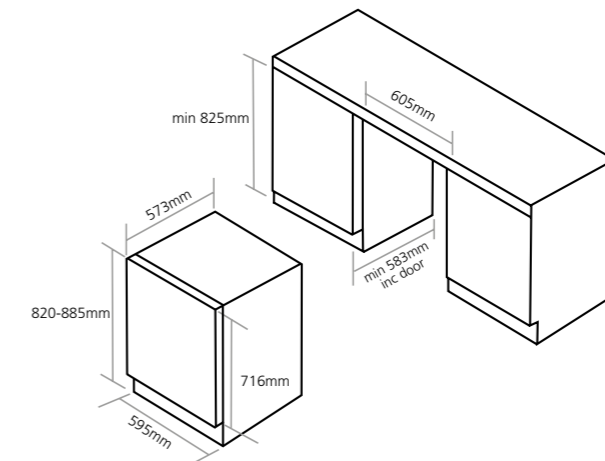

Wi6134 / Wi6133 / Wi6132WH / Wi6141 / Wi6140

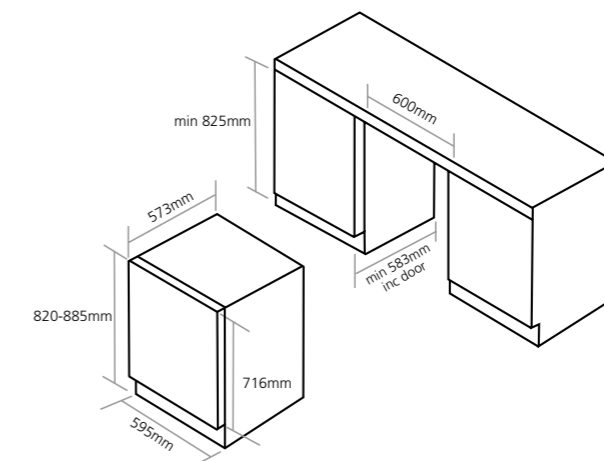

UNDERCOUNTER WINE CABINETS

Wi3124 / Wi3123 / Wi3122WH

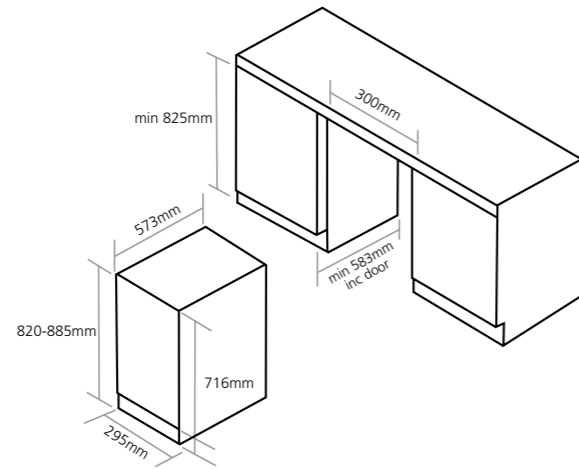

Wi154

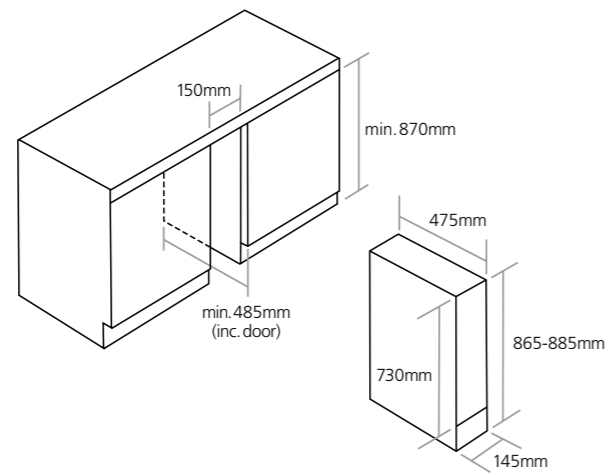

Wi155

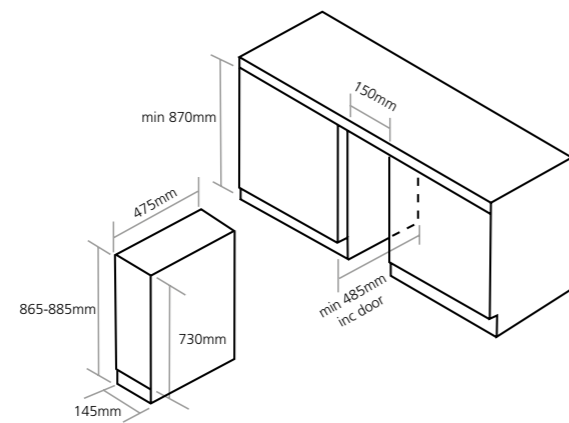

IN-COLUMN WINE CABINETS

WC179 / WC1795

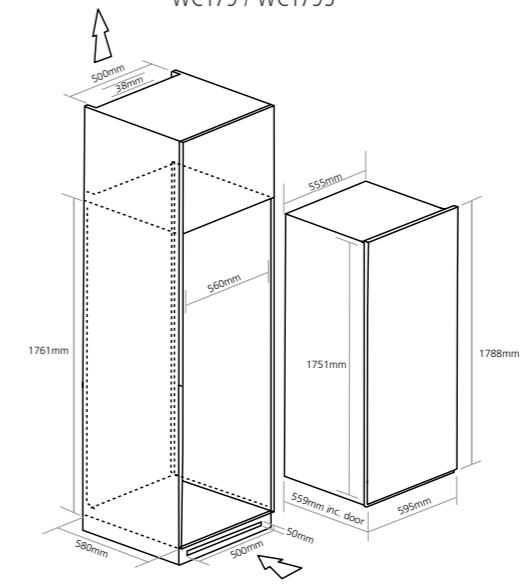

WC6520 / WC6510 / WC6500

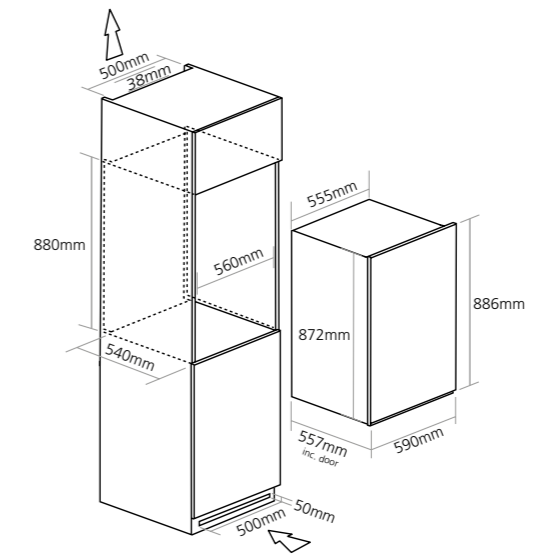

WC6410 / WC6400

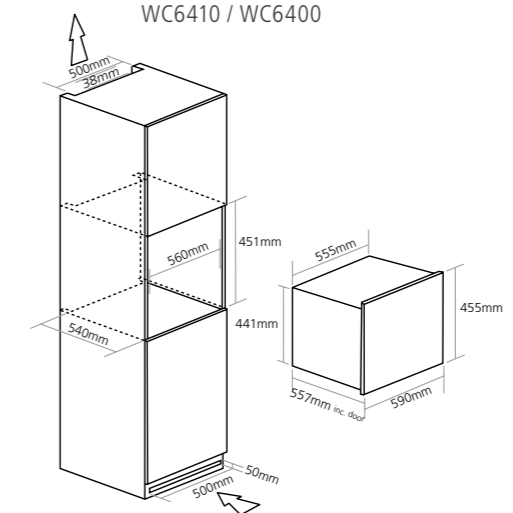



FREESTANDING WINE CABINETS

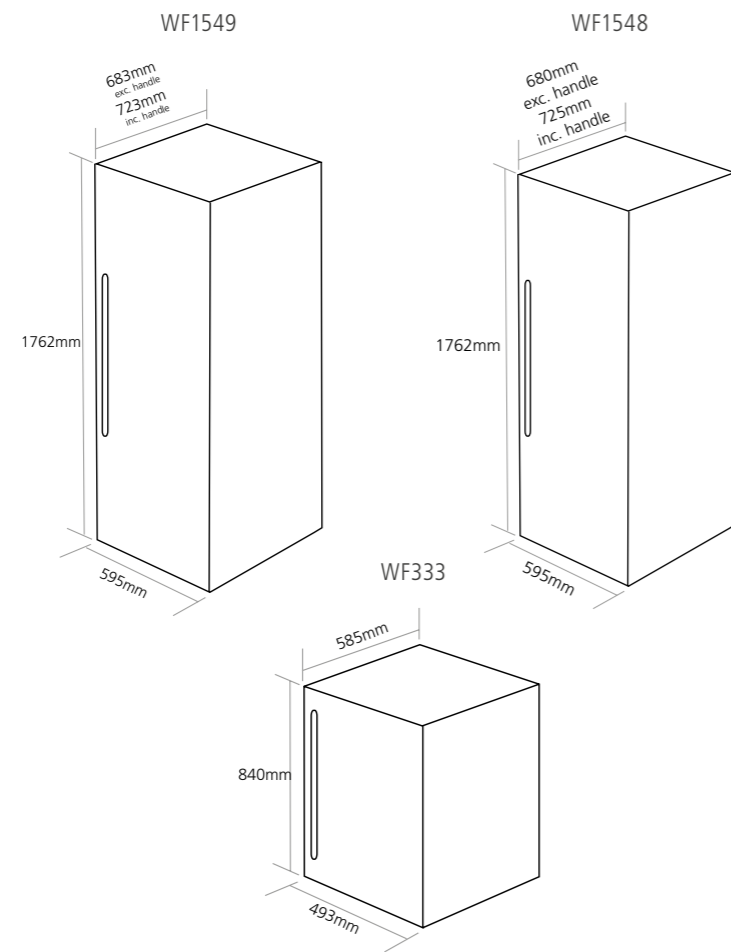

Ventilation requirements - Please allow an 127mm gap around the whole appliance when installed next to a wall, unit or in an alcove

FULLY INTEGRATED DISHWASHERS

Di651 / Di627 / Di631

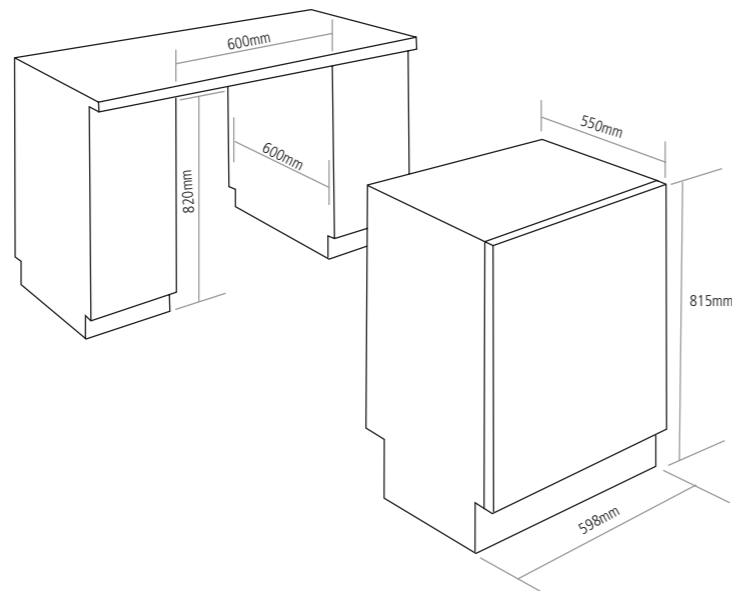

FULLY INTEGRATED DISHWASHERS

Di491 / Di481

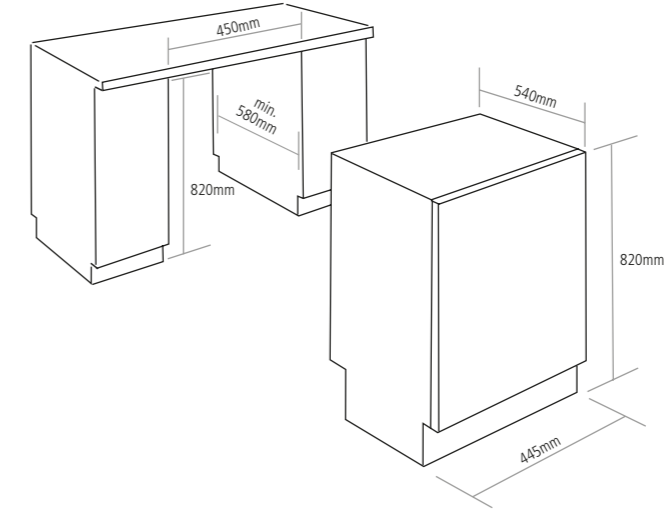

LAUNDRY

WMi3000 / WMi3005

WDi2203

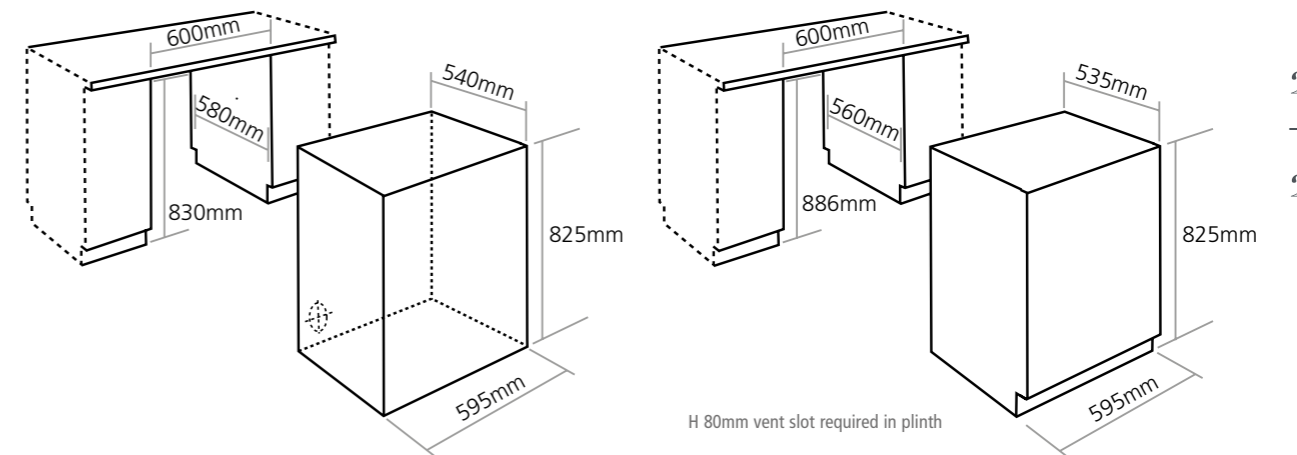

H 80mm vent slot required in plinth

TUMBLE DRYERS

TDi111 / TDi101

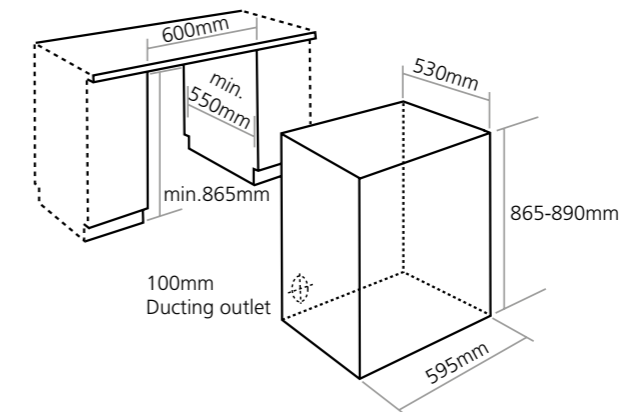



PERFORMANCE GUARANTEED



Here at Cadle, performance and reliability are the most important features considered when designing and manufacturing our products. With that in mind, we have developed Cadle Care, an after-care solution comprising of three tiers to give you that extra peace of mind.

See page 268 for more extended guarantee information.



FREE 2 YEAR GUARANTEE

Across all Cadle appliances we offer a free 2 year guarantee on parts and labour. When selecting the components to design your perfect kitchen it is important you have the right assurance without spending an extra penny. All you need to do is visit our website or call us on 0330 123 0998 to register your free 2 year guarantee.



5 YEAR EXTENDED COVER

Why not extend your cover to 5 years? Cadle Care 5 years parts and labour cover means for a one off payment or a monthly fee you can protect your appliance for a total of 5 years [including your free 2 year guarantee] on all parts and labour for any of your Cadle appliances. Please visit our website for further details or see page 294.



OUT OF GUARANTEE

If you choose not to opt for a 5 year extended warranty, don't worry. Here at Cadle we offer out of guarantee cover. So, if you are not covered under our extended warranty, for a fixed fee, we can still arrange a service call [including parts and labour] or a replacement product up to 6 years after the purchase date. Terms and conditions apply.

To register your free 2 year guarantee or discuss an extended warranty, call 0330 123 0998 or visit cadle.co.uk/guarantee

Lines are open 9am - 5pm Monday to Friday [excluding bank holidays].
Calls may be recorded and monitored for quality and training purposes.
Full Terms and Conditions can be found at www.cadle.co.uk.



CAPLE CARE



All Caple appliances come with a 2 year parts and labour guarantee. You can extend this to provide a full **5 years** parts and labour warranty.

THE BENEFITS OF TAKING OUT AN EXTENDED WARRANTY

The Caple protection plan has been carefully put together so customers who take out the extended cover benefit from:

5

Up to 5 years parts and labour warranty against breakdown



A nationwide network of Caple approved engineers to undertake repairs in the home

£

Spread the cost over 10 months with our monthly payment plan visit www.worldpay.com for full T&Cs



A replacement appliance should the repair of the original be uneconomic or impossible



Access to the Caple UK based contact centre

To register your free 2 year guarantee or discuss an extended warranty, call

0330 123 0998

Calls are charged at the local rate- please check with your provider for actual charges.

Register my appliance

TO REGISTER YOUR WINE CABINET WITH A FREE 2 YEAR GUARANTEE VISIT CAPLE.CO.UK Subject to terms and conditions



Issue: CA0218

Every effort has been made to reproduce colours and materials accurately, however due to the photography and print processes, colour variations may occur.

Due to our continued product development policy, we reserve the right to modify product specifications and/or dimensions without notice.

Please contact your retailer, call Caple direct on 0117 938 1900, email info@caple.co.uk, or visit our website at www.caple.co.uk for further product information.

E & O E

See more online at
caple.co.uk or visit
our showroom



Fourth Way
Avonmouth
Bristol
BS11 8DW

t: 0117 938 1900
f: 0800 373 163
e: sales@caple.co.uk
caple.co.uk

www.facebook.com/CapleUK
www.twitter.com/caple
www.instagram.com/capleuk



Issue: CA0218

